



CHIEF INDUSTRIES, INC.  
AGRI/INDUSTRIAL DIVISION

**#05 – #16 30° V-RIB ROOF  
INSTALLATION MANUAL**

## Manual Revisions

*Date:*

*Revision Made*

#349024

05-12-09

Changed temperature cable supports

## **CHIEF INDUSTRIES, INC.**

AGRI/INDUSTRIAL DIVISION

### **STANDARD LIMITED GRAIN BIN WARRANTY**

#### **1. WHAT IS COVERED BY THIS STANDARD LIMITED WARRANTY**

If you are the original retail purchaser of Chief Manufactured Grain Bins, which includes Bulk Feed Bins and Hopper Tanks, Chief Industries, Inc., expressly warrants to you that the components manufactured by Chief Industries, Inc., were, on the date of delivery to you, free from defects in the composition of material, Chief workmanship, and design.

#### **2. DURATION OF THIS STANDARD LIMITED WARRANTY AND NOTICE REQUIREMENTS**

This Standard Limited Warranty is applicable under normal use and service to defects which become evident within a period of five (5) years from date of delivery of your Chief Grain Bin to you and which are reported in writing to Chief Industries within 30 days of discovery of the defect. In any event, Chief's obligations under this Standard Limited Warranty shall expire sixty-one (61) months from the invoice date.

In order to obtain warranty service, simply contact Chief Industries in writing with the following information: (1) Your name; (2) Location of the product; (3) Dealer name; (4) Description of problem; (5) Any pertinent information; (6) Date of purchase. No claim will be processed until all of this information has been received in writing by Chief Industries. For warranty service, contact Chief Industries, Inc., Agri/Industrial Division, Customer Service Department, P. O. Box 848, Kearney, NE 68848.

#### **3. CHIEF'S OBLIGATIONS**

By purchasing your Chief Grain Bin subject to this Standard Limited Warranty, you and Chief Industries expressly agree to an allocation of the risks of product failure between you and Chief Industries. This allocation is recognized by both parties and is reflected in the price of the Chief Grain Bin.

#### **4. REMEDIES AVAILABLE FROM CHIEF**

If a defect in your Chief Grain Bin is covered by this standard limited warranty, Chief Industries will supply replacement parts F.O.B. Chief Industries, Kearney, Nebraska. In addition, during the first year of the warranty, Chief Industries will supply labor necessary to make repairs in your Chief Grain Bin made necessary by such defect or faults. Chief Industries will request at least two competitive bids for labor, as shall in the judgement of Chief Industries be the most appropriate remedy for the failure covered by this warranty. Of course, Chief Industries reserves the right to reject all such bids and to obtain additional bids. Upon acceptance of a bid by Chief Industries, Chief Industries will authorize the necessary repair.

#### **5. REMEDIES NOT AVAILABLE FROM CHIEF**

The obligations stated in the preceding paragraph are the SOLE AND EXCLUSIVE REMEDIES available from Chief Industries in the event of problems with your Chief Grain Bin. Chief Industries will not be liable for the costs of dismantling defective parts or installing replacement parts, including labor costs, after the first year, and Chief Industries will not be liable for any special, incidental or consequential damages based upon breach of warranty, breach of contract, negligence, strict tort, or any other legal theory.

#### **6. WHAT IS NOT COVERED BY THIS STANDARD LIMITED WARRANTY**

This Standard Limited Warranty does not cover:

- (a) Chief manufactured product not sold as part of the grain bin.
- (b) Products, components, equipment, accessories, or parts manufactured by someone other than Chief Industries.
- (c) Accessories, Temporary Grain Storage Bins or Bins designed for storage of products other than whole grain storage.
- (d) Damage or loss during shipment of the Chief Grain Bins.
- (e) Damage or loss caused by the acts or omissions of the erector or his agents.

**6. WHAT IS NOT COVERED BY THIS STANDARD LIMITED WARRANTY (continued)**

- (f) Damage or loss caused, in whole or in part, by inadequate or improper site selection, inadequate or improper site preparation, inadequate or improper foundation, or any other failure to provide a suitable erection or installation environment for or a suitable erection or installation of the Chief Grain Bin, or of any product, component, equipment, accessories, parts used in conjunction with the Chief Grain Bin.
- (g) Damage or loss caused, in whole or in part, by use of the Chief Grain Bin for purposes other than those for which it was designed.
- (h) Damage or loss caused, in whole or in part, by unauthorized attachments, modifications, or alterations of the Chief Grain Bin.
- (i) Damage or loss caused, in whole or in part, by improper or inadequate maintenance, misuse, or abuse of the Chief Grain Bin.

**7. NO OTHER WARRANTIES**

(1) Complete and Exclusive Agreement: THIS AGREEMENT IS THE COMPLETE AND EXCLUSIVE AGREEMENT BETWEEN YOU AND CHIEF INDUSTRIES, INC., CONCERNING THE ALLOCATION OF THE RISKS OF DAMAGE OR LOSS ARISING FROM MANUFACTURED COMPONENT FAILURE. It supersedes all prior agreements, whether written or oral, and all other communications between you and Chief concerning the allocation of those risks. No employee of Chief Industries, Inc., or any other person, including Authorized Dealers and any other person authorized to sell Chief Grain Bins, has any authority to make any representations, promises, or warranties in addition to those contained herein.

(2) THIS STANDARD LIMITED WARRANTY IS IN LIEU OF ALL OTHER WARRANTIES, EXPRESSED OR IMPLIED, INCLUDING WARRANTIES OF MERCHANTABILITY AND FITNESS FOR A PARTICULAR PURPOSE.

**8. ALLOCATION OF RISKS**

THIS AGREEMENT ALLOCATES THE RISKS OF DAMAGE OR LOSS ARISING FROM PRODUCT FAILURE BETWEEN CHIEF INDUSTRIES, INC., AND PURCHASER. THIS ALLOCATION IS RECOGNIZED BY BOTH PARTIES AND WAS REFLECTED IN THE PURCHASE PRICE OF THE GOODS.

# Section 1 – Grain Bin Specifications

## 1. GENERAL DESIGN INFORMATION

- a) All Chief Industries grain bins are designed for storage and handling of 49.5 PCF (793 kg/m<sup>3</sup>) free flowing grain (52.5 PCF (841 kg/m<sup>3</sup>) compacted grain @ 6%). Grain fill level shall not exceed 1" (25.4 mm) down from eave.
- b) Storage of products other than grain (products heavier than 49.5 PCF (793 kg/m<sup>3</sup>), products having unusual flow characteristics or unusual corrosive properties) must be approved by Chief Industries' Engineering Department prior to quoting. Storage of soybean meal or meat scraps or other non-flowing products in standard tanks will void the warranty.
- c) Each individual sidewall ring has been designed to accommodate the vertical and horizontal wall loads imposed by the stored grain. Sheeting gauge and design strength for each ring is individually analyzed for all bin sizes. Also, stiffener gauges and design strengths are individually determined for each bin's full sidewall height range. All steel materials are purchased in accordance with the applicable ASTM Standard.
- d) All bolted connections are designed using high strength bolts which meet the specifications of the applicable ASTM or SAE Standards.
- e) All bins must be filled uniformly at the center and unloaded through the center discharge only, until grain no longer flows by gravity. Bins filled or emptied off-center will void the warranty; except approved sidedraw systems. (Refer to Section 5c for Sidedraw Usage)
- f) All Galvanized Steel used for storage and drying bins conform to ASTM specification A653 and the Galvanized coating to A924, TYPE G-115; 1.15 oz/ft.<sup>2</sup> (Z350; 350 gm/m<sup>2</sup>) total for both sides as follows:

22 Ga. Thickness & lighter = CS TYPE A; 33ksi min yield (grade 230)

18 & 20 Ga Thickness = SS Grade 40, Class I; 40ksi min yield (grade 275)

17 Ga. Thickness & heavier = SS Grade 55, Class I; 55ksi min yield (grade 340)

(Please note: SS = Structural Steel)

## 2. ROOF DESIGN

All roofs are certified to withstand normally anticipated environmental and service conditions.

### **IMPORTANT:**

**Roof peak loads in excess of specified rating can cause structural roof damage and will void all bin warranties.**

#### **A) J-Rib Roof Design**

1) The CB5 thru CB11 grain bin roofs are available standard with a 30° slope. The CB9 thru CB11 bin roofs are designed to incorporate a structural bridging ring. These roofs have 4 roof panels per sidewall sheet and are certified for 90mph (145 km/hr) wind with 17 PSF (0.79 kPa) ground snow load plus roof dead load and concentrated peak load of 1000 LB (454 kg) with a 30" (762 mm) peak ring diameter.

2) The CB12 through CB34 grain bin roofs have a 30° roof slope and utilize a complete structural framing system which supports loads independent of the roof panels. The CB12 through CB16 bin roofs are certified for 90 mph (145 km/hr) wind with a 30 PSF (1.44 kPa) ground snow load plus roof dead load and a concentrated peak load of 16,000 LB (7258 kg) with a 40" (1016 mm) peak ring diameter. CB18 through CB34 bin roofs are certified for 90 mph (145 km/hr) wind with a 30 PSF (1.44 kPa) ground snow load plus roof dead load and a concentrated peak load of 25,000 LB (11338 kg) with a 72" (1829mm) peak ring diameter.

3) **WORKING RING:** Standard on all #5 thru #34 bins. Constructed of 1-1/2" (38mm) pipe and provides a continuous ring around the center and is attached with heavy gauge brackets located on top of roof ribs, close to roof cap.

#### **B) V-Rib Roof Design**

1) All CBU & CBUE Storage and Drying Bins are designed for 90 mph (145 km/hr) with a 30 PSF (1.44 kPa) (ground snow load plus roof deadload). Additional concentrated load may be applied at the peak of the bin up to 3,500 lbs. (1588kg) for #5 thru #7 and 6,000 lbs.(2722 kg) for #8 thru #12 bins with a 30" (762 mm) peak ring and up to 8,500 lbs.(2949 kg) for #14 and #16 bins with a 40" (1.0 m) peak ring.

2) The roof slope of CBU & CBUE Storage and Drying Bins is 30° for all #5 through #16 bins. Roof panels are 22 gauge and have four roof panels per sidewall sheet. One piece roof panels are standard for all roofs and feature 2-1/2"(64mm) deep ribs for #5 through #12 roofs and 4" (102 mm) deep ribs for #14 and #16 roofs. An optional eave sealer is available if desired.

3) Roof Rib Fasteners are 5/16" (8 mm) diameter JS500 zinc plated hex head bin bolts facilitates quicker assembly of the bin roof and a positive, structural and weather resistant rib to rib connection.

4) Heavy gauge formed galvanized eave clips bolt directly to roof panel and wall sheet. Clips are adjustable with slotted holes to raise or lower roof as desired. "Hurricane Clips" are standard on all bins.

5) **WORKING RINGS:** Standard on all #5 thru #16 bins. Constructed of 1-1/2" (38mm) pipe and provides a continuous ring around the center and is attached with heavy gauge brackets located on top of roof ribs, close to roof cap.

6) **ROOF BRIDGING RINGS:** One outside roof bridging ring is standard on all #10 thru #12 bins and optional for #7 thru #9 bins. Two roof bridging rings are standard for #14 and #16 bins. Rings are fabricated from heavy gauge 1-1/2" (38mm) diameter tube and threaded connectors expand to position the ring in place.

### 3. GRAIN BIN USAGE

#### a) CBU & CBUE UNSTIFFENED BIN SERIES

The Unstiffened bins are designed and intended for storage and drying of common small grains. This includes all models except for the 8 thru 10 rings tall bins which are used for storage (Not Drying) only. All unstiffened bins up through 7 rings tall will accommodate a stirring device consisting of no more than three down augers.

#### b) CB STIFFENED TO EAVE BIN SERIES

The CB Stiffened to Eave Bins may be used for all common drying applications, these bins are available in sizes CB #5 thru #16. If stirring devices consisting of more than six down augers are to be used, contact Chief Industries, Inc., for recommendations. This bin must be used when Stirway II's, Recirculating devices, and stirring devices with four or more down augers are to be installed.

Note: See detail on using Stirring Devices

### 4. THE GENERAL CONTRACTOR'S RESPONSIBILITIES

It is the responsibility of the General Contractor to insure that the complete bin system (bin, foundation, grain transport equipment, aeration equipment, and other accessory equipment) is constructed in a quality workmanship manner and that all equipment is installed per the respective manufacturer's instructions.

In addition, the General Contractor is responsible for the fitness of use of any system which he constructs. All accessory equipment incorporated into the system should be approved for the intended use of each respective equipment manufacturer.

#### a) Field Modifications and Erection Defects

Chief Industries, Inc., assumes no responsibility for field modifications or erection defects which create structural or storage quality problems. If any field modifications are necessary which are not specifically covered by the contents of our erection manual, contact Chief Industries, Inc., for approval of the field modifications. Any unauthorized modification or erection defect which affects the structural integrity of the Chief bin will be cause for immediate nullification of the Chief Grain Bin Warranty.

#### b) Concrete Information for Design and Construction

The suggested foundation designs shown in the bin erection manuals are based on the allowable soil bearing capacity of the undisturbed soil and should be checked by a licensed engineering firm. Using soil borings to determine the allowable soil bearing capacity, a professional engineer will need to be engaged by the contractor to design the foundation and floor slab accordingly. All suggested foundation designs must be approved by a licensed engineer in order to meet local governing building codes and local soil and weather conditions. Wall loads and floor pressure for standard Chief grain bins are available from Chief Industries, Inc., upon request.

**IMPORTANT: THE FINISHED FLOOR SURFACE MUST BE LEVEL AT THE BIN WALL LOCATION. LOW SPOTS IN PERIMETER WALL ELEVATION WITHOUT ADEQUATE SHIMMING CAN CAUSE STRUCTURAL DAMAGE TO THE BIN SIDEWALL. FAULTY CONCRETE WORK OR SHIM OMISSION WILL NULLIFY THE BIN'S WARRANTY.**

The suggested concrete foundation designs must not be used in conjunction with unload and aeration tunnels. Concrete and reinforcing bar requirements must be determined by a certified professional engineer. The design must consider soil bearing capacity, soil consolidation, footing requirements, tunnel requirements and the interaction of all foundation components under loaded condition. Non-uniform settlement of the foundation can cause severe structural damage to bin and foundation. An improperly designed or constructed foundation will void all aspects of the bin warranty. It is the responsibility of the General Contractor to insure that an adequate foundation is provided for the bin.

## 5. ACCESSORY EQUIPMENT

All accessory equipment should be installed and maintained in accordance with each individual suppliers installation and operation instructions. However, if any sidewall penetrations or other modifications to Chief Industries, Inc., standard bin design are required, refer to bin erection manual or contact Chief Industries, Inc., for special recommendations. Do Not Modify Bin Design Without Chief Approval. It is the responsibility of the General Contractor to insure that all equipment is properly installed and that the equipment is compatible with the intended use. A qualified electrician should be contracted to complete all electrical wiring and servicing.

Chief Industries, Inc., provides no warranty concerning parts, accessories or equipment not manufactured by Chief Industries, Inc.

### a) Roof Peak Service Loads

When determining the service loads on the roof peak, the weight of all accessory equipment suspended or supported by the peak should be considered. The weights should be calculated using the equipment dead load plus the operating load. For example, the weight of an overhead conveyor should include the catwalk, conveyor head assembly, motors, drives, downspouts, discharges and weight of grain when in operation. If conveyor and catwalk design is such that snow build up is likely during winter months, snow load must be added in the peak load calculation. If a temperature cable is suspended from peak add 1000 lbs. (452 kg.) per 40 foot (12.2 m) of cable length to the peak's service load. Interpolate value for intermediate cable length; i.e., 60 foot (18.3 m) cable would exert 1500 lbs. (680 kg), of load.

**Do not allow excessive snow and ice to accumulate on any portion of the roof.**

### b) Bin Loading Equipment

Center filling through the peak opening is required for all bins. Off center loading will create unequal pressures on the bin wall and result in structural damage. If downspouting is to be used, it is recommended that a dead head or cushion box be used to promote uniform filling. Also, the use of spreaders or splash plates are recommended for distributing the grain fines, promoting uniform air flow through grain and leveling the grain peak.

Standard Commercial Bins (CB18 (55'8") and larger) can be loaded at a rate below 40,000 bushels per hour. If bin is to be loaded at a rate of 40,000 bushel an hour or greater, or is smaller than a CB18 (55'8"), contact Chief Industries, Inc. for upgrade recommendations.

**IMPORTANT: FILL CONVEYORS AND THE CATWALK MUST NOT BE SUPPORTED BY STANDARD GRAIN BIN WALL. USE INDEPENDENT SUPPORT TOWERS TO SUPPORT OVERHEAD CONVEYORS OR CB STIFFENED BINS WITH UPGRADED STIFFENERS TO SUPPORT THIS TYPE OF LOAD.**

### c) Bin Unloading Equipment

All bins must be unloaded through center discharge. If intermediate wells are installed in the floor, they must not be opened until all gravity flow through the center well has ceased. Therefore, center and intermediate wells must have separate control rods. The center well's sweep auger pivot should be centered in the bin to insure unobstructed sweep rotation. If unloading auger exits through bin wall, thoroughly seal around auger tube to prevent moisture and airflow leakage. Reinforcing of sidewall sheets will be necessary if auger exits through the bin wall at a point exposed to direct grain pressure. Contact Chief Industries, Inc., for reinforcing recommendations.



Standard Commercial Bins (CB18 (55'8") and larger) can be unloaded at a rate below 20,000 bushels per hour. If bin is to be unloaded at a rate of 20,000 bushel an hour or greater, or is smaller than a CB18 (55'8"), contact Chief Industries, Inc. for upgrade recommendations.

Sidedraw baffle systems may be installed in the bin sizes specified in Chief catalog. Also, Only Chief approved sidedraw units can be installed in a Chief grain bin.

**IMPORTANT: ANY SIDEDRAW UNIT IMPROPERLY INSTALLED IN A CHIEF BIN WITHOUT CHIEF INDUSTRIES' APPROVAL, OR SIDEDRAW UNITS MANUFACTURED BY OTHER THAN CHIEF INDUSTRIES, INC., COULD RESULT IN STRUCTURAL DAMAGE TO THE BIN AND WILL VOID THE BIN WARRANTY.**

**Note:** If multiple sidedraws are being used, only 1 sidedraw may be used at a time. It is required that the bin is coned from the center discharge to level the grain in the tank before refilling after the sidedraw has been used. Prior to prolonged storage, grain should be coned or taken to a level condition.

#### d) Roof Vents

**IMPORTANT: HIGH UNLOADING RATES CAN CREATE A VACUUM INSIDE BIN. IF UNLOADING RATES EXCEED 5000 BUSHELS (125 MT) PER HOUR, A MINIMUM OF ONE FREE INTAKE VENT (GOOSE NECK VENT RECOMMENDED) MUST BE INSTALLED. ONE UNOBSTRUCTED STANDARD CALDWELL BIN VENT WILL PROVIDE ADEQUATE VENTING UP TO AN UNLOADING RATE OF 80,000 BPH (2000 MT/HR). IF SUBSTANTIALLY HIGHER RATES ARE NEEDED, PLEASE CONTACT CHIEF INDUSTRIES FOR A RECOMMENDED VENT REQUIREMENT. (Note: refer to maximum loading and unloading rates allowed in the bin).**

#### e) Temperature Cables

Temperature cables can be installed in all standard Chief bins; the number and location of temperature cables for each bin size are listed in the temperature cable installation section of the erection manual.

Temperature cable support kits supplied by Chief Industries, Inc., are available and must be used whenever temperature cables are installed. Be sure to allow adequate clearance for sweep augers or other internal equipment. Follow temperature cable manufacturer's recommendations for shortening temperature cables if necessary, provide adequate sealant where temperature cable lead wire exits the bins.

**IMPORTANT: SUPPORT OF TEMPERATURE CABLES BY ANY MEANS OTHER THAN CHIEF INDUSTRIES' RECOMMENDED SUPPORT KITS MAY CAUSE STRUCTURAL DAMAGE TO THE BIN ROOF AND WILL NULLIFY THE CHIEF GRAIN BIN WARRANTY.**

**IMPORTANT: All TEMPERATURE CABLES SHOULD BE SECURED TO FLOOR TO PREVENT CABLE FROM DRIFTING TOWARD BIN WALL DURING FILLING. THE USE OF LIGHT TWINE OR MONOFILAMENT LINE SECURED TO A RECESSED ANCHOR IS RECOMMENDED.**

***Note: Structured Roofs are designed for a maximum load of 2,000 lbs. per temperature cable. If this load is exceeded, this may cause structural damage to the bin roof and will nullify the Chief Grain Bin Warranty.***

#### f) Fans and Transitions

Aeration fans should be sized in accordance with Chief's specifications for the particular bin being considered.

All fans must be installed per Chief's recommendations and leveled prior to operation. A qualified electrician should be contracted to complete all electrical wiring and servicing.

The transition through the bin wall must be thoroughly sealed around the outside of the transition entrance collar to prevent airflow leakage. Use of strip caulking in combination with flashing provided by the transition manufacturer is recommended. If the transition interrupts a stiffener line, the special transition stiffener available from Chief Industries, Inc., must be installed as described in the erection manual. Also, if the transition enters through the bin's bottom sidewall sheet (full floor aeration and tube aeration), adequate reinforcing of the bottom sidewall sheet must be added. Contact Chief Industries, Inc., for recommendations. Standard drying bins do not require reinforcing of bottom sidewall sheet as long as transition enters below the false floor level.

#### g) Heaters

The heater unit must be properly matched with the fan size to be used. Heater unit and fan must be compatible, and it is recommended that both units be supplied by the same manufacturer to insure compatibility and safety. Heater unit installation and servicing should only be completed by personnel properly trained by the manufacturer of products being used. The fan and heater need to be located on the bin to assure uniform airflow to the bin. The units should be located at a 180° angular position from the outlet of the withdrawal tube.

**DANGER:** Fuel tanks, lines and all valves must be compatible with the type of fuel to be used. Failure to use certified fuel tanks, lines or valves can result in death or severe personal injury.

**DANGER:** Never use anhydrous ammonia tanks or improperly modified fuel tanks for L.P. gas storage.

**DANGER:** L.P. fuel flow control regulators must be installed as recommended by heater unit manufacturer.

**DANGER:** Natural gas flow regulators at the service entrance must be installed by natural gas supplier and must not be modified.

The drying temperature should be established based on the type of grain to be dried. Contact Chief for optimum drying temperature. Excessive heat can result in grain damage, overdrying and potential grain fires.

**CAUTION:** When drying sunflower seeds, the drying temperature should not exceed 105° Fahrenheit (41° Celcius). Higher temperatures can result in sunflower oil combustion.

#### h) Aeration Floors

Chief recommends the use of channellock floors with steel supports for full floor applications. Commercial applications, (floors loaded and unloaded more than once per year) and bins with a total grain depth of 60' (18.3 m) or greater require an 18 gauge (1.3 mm) floor. The floor layout support spacing must be followed for the particular bin being constructed. Floor supports, fan locations and auger tube should be oriented as shown in the manufacturer's floor plan to insure optimum airflow movement.

Corrugated perforated floors require a concrete block and lumber support system. Concrete block and lumber floor supports are not recommended in bins larger than the #13 or bins taller than eight rings. Airflow restrictions when using concrete block and lumber can significantly reduce the air flow efficiency.

### **i) Roof Ventilation**

Any grain bins using forced air for aeration or drying must be provided with sufficient exhaust or intake vents to prevent excessive internal pressures, either positive or negative. The vent supplier should be consulted for ventilation requirements on each project, with the specific bin size, grain type and depth, fan size and floor type taken into consideration. Chief Industries, Inc., does not recommend the use of negative aeration systems. In the event that negative aeration is to be used, the intake vent requirement should be sized for the bin in the empty condition.

**IMPORTANT: ROOF VENT MUST BE FREE OF DEBRIS OR OTHER OBSTRUCTIONS PRIOR TO OPERATION OF FANS.**

**POWER FANS SHOULD NOT BE OPERATED WHEN AMBIENT TEMPERATURE IS BELOW 35° FAHRENHEIT (2° Celsius) DUE TO POTENTIAL OF VENT ICING.**

**OBSTRUCTED OR ICED VENTS CAN SIGNIFICANTLY INCREASE INTERNAL TO EXTERNAL PRESSURE DIFFERENTIAL AND COULD RESULT IN STRUCTURAL DAMAGE TO BIN ROOF, WALL OR BOTH.**

### **j) Stirring Device**

Stirring devices can be installed in any drying bin, with the limitations discussed in Section 3. The bins storage capacity will be reduced when installing a stirring device. Drying bin storage capacities listed in the Chief catalog should be used with the additional capacity reduction for down auger drive unit clearance. Inside ladders may require short brackets for wall attachment to provide clearance for the stirring device.

**CAUTION: The grain level must not be filled above the stirring device. Grain pressure on the stirring device could cause roof or stirring device damage.**

Down augers may require shortening in order to provide minimum floor clearance of 3"-5" (76mm -127 mm) or additional clearance for sweep augers. Manufacturer's down auger shortening procedure should be followed.

### **k) Recirculators or Continuous Flow**

Recirculators can only be installed in CB bins. These devices should be installed as instructed by the manufacturer and with the following additional considerations:

- a. Consult floor manufacturer for recommended floor reinforcing measures at base of recirculator.
- b. If transfer auger exits through roof panels, provide sealant around auger tube to prevent water leakage.
- c. The weight of the transfer auger must not be supported by the roof panels. The transfer auger should be supported by the recirculator boot and an adjacent bin or independent support.

## Sidedraw Operation

***WARNING! Sidedraw rules must be followed when operating bins with sidedraw systems installed in them. Failure to do so could cause structural damage to the bin and will void the Bin Warranty.***

Sidedraw Units may be installed only in Bin sizes specified in the Chief Industries Catalog. The Chief Industries Sidedraw Unit or engineering approved systems are the only sidedraw units that can be installed in a Chief Grain Bin.

Note: When installing a Chief Sidedraw system the 1<sup>st</sup> baffles must be placed on 1<sup>st</sup> ring of bin at cave. The 1<sup>st</sup> wind ring also needs to be installed on 1<sup>st</sup> ring of bin, when using these systems.

Sidedraws systems are to only be used with dry grain. Do not use Sidedraws with any poor flowing product.

It is recommended that Sidedraws are placed in the 4<sup>th</sup>, 5<sup>th</sup>, or 6<sup>th</sup> bin from the base of the tank.

It is not recommended that Sidedraws be installed in Commercial Hopper tanks (CHT's)

Bins with sidedraw systems can NOT be loaded and unloaded from the sidedraw at the same time.

If multiple sidedraws are installed on a bin, only one sidedraw can be used at a time. If 2 sidedraws are installed in a bin, they must be placed 180 degrees apart.

It is required that the bin is coned from the center discharge to level the grain in the tank before refilling after the sidedraw has been used.

Prior to prolonged storage, grain should be cored or taken to a level condition.

## Section 2 - #5 Thru #16 V-Rib Roofs

### A. Roof Assembly

After the first 2 rings of the bin is erected raise the peak ring to the proper height listed in the chart below.

#### Standard Tanks

Tank Size	Height
05	11'-2 3/4"
06	12'-1 1/2"
07	13'-0 1/4"
08	13'-11"
09	14'-9 5/8"
10	15'-8 3/8"
11	16'-7 1/8"
12	17'-5 7/8"
14	17'-9 3/8"
16	19'-6 1/2"

#### Even Diameter Tanks

Tank Size	Height
05	NA
06	NA
07	NA
08	13'-7 7/8"
09	14'-6 1/4"
10	15'-4 5/8"
11	NA
12	17'-1 1/4"
14	17'-4 1/8"
16	19'-0 1/2"

**Height = (top of floor to bottom of peak ring with two rings of sidewall sheets installed)**

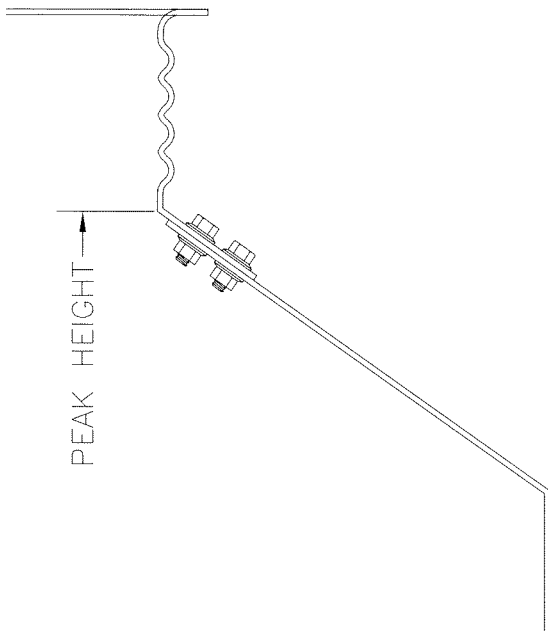

**#5 - #12**

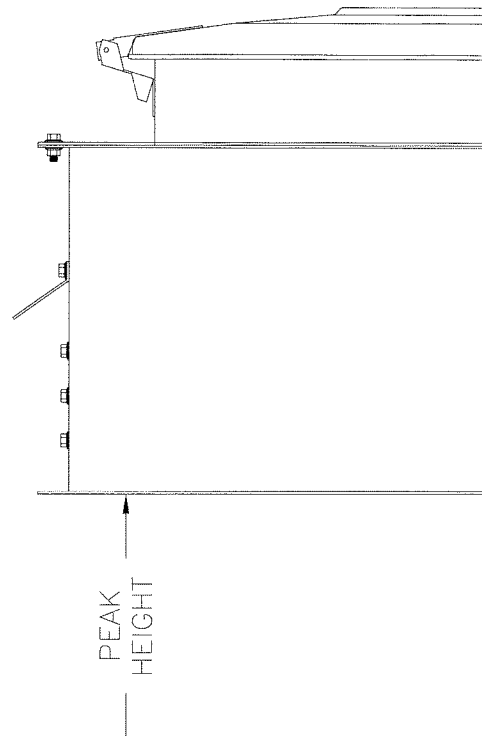

**#14 & #16**

**Important!** All roof panels are color coded for each tank size. The chart below lists the proper color code for each tank size roof panels.

<b>Tank Size</b>	<b>Roof Panel Color Code</b>
05	Green/White
06	Red
07	Yellow
08	Green
09	Blue
10	Orange
11	Gray
12	Brown
14	Brown/White
16	White

## B. Eave Clip Installation

Before installing roof panels, eave clips and hurricane clips must be installed to the inside of the top ring of the tank using 5/16" x 3/4" bin bolts. Leave clips loose until roof panels are installed.

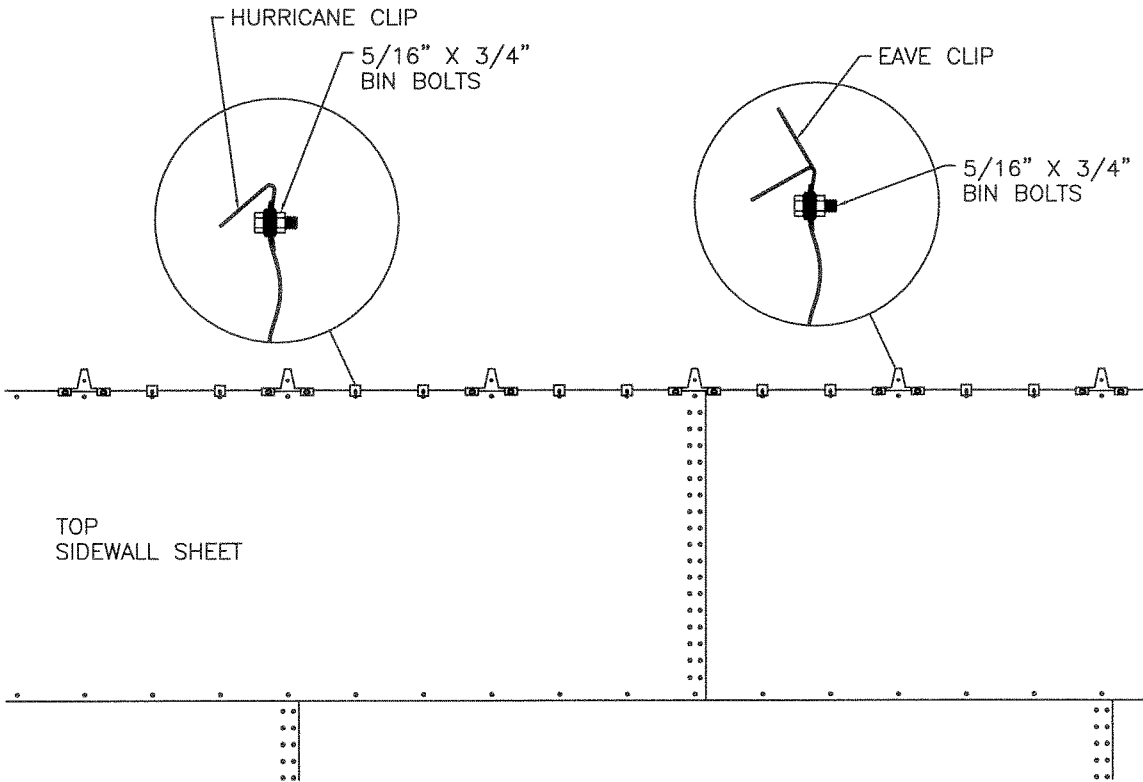
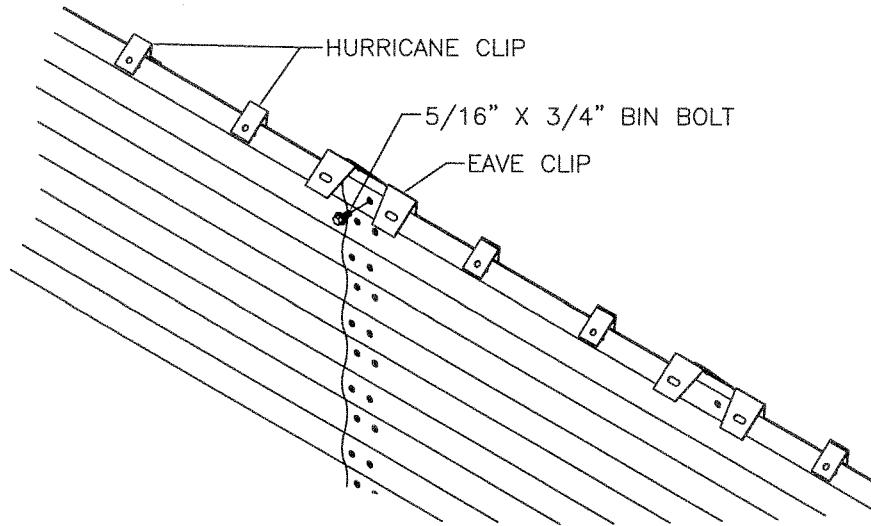

### *C. Roof Panel Installation (#5 - #12)*

Install 4 roof panels 90 degrees apart from each other by bolting the panels to the eave clips and peak ring.

Install the roof panels to the bottom side of the inner ring assemble and attach the roof panel ribs to the peak with 5/16" x 1-1/4" bin bolts.

Note: The roof panel to the right of the first panel is the roof ladder panel. Add the ladder rungs as the bolts are being installed. All ladder rungs are attached to the roof panel ribs with 5/16" x 3/4" Bin bolts.

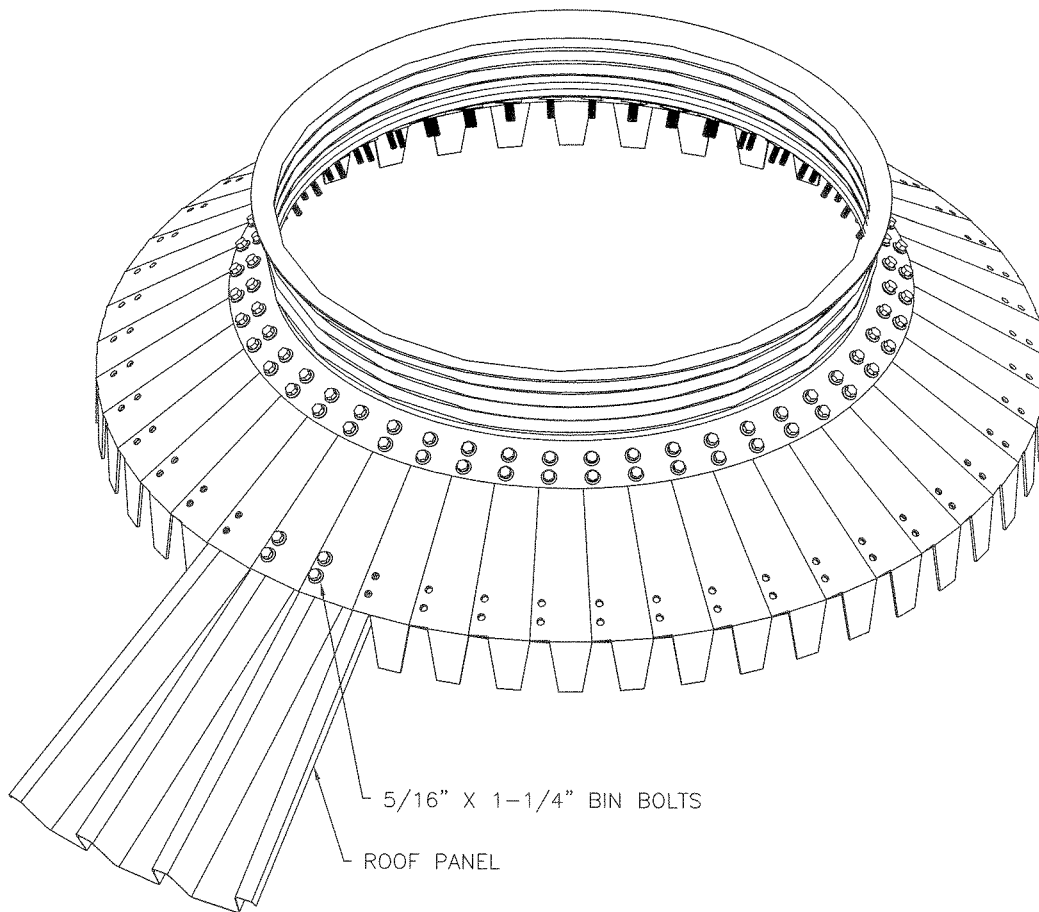



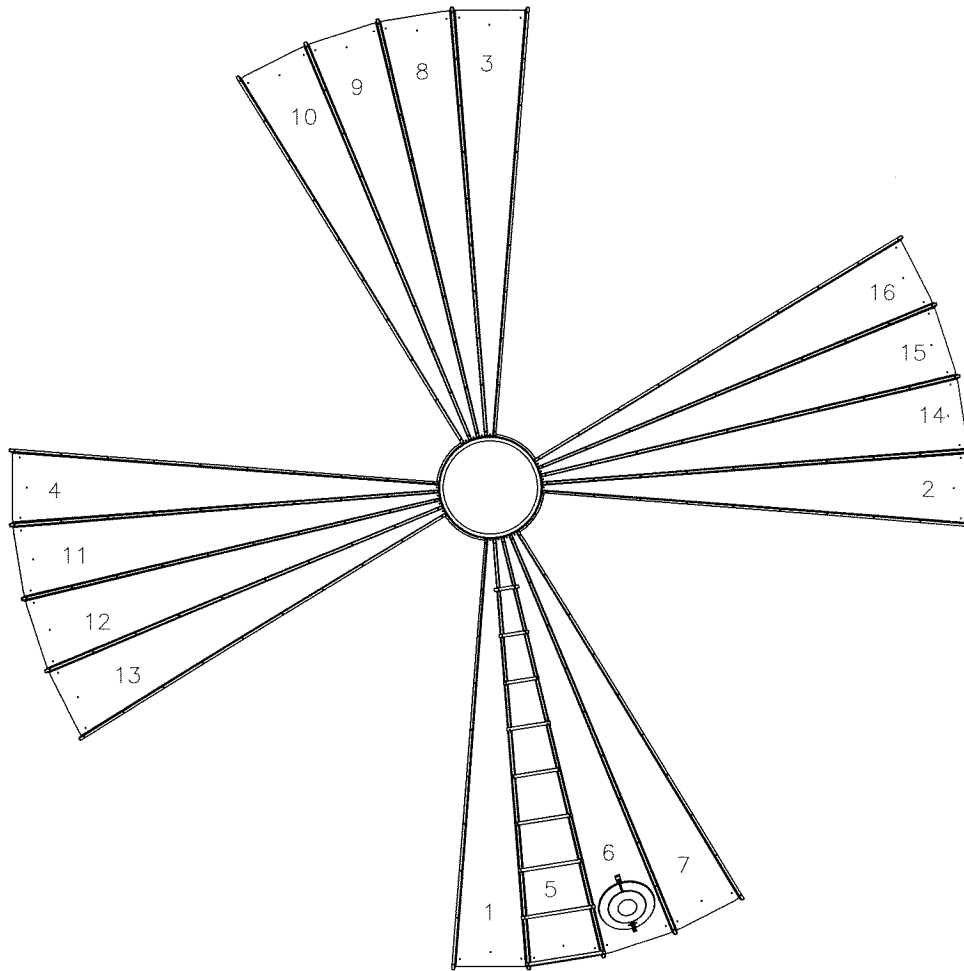

*Typical Roof Top View*

Install roof panels as shown. Bolt roof panels together with 5/16 x 3/4 Bin Bolts. Be sure to check peak ring periodically while installing roof panels to make sure it is keep level.

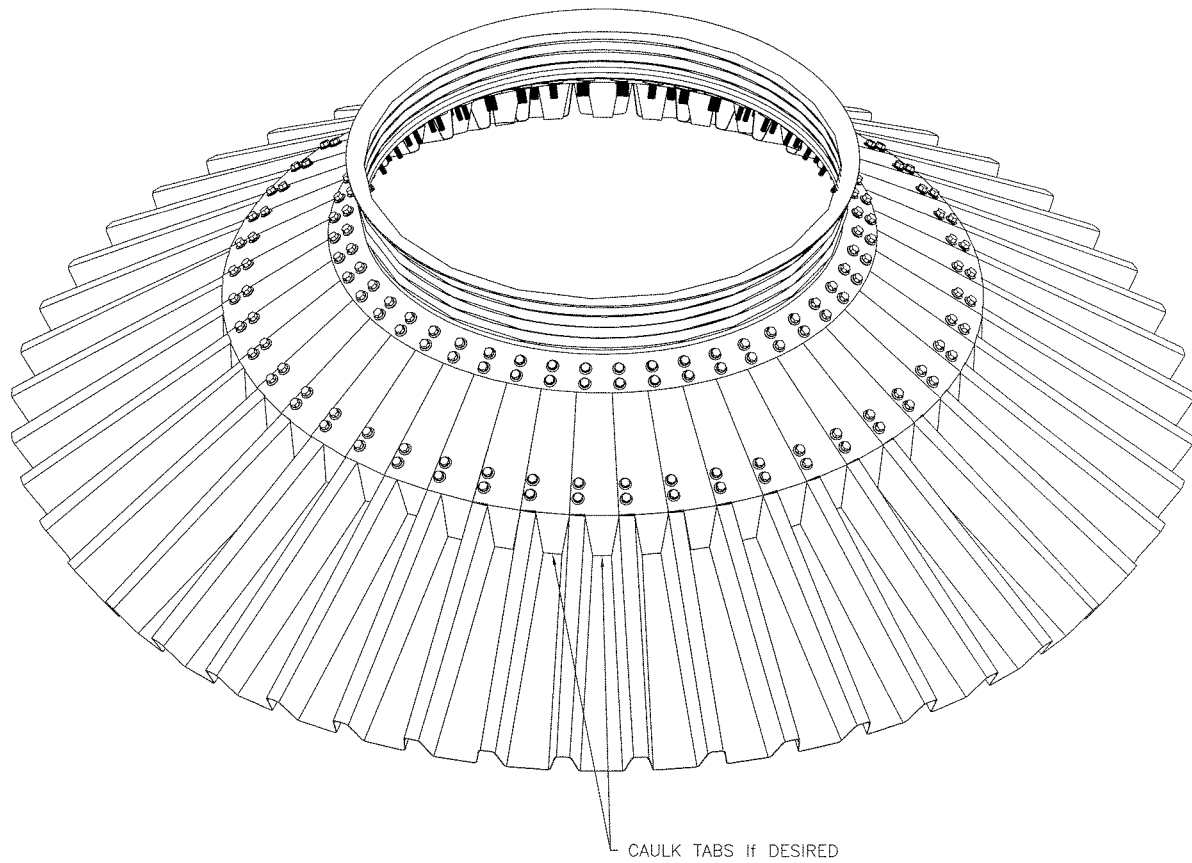

After all roof panels have been installed, the tabs between the ribs can be caulked if desired.

#### *D. Roof Panel Installation (#14 & #16)*

Attach flashing clips to peak ring with 7/16" x 1-1/4" bin bolts. Place plastic foam around peak ring under flashing clips.

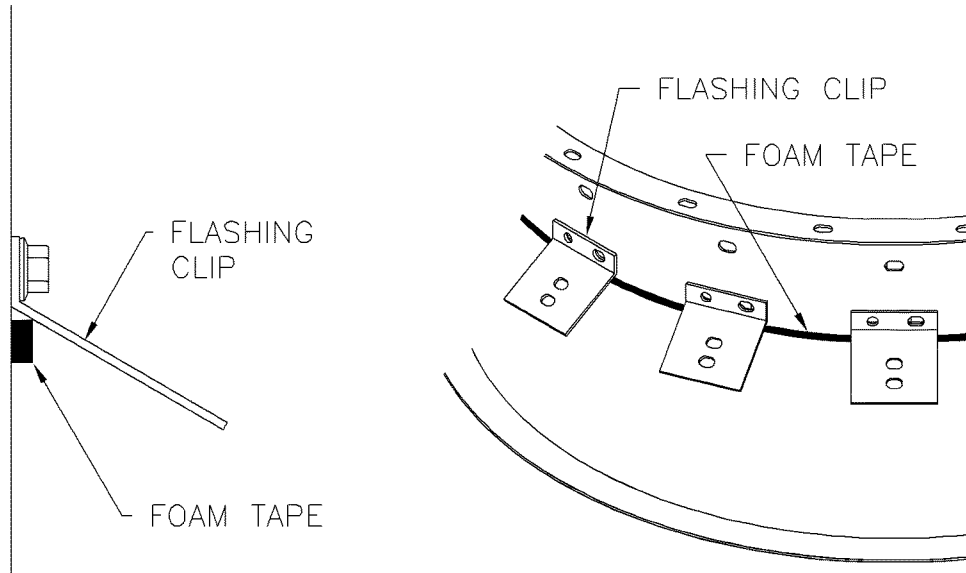

Attach roof panel flashing extensions to flashing clips with 7/16" x 1-1/4" bin bolts. Check that flashing extension is aligned properly with inner ring.

Install 4 roof panels 90 degrees apart from each other by bolting the panels to the eave clips and inner ring.

Note: The roof panel to the right of the first panel is the roof ladder panel. Add the ladder rungs as the bolts are being installed. All ladder rungs are attached to the roof panel ribs with 5/16" x 3/4" Bin bolts.

Place Foam on edge of extension to seal between extensions.

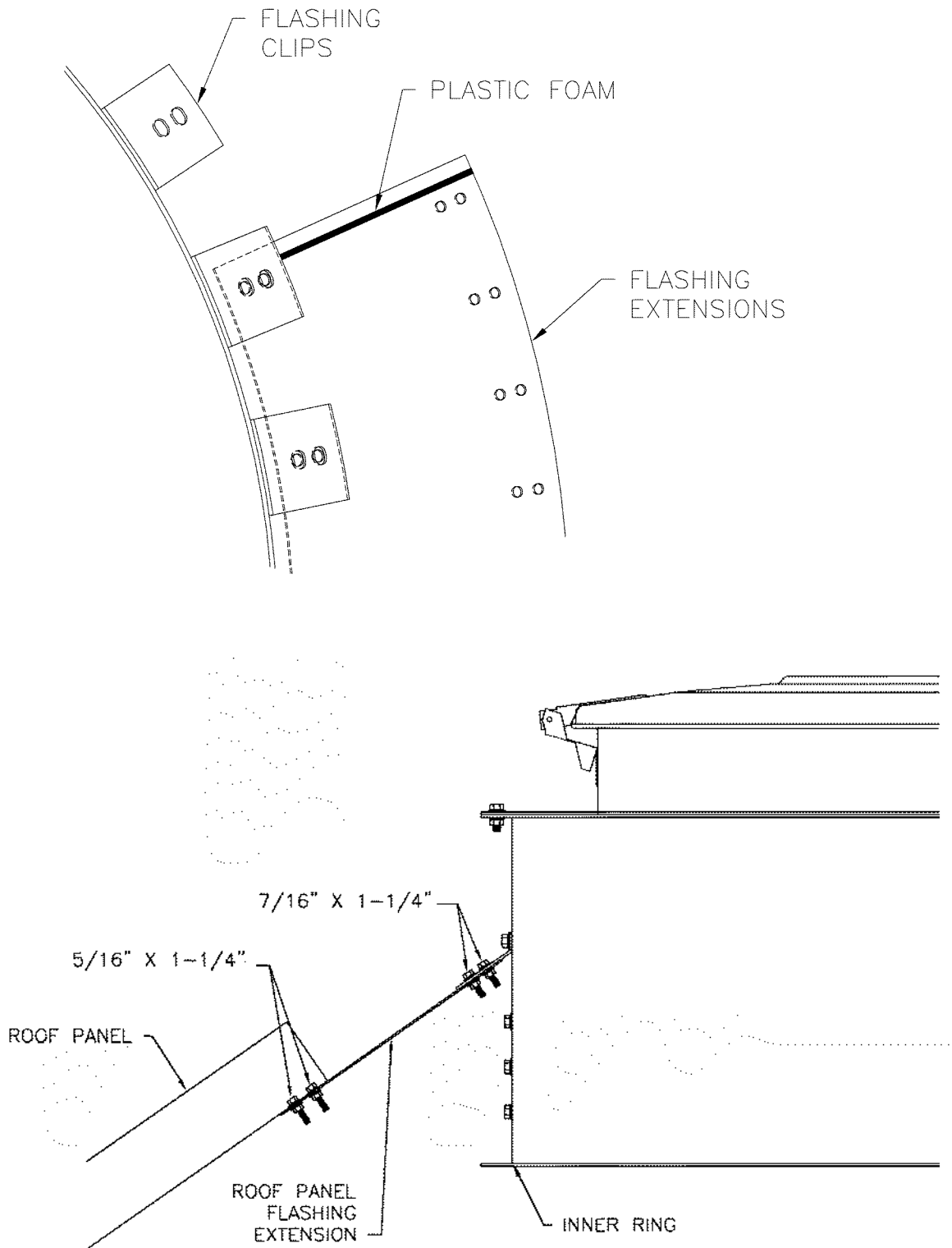

#14

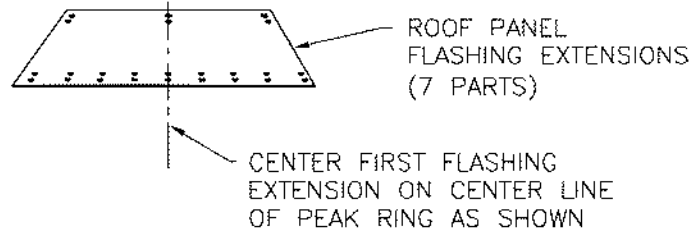
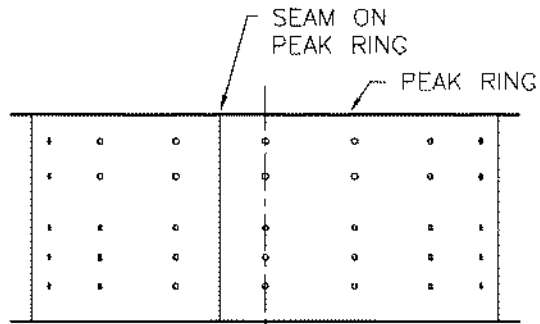

#16

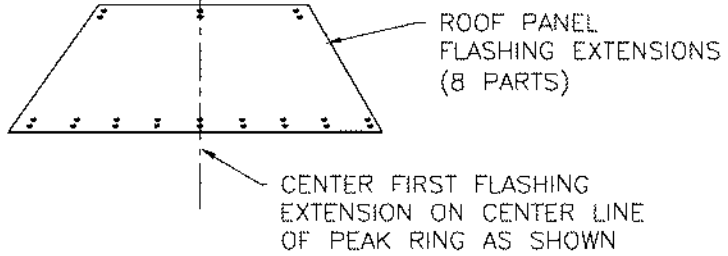
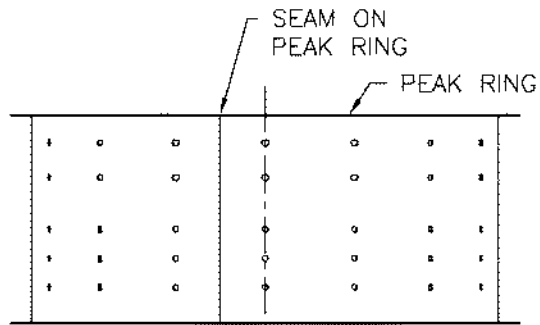

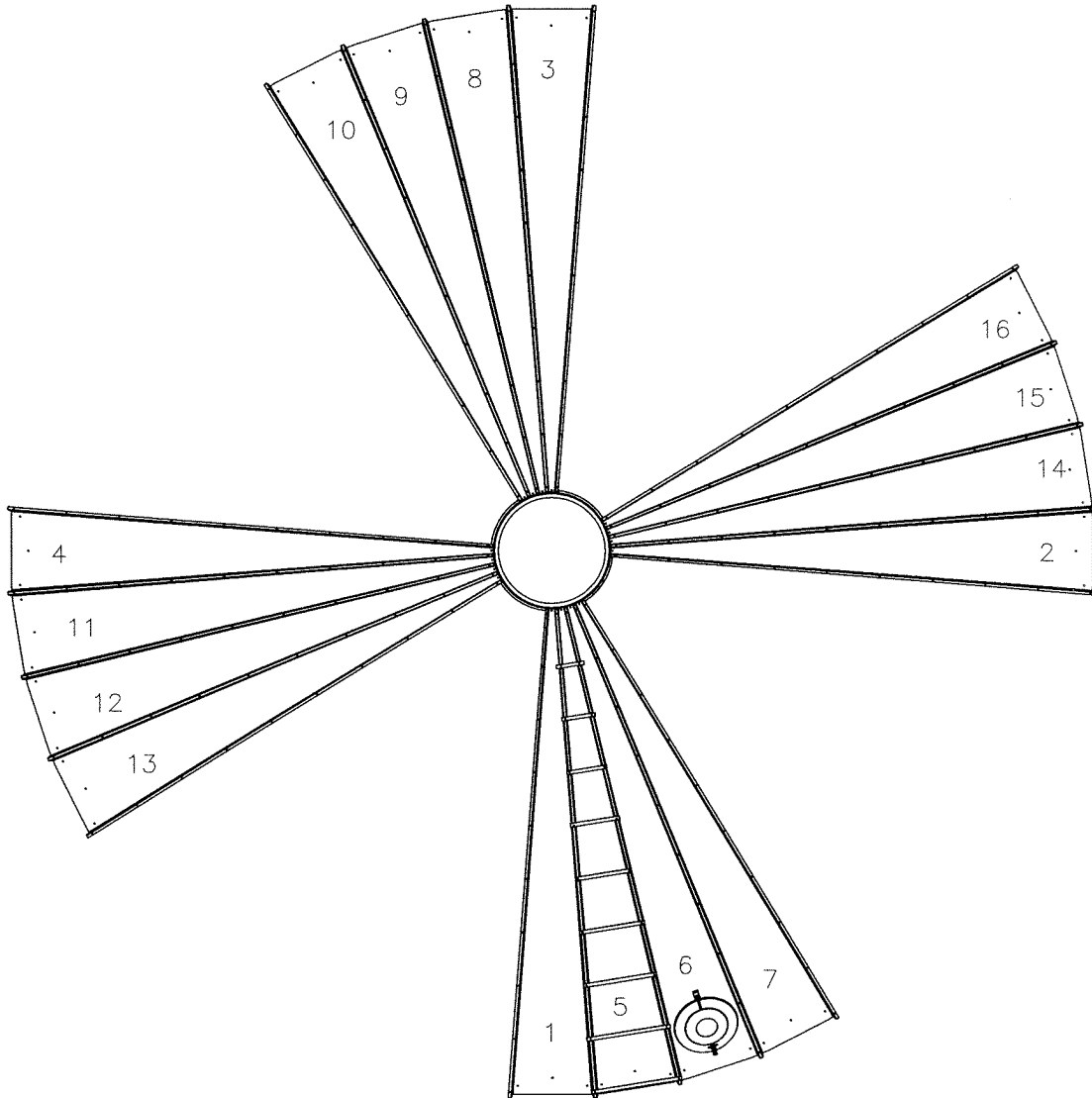

*Typical Roof Top View*

Install roof panels as shown. Bolt roof panels together with 5/16 x 3/4 Bin Bolts. Be sure to check inner ring periodically while installing roof panels to make sure it is keep level.



Install Roof rib stiffeners on the roof panel the roof ladder is on as shown below.  
(Holes in roof panel will need to be reamed out for the 5/16" x 3/4" Bin Bolts.)

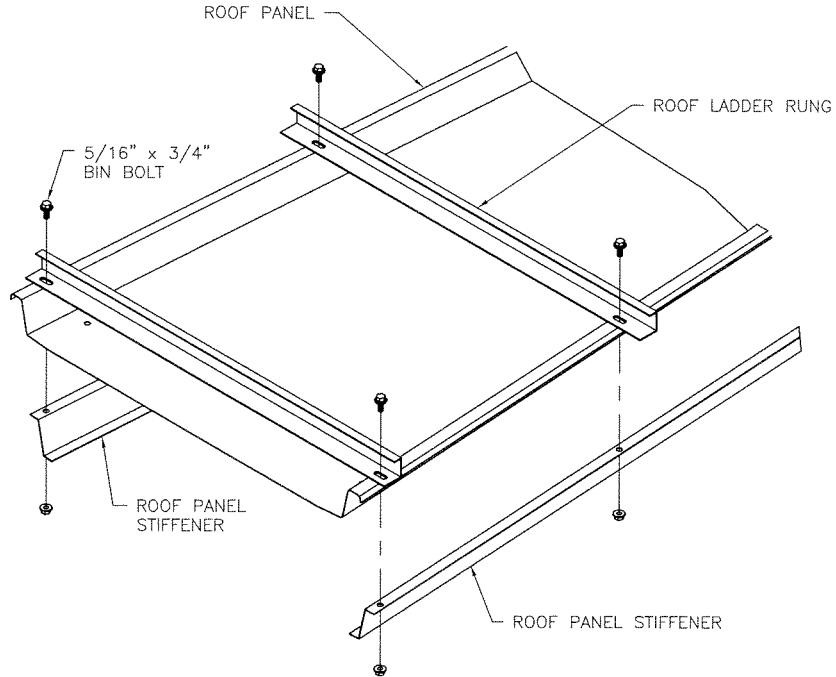

#06 and #07 Roof Panel Rib Stiffeners

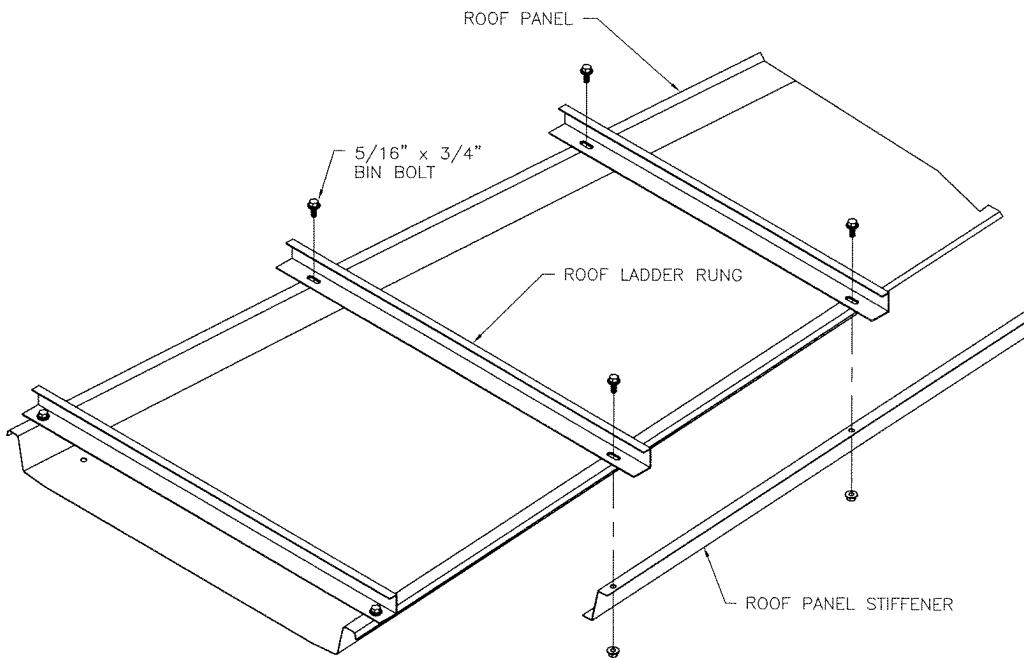

#08 and #09 Roof Panel Rib Stiffeners



## F. Reinforcing Rings

One outside reinforcing ring is required on #10, #11 and #12 roofs, and one outside and one inside reinforcing ring are required on the #14 and #16 roofs. Add reinforcing rings, connectors and clips as roof panels are being installed.

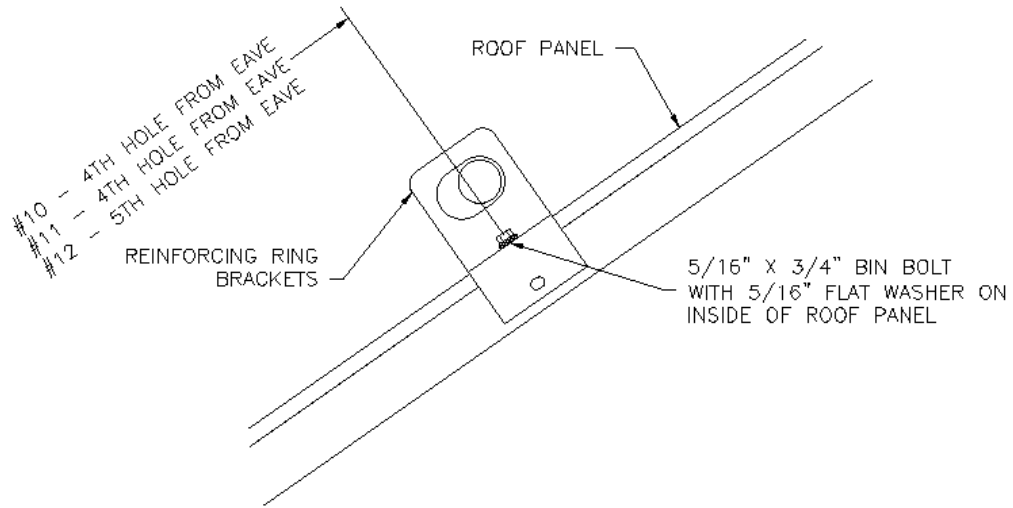

### *Reinforcing Ring Installation Detail for #10, #11, and #12 Roofs*

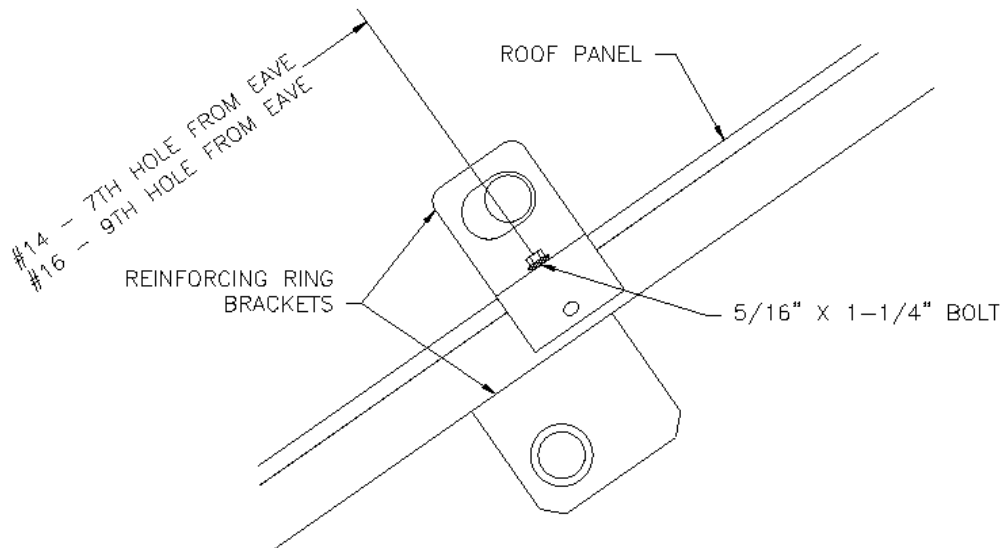

### *Reinforcing Ring Installation Detail for #14, and #16 Roof*

Refer to the chart below for proper sequence of using threaded and non-threaded connectors

V-Rib Roofs #10 thru #16				
Bin Size	Bridging Ring Segments	A	B	Sequence of Connectors
		Threaded Connectors	Non-Threaded Connectors	
#10	5	2	3	B A B A B
#11	6	3	3	B A B A B A
#12	6	3	3	B A B A B A
#14	6 Inside	3	3	B A B A B A
	6 Outside	3	3	B A B A B A
#16	7 Inside	3	4	A B A B B A B
	7 Outside	3	4	A B A B B A B

Tank Size	Bridging Ring Color Code
10	Orange/Black
11	Brown/White
12	Brown/Black
14	White/Black
16	Blue/Black

There are (4) 1-1/4” nuts per threaded connector. Install both nuts centered on the threaded rods before installing them on the roof. As the reinforcing rings are be installed on the roof, place a threaded connector into the end of the pipe and add the next pipe. When all reinforcing rings and threaded connectors are installed, expanded the threaded connectors equally around the roof until the roof is slightly convex.

Note: on #14 and #16 roofs, Tighten the outside ring completely, then tighten the inside ring until snug. The outside ring connectors, maybe bolted to the pipes after tightening, by field drilling the pipe and connectors, but is not required.

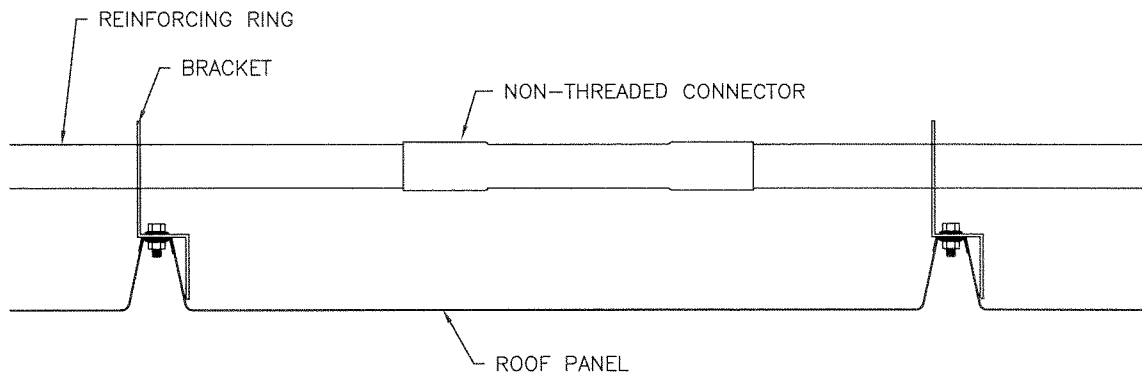
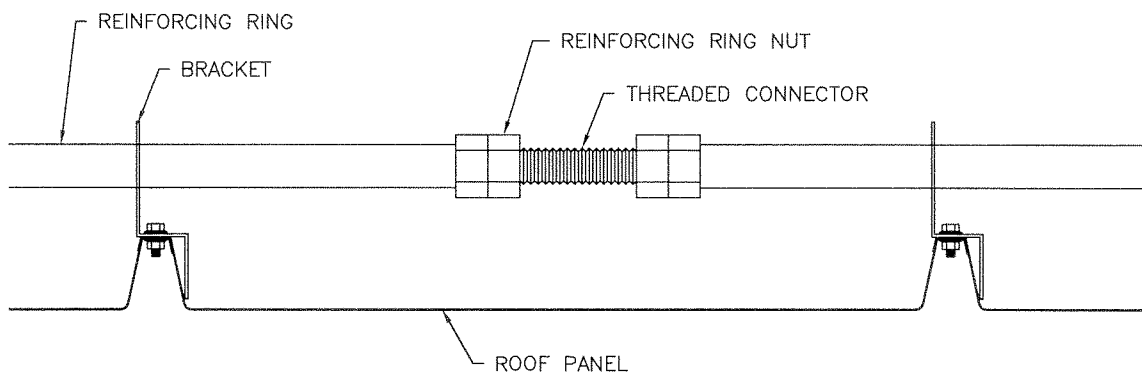
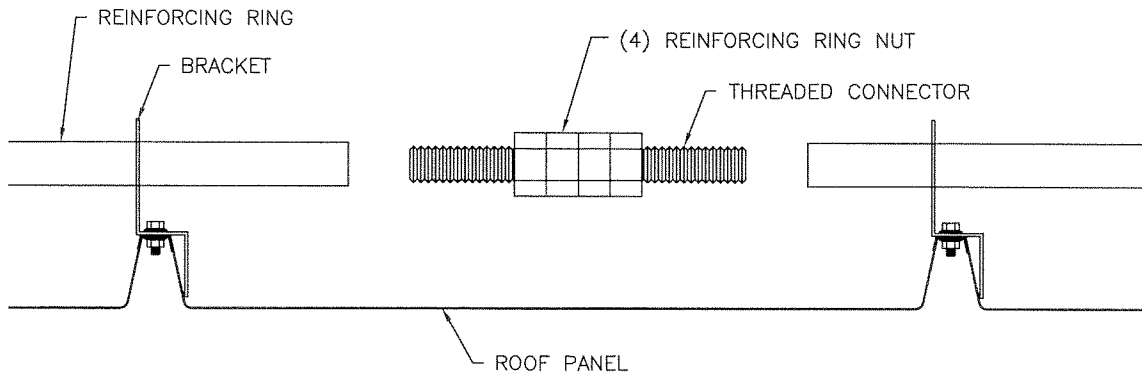

## G. Working Ring

#5 thru #12

Field locate and Install the working ring to the roof panels as shown, with 5/16" x 3/4" Bin bolts. The working ring clips are to be evenly spaced around the ring. Connect the working ring segments together with the connectors as shown below.

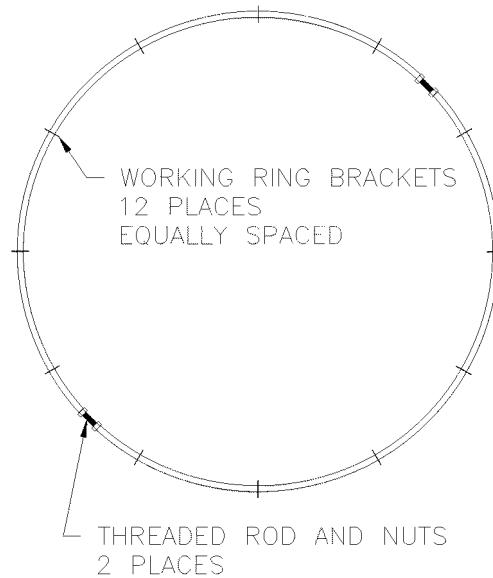
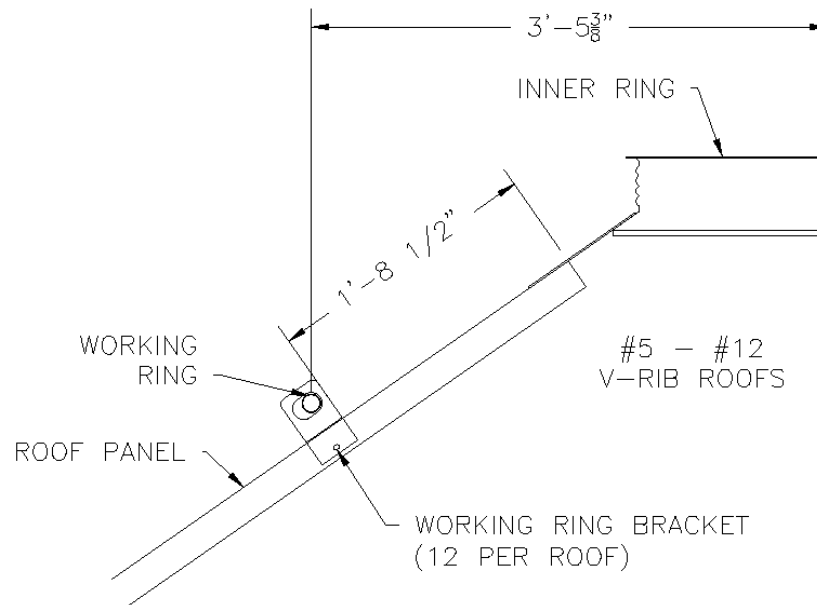

# #14 & #16 Working Ring

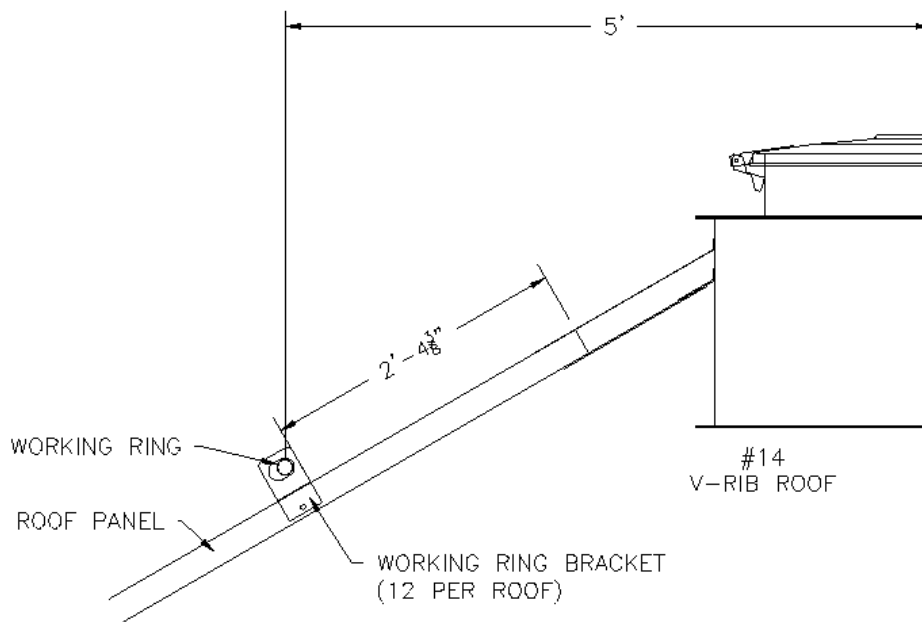
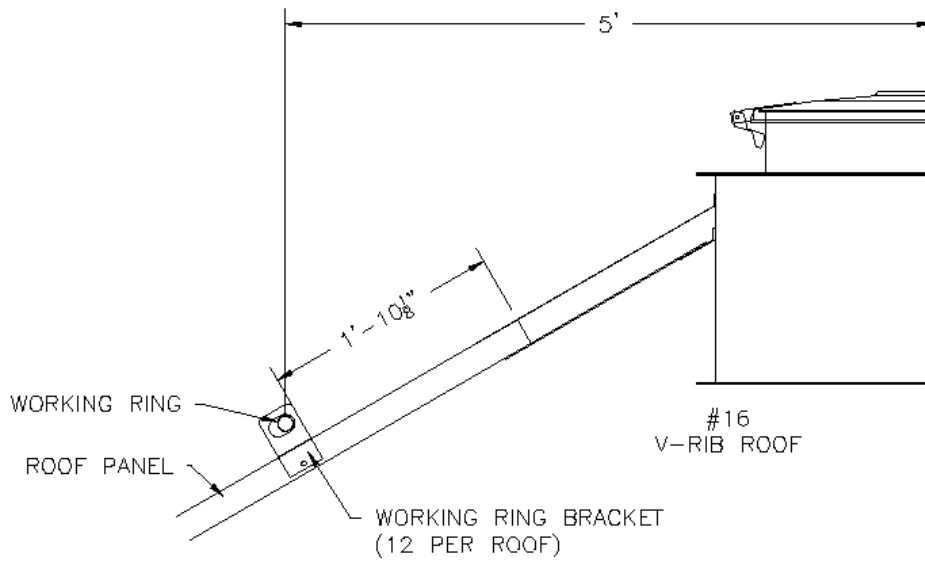

### H. Top Filler Lid (Standard on #5 thru #16 Roofs)

- Step 1. Bolt lower lid hinge bracket to the inner ring at the (3) pre-punched holes in the inner ring using (3) 5/16" x 3/4" bin bolts and nuts,
- Step 2. Bolt the upper lid hinge bracket to the lower hinge bracket with 1/4" x 3/4" bolts, Double nut so the hinge is secure while still allowing the hinge to rotate.
- Step 3. Bolt the upper lid hinge bracket to the lid with (3) 5/16" x 3/4" bin bolts and nuts
- Step 4. Bolt the lid latch brackets at the pre-punched holes in the side of the top lid, using #10 machine screw and nut. Use a hole that is most directly above the holes in the inner ring.
- Step 5. Mount the hook anchor bracket on top of the roof panel using the same bolt that attaches the roof panel to the inner ring.
- Step 6. Attach the rubber hook to the hook anchor bracket with 1/4" x 1-1/4" bolt and nut provided.

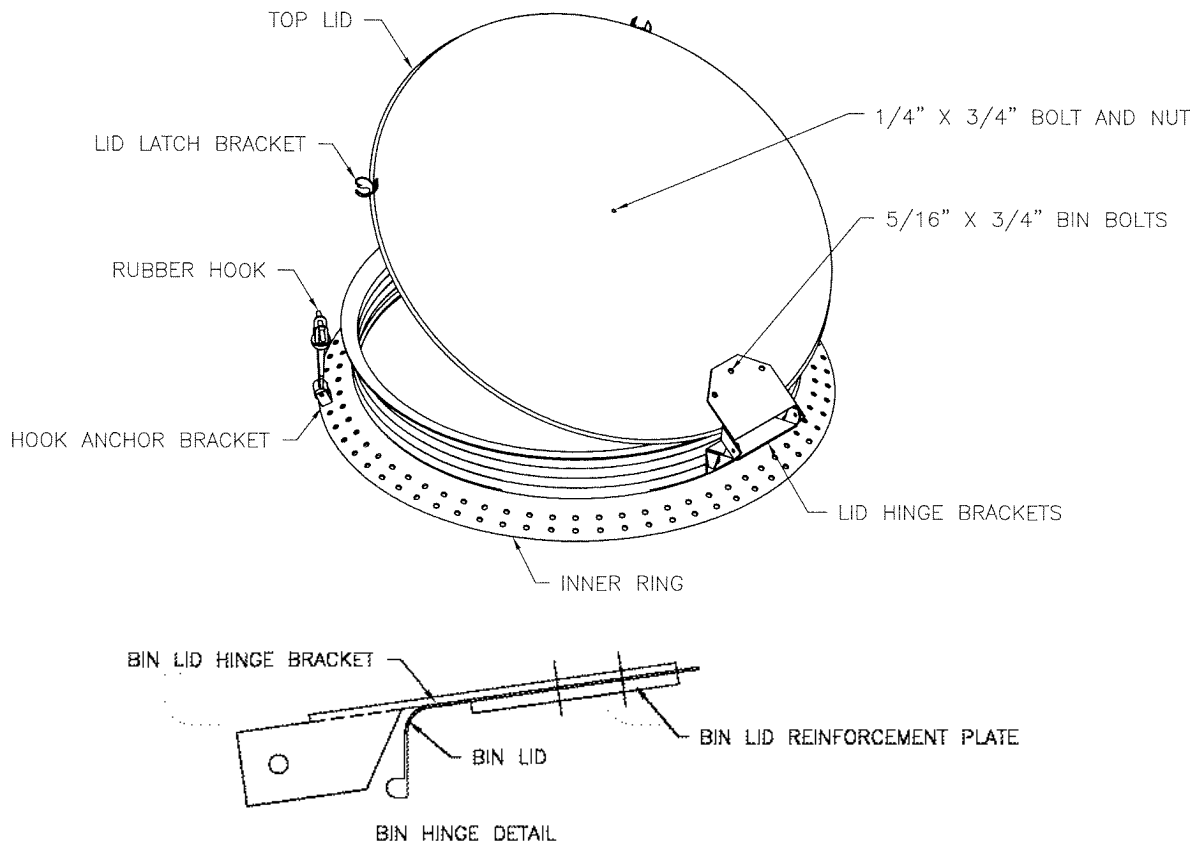

## I. Manhole Lid

- (1) Install manhole lid as shown below. Note that manhole hinge should be installed toward top of bin.

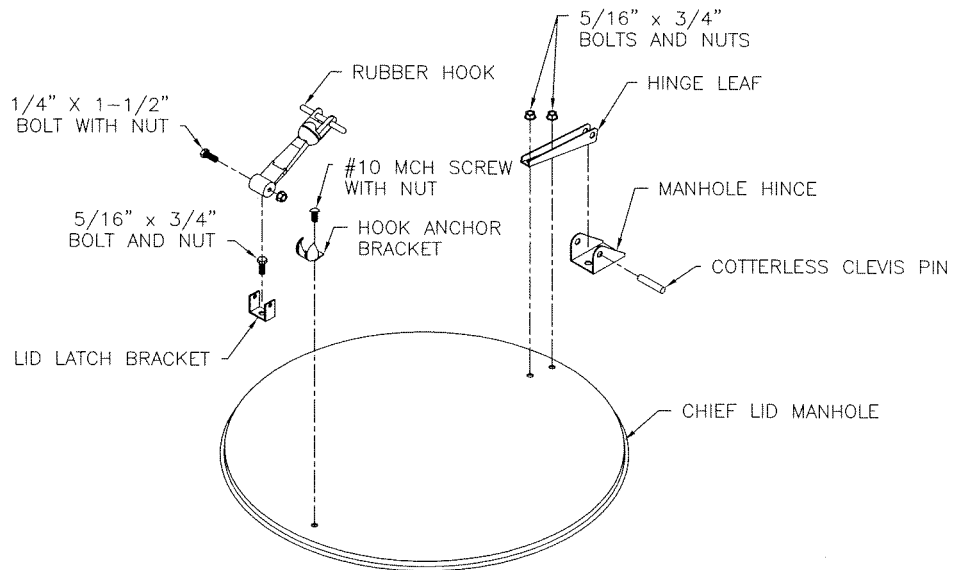

*Assembling Manhole Lid*

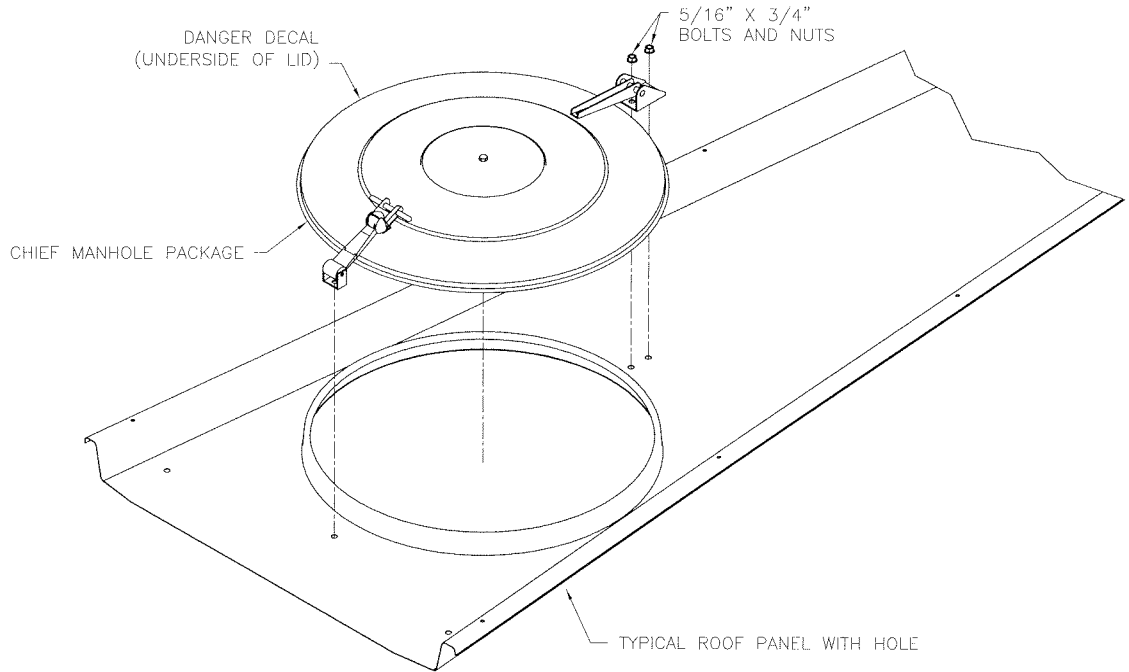

*Attaching Manhole Assembly to Roof Panel*

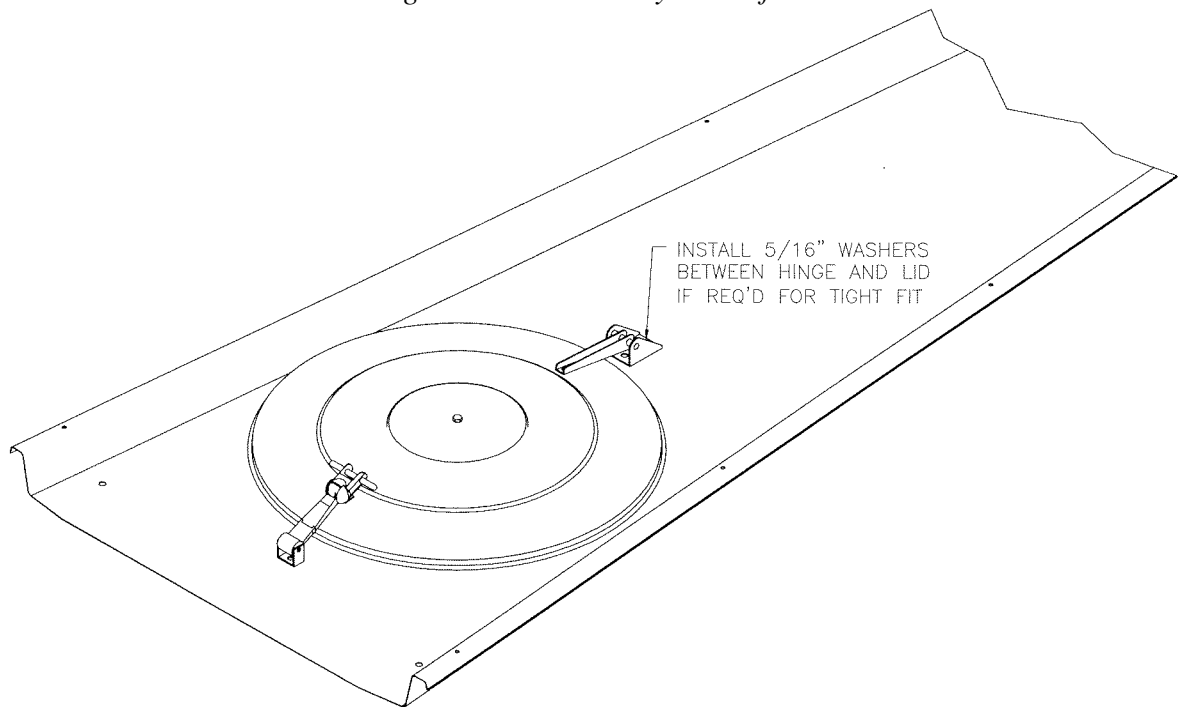

*Complete Assembly*

**NOTE: Leaf to lid and hinge to roof panel bolts are to be installed with heads inside.**





### *J. Roof Ladder*

For ease in opening the top lid, roof ladder should be placed approximately 90° from hinge holes located in the side of the inner ring.

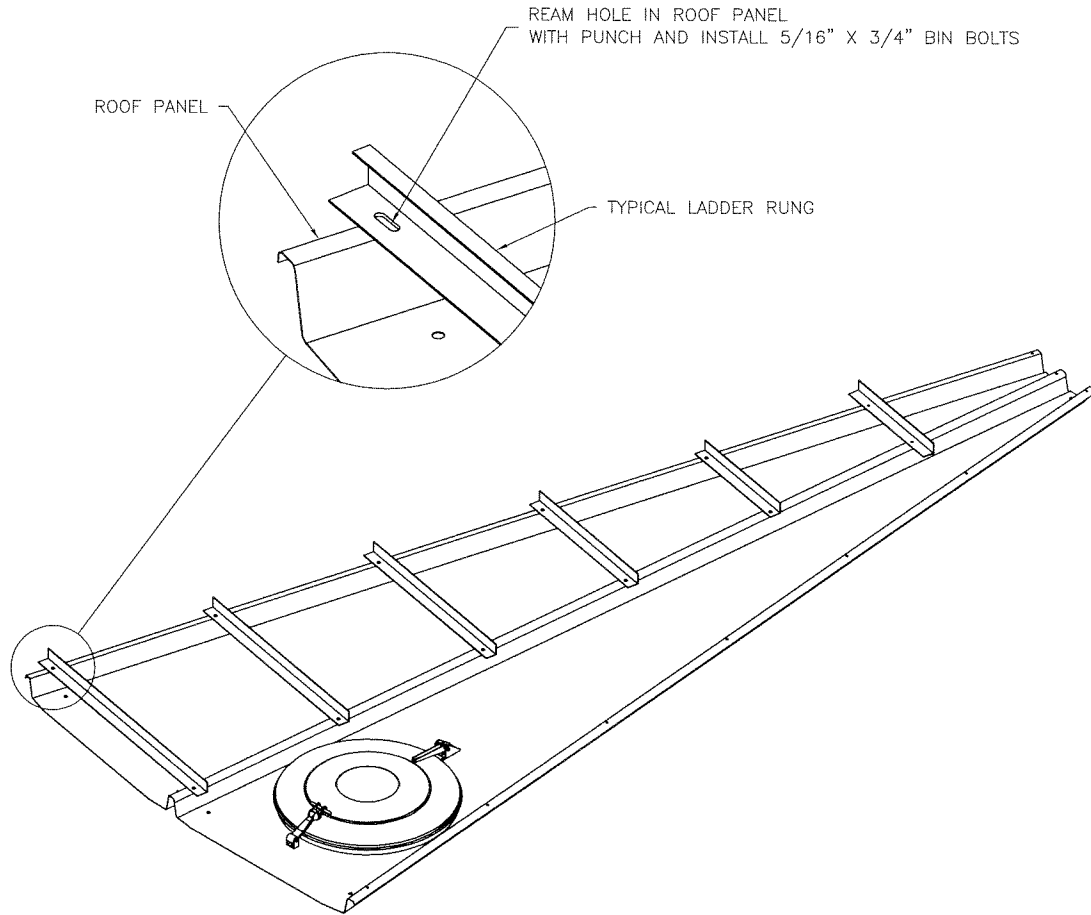

## K. Roof Vents (optional)

### Goose Neck Vent Installation

Refer to the bulletin that comes with the vent for installation procedures

Locate Goose Neck Vent on the desired roof sheet. Typically slide Goose Neck Vent up the roof sheet (Toward the small end) until the corners of the base intersect the roof sheet ribs.

Using the base as a template, mark and drill the 1 1/32" diameter mounting holes.

Apply (2) two beads of butyl sealant or mastic sealant as shown, between the Goose Neck Vent base and roof sheet. Leave a 1" gap at the lower side of the outside bead.

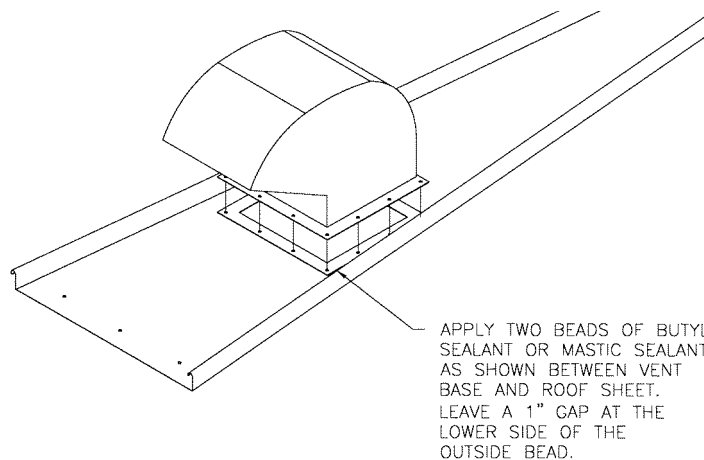

Assemble Goose Neck Vent to roof sheet using 5/16" x 3/4" hex bin bolts and nuts. Tighten all bolts and check sealant along upper end of Goose Neck vent base for any gaps or pockets. Apply extra sealant as required.

Peen up edge on inside of Gooseneck Vent to make a watertight seal. The lip should be approximately 1" all the way around.

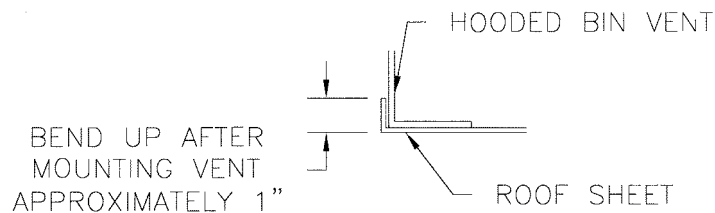

**Do Not Weld** Gooseneck vent to roof, as rusting will result.

## Mushroom Vent Installation

1. Refer to the bulletin that comes with the vent for installation procedures
2. Mushroom vents are attached to pre-punched roof sheets with holes at the lower end of the sheets.

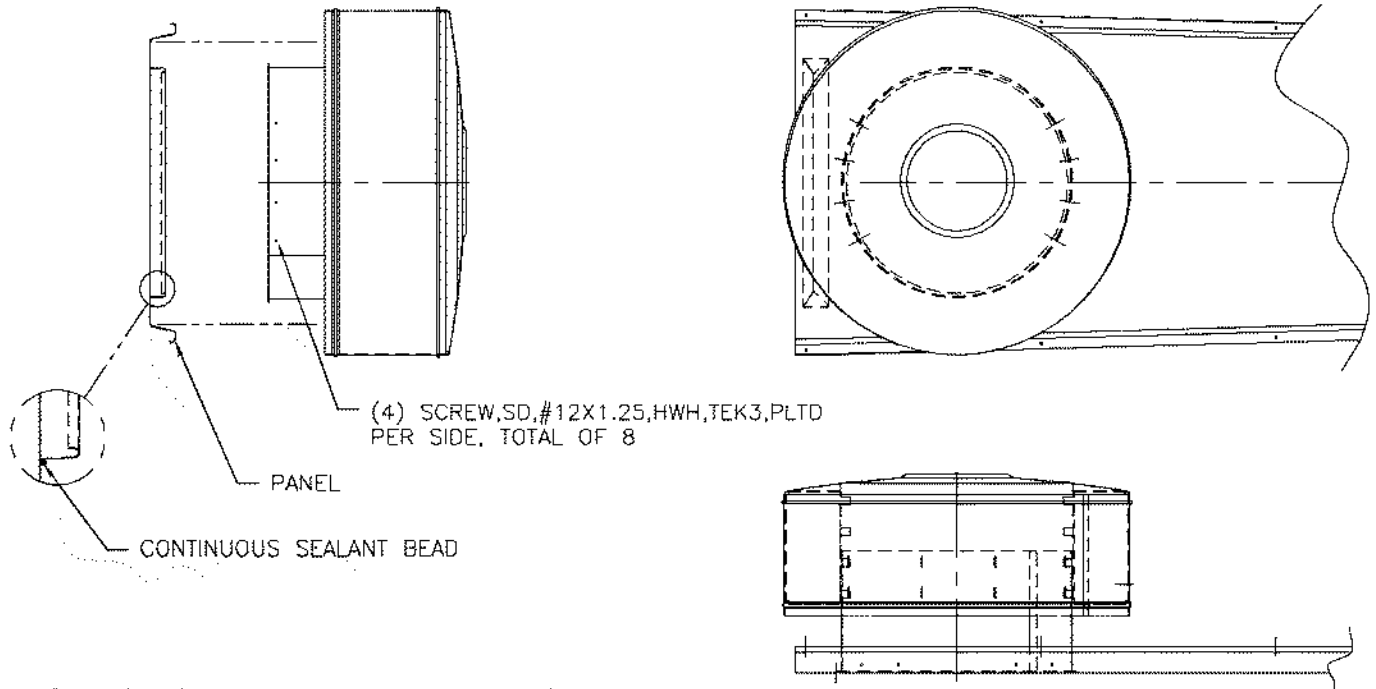

### NOTES: SEAL MUSHROOM VENT TO ROOF PANEL

1. On CB22 through CB50 model bins, use the silicone tube caulking supplied with the roof hardware package and apply a continuous bead of sealant along the base of the extruded manhole lip (see detail).
2. On CB20 and smaller model bins, use the bead caulking supplied with the roof hardware package and apply a continuous bead of sealant along the base of the extruded manhole lip (see detail).

*L. Temperature Cable Supports (optional)*

**Note: Temperature cables can only be installed in bins with V-Rib roofs up to 12 rings tall.**

<b>#5 - #16 Temperature Cables</b>		
<b>Bin Size</b>	<b>Total # Temp. Cables</b>	<b>Temp. Cables #/Radius</b>
#5	1	0"
#6	1	0"
#7	1	0"
#8	3	84"
#9	3	88"
#10	3	91"
#11	3	103"
#12	3	111"
#14	1-4	0"-174"
#16	1-5	0"-196"

On roof panels that temperature cables are to be installed, attach roof panel ribs with 5/16" x 1-1/4" bin bolts, Install Rib supports under roof ribs with double nuts as shown. Attach rib supports together with splice plates. Attach angle support to rib supports with 1/2" x 1-1/2" bolts. Attach temperature cable to angle support per temperature cables manufactures instructions.

Note:

#10 thru #16 requires 2 rib supports per roof sheet.

#8 and #9 roofs do not require splice plates; there is only one rib support per roof sheet.

Center Temperature cables can be attached to the peak ring and do not require a support kit.

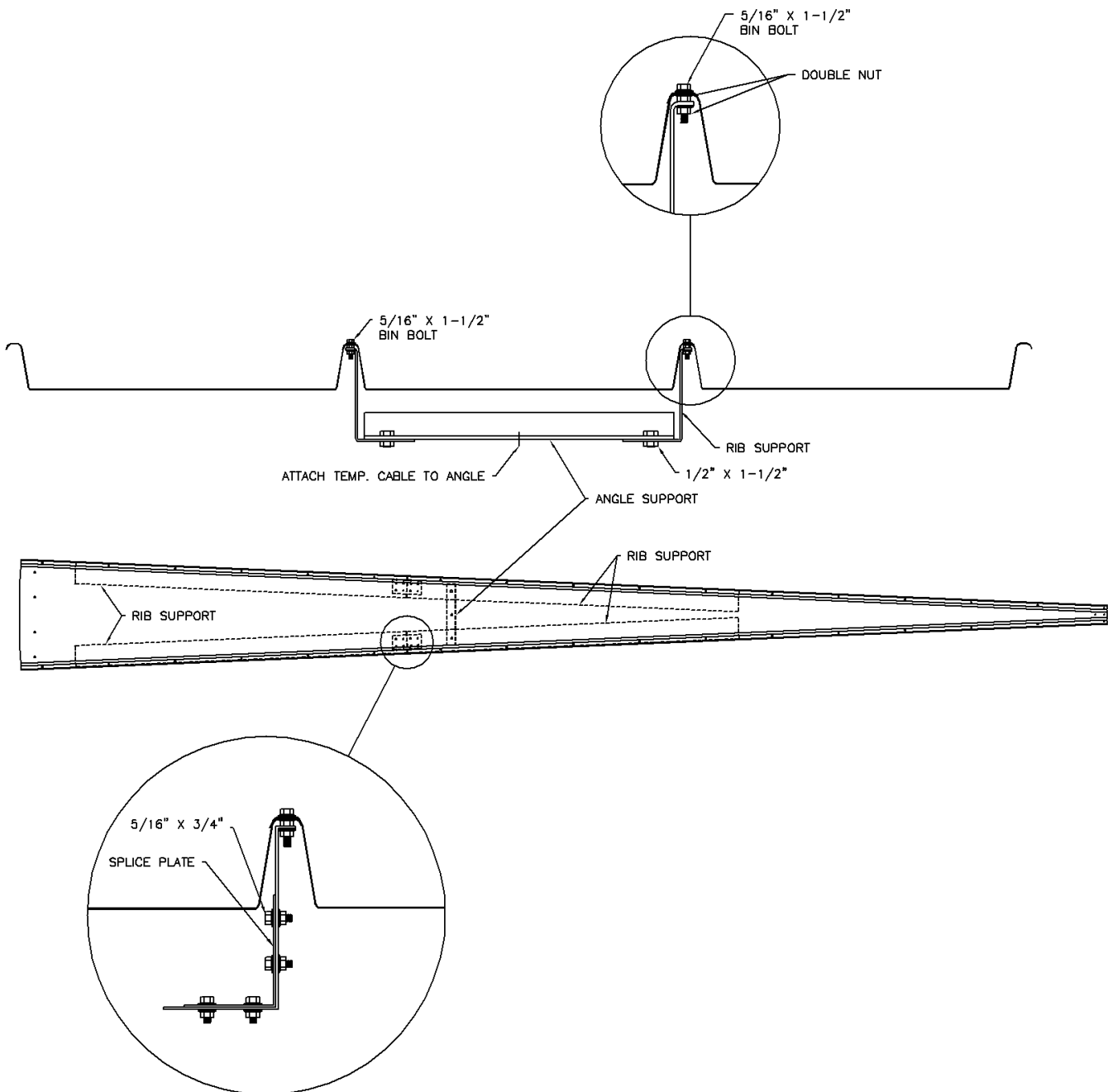

### *Eave Seal Kit (optional)*

An optional eave seal kit can be added to the top sidewall sheet as shown.

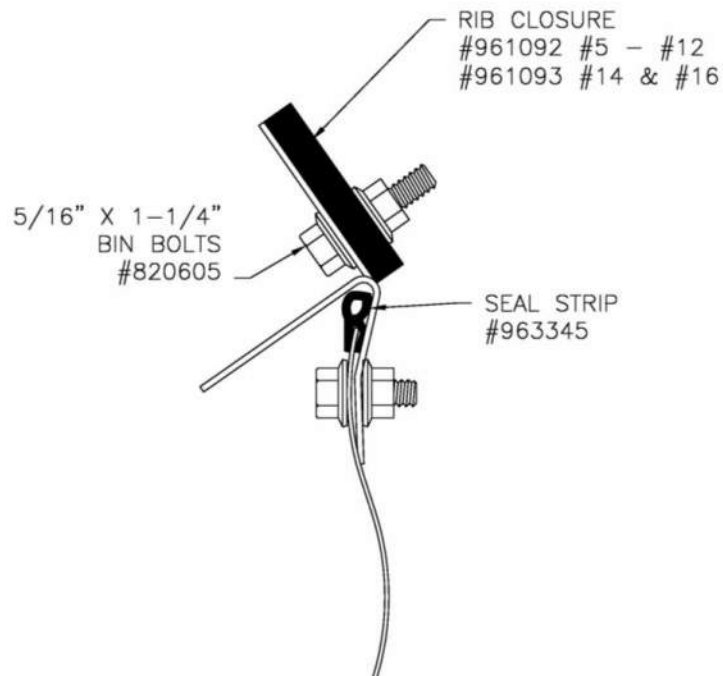
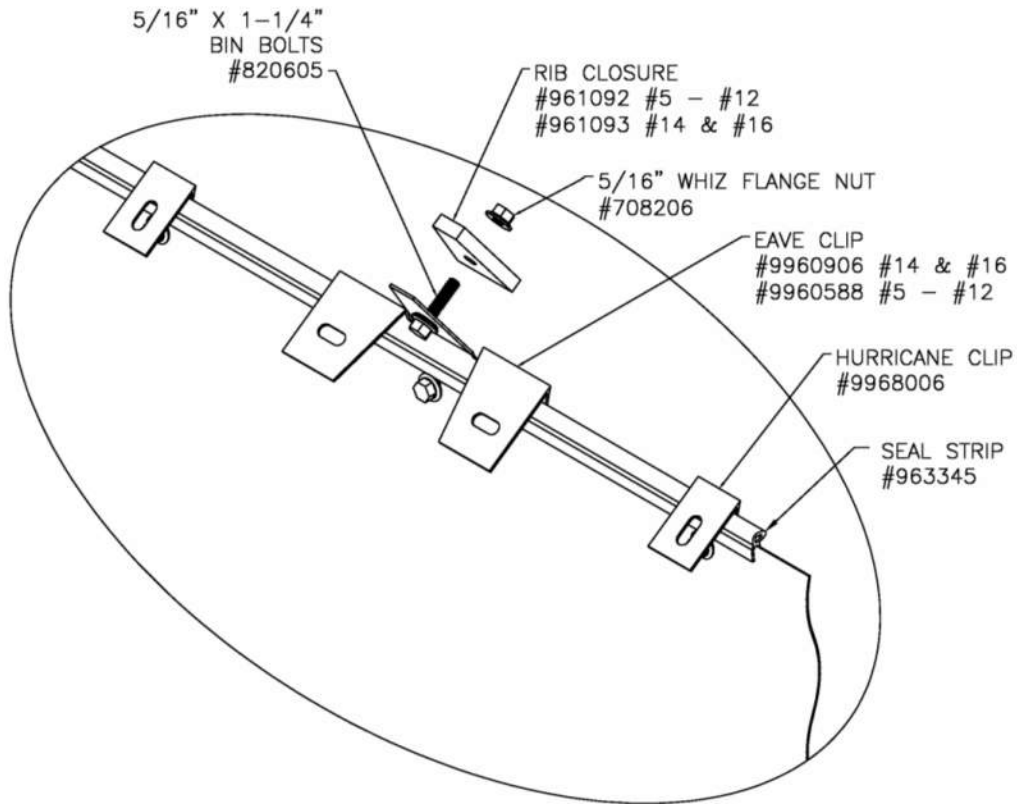

**CHIEF** 

CHIEF INDUSTRIES, INC.

Agri/Industrial Division

Chief Industries, Inc.

4400 East 39<sup>th</sup>

Kearney, NE