

ITEM	QTY	PART NO.	DESCRIPTION
1	1	104789	BULLETIN 1188 WALK DR TIE BACK
2	5	209270	SCREW MCH #8-32X1.25 RD HEAD
3	5	708214	NUT #8-32 HEX PLATED
4	1	708644	BAG PLASTIC 8X9X.002
5	1	960456	SOUTHCO #37-10-086-10 T-HANDLE

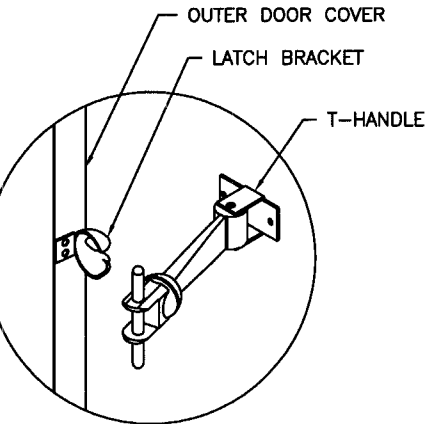

- STEP 1: COMPLETELY OPEN OUTER COVER AGAINST SIDEWALL SHEET
- STEP 2: POSITION T-HANDLE ON SIDEWALL IN A LOCATION THAT IS EASILY REACHED FROM THE GROUND
- STEP 3: MARK AND DRILL (2) TWO $\phi 3/16$ " HOLES, AND MOUNT T-HANDLE WITH (2) TWO #8 MACHINE SCREWS TO THE SIDEWALL SHEET
- STEP 4: POSITION THE LATCH BRACKET ON THE SIDE OF THE OUTER DOOR COVER AND MARK AND DRILL (2) TWO $\phi 3/16$ " HOLES, AND MOUNT THE LATCH BRACKET WITH (2) TWO #8 MACHINE SCREWS

ALL DIMENSIONS ARE IN INCHES WITH METRIC EQUIVALENTS IN BRACKETS <input type="checkbox"/>	MIN. MAT'L GA.	FIN. WT.
---	----------------	----------

C		
B		
A		
ERO NO.		DATE
REVISIONS		
TOLERANCES UNLESS OTHERWISE SPECIFIED		
FRACTIONS $\pm 1/32$		
DECIMALS $\pm .031$		
ANGLES $\pm 1/4$		

CHIEF

THIS DRAWING AND ALL INFORMATION THEREON IS THE PROPERTY OF CHIEF AGRI/INDUSTRIAL, Kearney, Nebraska
IT IS LOANED CONFIDENTIALLY AND MUST NOT BE USED IN ANY WAY DETRIMENTAL TO CHIEF INDUSTRIES INC.

AUTHORIZED		
BY	DATE	
DRAWN	CRR	04-24-03
CHECKED		
APPROVED		

PART NAME		
BULLETIN 1188 WALK DR TIE BACK		
MATERIAL FOR PART #960456 WALK DOOR TIE BACK		
WALK DOOR TIE BACK INSTALLATION INSTRUCTIONS		
SIZE	SCALE	MARK
B	1/16"=1"	PART NO. (C910) 104789