

NOTES: SEAL MUSHROOM VENT TO ROOF PANEL

1. On CB22 through CB50 model bins, use the silicone tube caulking supplied with the roof hardware package and apply a continuous bead of sealant along the base of the extruded manhole lip (see detail).
2. On CB20 and smaller model bins, use the bead caulking supplied with the roof hardware package and apply a continuous bead of sealant along the base of the extruded manhole lip (see detail).

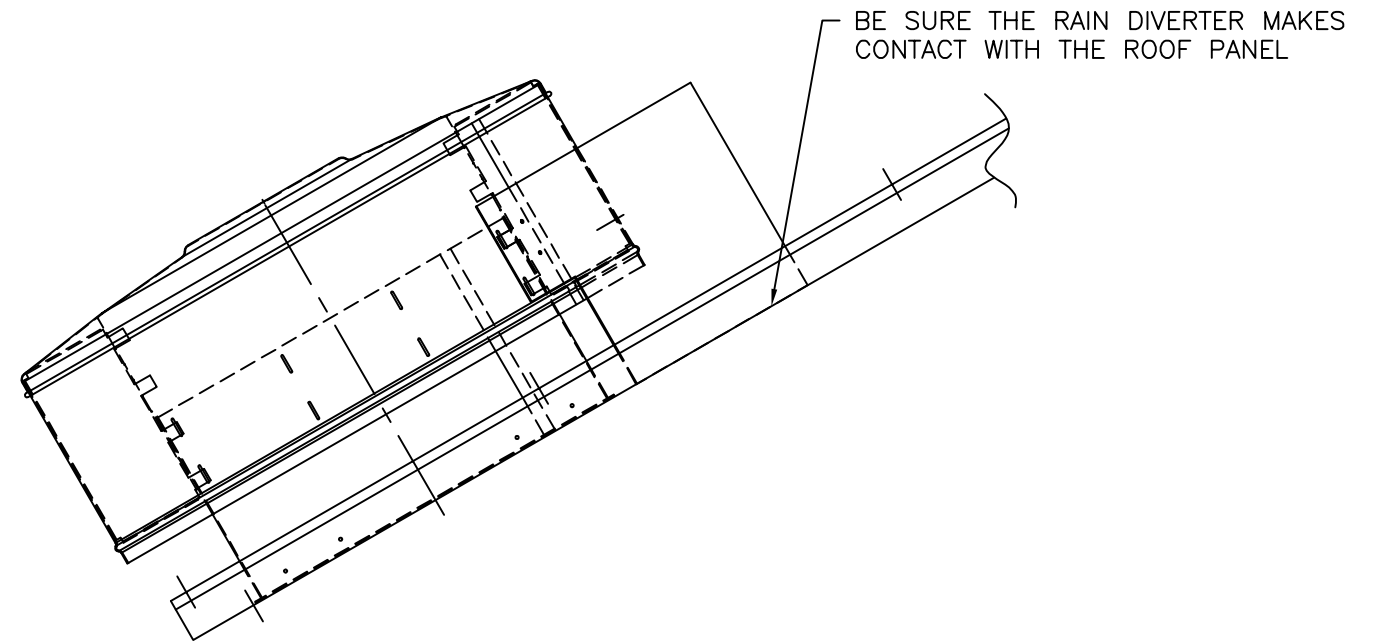

			MATERIAL:	BULLETIN 1250	FIN.WT.	X	DWG/PART NAME:			MANUAL,BIN VENT,MNBV-2.5,#1250,AGRI	
X	X	X	TOLERANCES UNLESS OTHERWISE SPECIFIED	FRACTIONS +- 1/32	DECIMALS +- .031	ANGLES +- 1/4	DIMENSIONS IN BRACKETS [] ARE METRIC EQUIVALENTS	THIS DRAWING AND ALL INFORMATION THEREON IS THE PROPERTY OF CHIEF INDUSTRIES INC., KEARNEY, NEBRASKA. IT IS LOANED CONFIDENTIALLY AND MUST NOT BE USED IN ANY WAY DETRIMENTAL TO CHIEF INDUSTRIES INC.			DWG/PART NO:
ECO NO.	BY	DATE	REVISIONS						DRAWN: KAM CHECKED: APPROVED:	BY: KAM DATE: 8/24/07 SIZE: B SCALE: 1/16"=1"	798207