

| | |
|-----------|---------|
| Part No. | 764266 |
| Bulletin | 1139 |
| Effective | 3/21/91 |

CALDWELL FULL ROUND SPIRAL CORRUGATED DUCT INSTALLATION INSTRUCTIONS

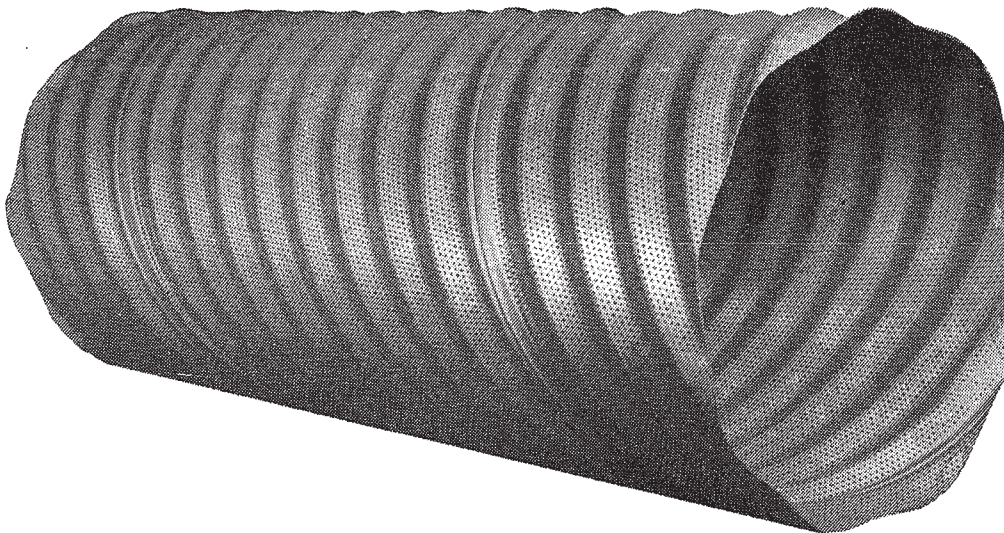

INTRODUCTION

THIS MANUAL PROVIDES INFORMATION ON THE INSTALLATION OF CALDWELL FULL ROUND SPIRAL CORRUGATED DUCT SYSTEMS. BEFORE INSTALLING THE CALDWELL AERATION SYSTEM, COMPLETELY READ THIS MANUAL. FOLLOWING THESE INSTRUCTIONS WILL RESULT IN THE SYSTEM BEING INSTALLED QUICKLY AND CORRECTLY.



A DIVISION OF CHIEF INDUSTRIES, INC.

MANUFACTURING COMPANY
POST OFFICE BOX 848
KEARNEY, NEBRASKA 68848

Phone

1-800-359-8833

In Nebraska Call 1-308-237-3186

To Our Valued Customer

The **Caldwell Manufacturing Company** products you have recently purchased have been engineered and manufactured to the highest possible standards. The product has been manufactured by caring and trustworthy individuals who live in the plains of Nebraska and have your best interests in mind.

With our total manufacturing effort in mind, if this product is installed according to this manual, we can assure you many years of trouble free service. Thank you for your confidence when purchasing a **Caldwell** product.

WARNING

The installation of the Spiral Corrugated Duct aeration system will require that a hole be provided for each duct run. **Contact the manufacturer of the structure for a recommendation on reinforcing the wall at each hole so that the wall maintains its structural integrity.** When installed to the Caldwell specifications the product is designed to support the grain loads present, **BUT NOT AS A REINFORCEMENT FOR THE WALL.**

⚠ WARNING

The installation of the Spiral Corrugated Duct aeration system will require that a hole in the grain structure be provided for each run and the components of the aeration system will require field fastening. For galvanized material to be cut with a cutting torch or to be welded the possibility of developing toxic fumes will exist. **Provide adequate ventilation and respiratory protection when using a cutting torch or welding on galvanized material.**

WARNING

Maximum grain depth recommendations are for static loads and for funnel flow unloading. **The recommendations on grain depths do not include loading provisions for the dynamic loads from frozen or bridging grain dropping suddenly on the duct or for the dynamic loads encountered in plug flow unloading.** Consult Caldwell Manufacturing for assistance in evaluating the duct requirements for plug flow unloading application.



TABLE OF CONTENTS

| | Page |
|--|-------|
| Table of Contents | 2 |
| List of Figures | 3 |
| I. Installation of Spiral Corrugated Duct on a Flat Surface | 4 |
| A. Installation of a Duct Run | 5 |
| Step 1. Elevation Check | 5 |
| Step 2. Hole Location for Wall Inlet Adaptor | 6 |
| Step 3. Mounting the Wall Inlet Adaptor | 7 |
| Step 4. Installation of the First Duct Piece | 7 |
| Step 5. Installation of the Succeeding Duct Pieces | 8 |
| Step 6. Installation of the Endcap | 8 |
| Step 7. Anchoring the Duct Run | 9 |
| II. Installation of Spiral Corrugated Duct on a Sloping Surface | 10 |
| A. Installation of a Duct Run | 12 |
| Step 1. Elevation Check | 12 |
| Step 2. Hole Location for Wall Adaptor | 12 |
| Step 3. Mounting the Wall Adaptor | 13-14 |
| Step 4. Installation of the First Duct Piece | 15 |
| Step 5. Installation of the Succeeding Duct Pieces | 15 |
| Step 6. Installation of the Endcap | 16 |
| Step 7. Anchoring of the Saddle Tiedowns | 16 |
| Step 8. Installation of the Retainer Angle | 16 |
| III. Summary | 17 |
| Appendix A: | |
| Maximum Grain Depths for Full Round Spiral Corrugated Duct | 18 |
| Warranty/Service Policy | 19 |



LIST OF FIGURES

| | Page |
|---|------|
| Figure 1. Typical Parts Used for Assembly on a Flat Surface | 5 |
| Figure 2. Typical Duct Elevation | 5 |
| Figure 3. Determine the Hole Diameter for the Building Wall | 6 |
| Figure 4. Placement of the Hole in the Wall | 6 |
| Figure 5. Determine the Hole Diameter for the Stem Wall | 6 |
| Figure 6. Mounting the Wall Adaptor | 7 |
| Figure 7. Mounting the 14" Wall Adaptor | 7 |
| Figure 8. Installation of the First Duct Piece | 7 |
| Figure 9. Installation of a Clampband | 8 |
| Figure 10. Installation of the Endcap | 8 |
| Figure 11. Installation of a Tiedown Strap | 9 |
| Figure 12. Routing of the Strap through the Buckle | 9 |
| Figure 13. Typical Parts Used for Assembly on Sloping Surfaces | 11 |
| Figure 14. Typical Duct Elevation with an Elbow | 12 |
| Figure 15. Typical Duct Elevation with an Offset Adaptor and Elbow | 12 |
| Figure 16. Elbow Adaptor Placement | 13 |
| Figure 17. Offset Adaptor and Elbow Adaptor Placement | 13 |
| Figure 18. Wall Adaptor and Elbow Placement | 14 |
| Figure 19. Mounting the Wall Adaptor | 14 |
| Figure 20. Mounting the 14" Wall Adaptor | 14 |
| Figure 21. Offset Adaptor and Elbow Adaptor Placement with the Wall Adaptor | 14 |
| Figure 22. Installation of the First Duct Piece | 15 |
| Figure 23. Installation of a Clampboard | 15 |
| Figure 24. Installation of a Saddle Tiedown | 15 |
| Figure 25. Installation of the Endcap | 16 |
| Figure 26. Installation of the Retainer Angle | 16 |

I) INSTALLATION OF SPIRAL CORRUGATED DUCT ON A FLAT SURFACE

Prior to starting the installation of the **Caldwell Spiral Corrugated Duct** on a flat surface, refer to **Figure 1** on **page 5**, and make sure you have the necessary components present and in the correct quantities for your installation. Also refer to **Appendix A** on **page 18** for information on the maximum grain depths allowed for the particular duct diameter and gauge of material. **WARNING: Do not install duct in grain depths greater than what is specified in Appendix A. NOTE, that recommendations on maximum grain depths are for funnel flow unloading only. The recommendations on grain depths do not include loading provisions for the dynamic loads from frozen or bridging grain dropping suddenly on the duct or for the dynamic loads encountered in plug flow unloading.** Consult Caldwell Manufacturing for assistance in evaluating the duct requirements for plug flow unloading applications.

A typical installation utilizes the following components for each run:

| <u>Quantity</u> | <u>Component</u> |
|-----------------|------------------------------------|
| one | Wall Adaptor for Corrugated Duct |
| one | Sealing Angle Ring for Spiral Duct |
| a | Solid Spiral Corrugated Duct |
| b | Perforated Spiral Corrugated Duct |
| (a+b-1) | Clampband Assembly for Spiral Duct |
| | (Per Clampband Assembly) |
| | 1 Clampband |
| | 4 5/16" full thread Capscrews |
| | 4 5/16" Nuts |
| c | Tiedown Strap |
| one | Endcap |

where:

- a = quantity of Solid Duct pieces (pieces can be of various lengths)
- b = quantity of Perforated Duct pieces (pieces can be of various lengths)
- c = quantity of Tiedown Straps (approx. 1 per 30' of run)



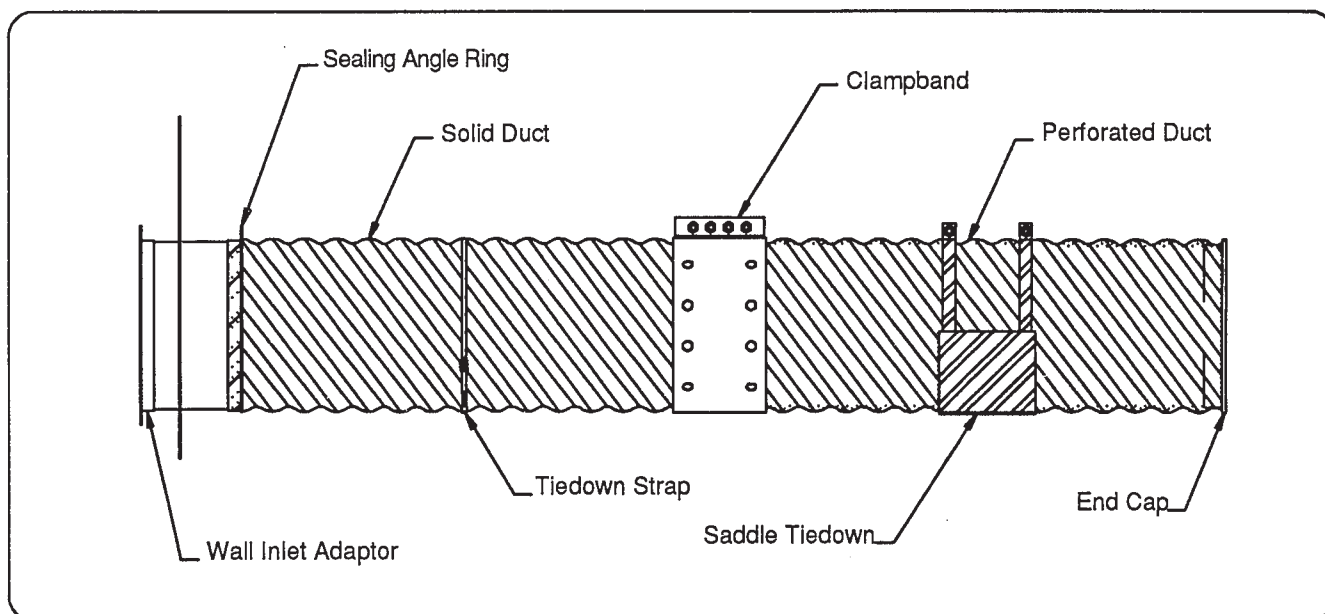

Figure 1. Typical Parts Used for Assembly on a Flat Surface.

A) INSTALLATION OF DUCT RUN

Once the quantity of components for your system are present, determine the location of the various duct runs for proper aeration. **Make sure the runs avoid interference with the wall structural components.** When the duct run locations have been determined, then install each duct run according to the following steps:

Step 1: Elevation Check

The Annular Corrugated Duct should be supported directly on the floor when installed. Therefore the bottom of the Wall Inlet Adaptor tube should be located approximately 3/4" above the floor. When the Wall Inlet Adaptor is installed, the fan pad will typically be lower than the floor. See **Figure 2**. Determine the fan pad elevation for your installation by checking the position of the fan when installed. (Refer to the fan manual for your fan pad elevation.)

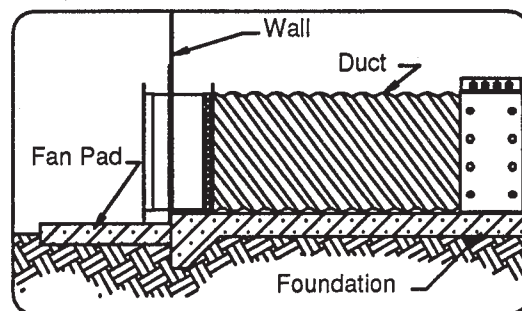

Figure 2. Typical Duct Elevation

Step 2: Hole Location for Wall Inlet Adaptor

a. Hole Location for Structural Building Wall.

The hole for the Wall Inlet Adaptor needs to be cut into the structure, such that the hole is approximately 1/2" larger in diameter than the end of the Wall Inlet Adaptor opposite the angle flange. See **Figure 3**. The bottom of the hole should be approximately 1/2" above the floor. See **Figure 4**. Once the hole has been cut, position the Wall Inlet Adaptor in the hole and make sure the square wall flange of the Wall Inlet Adaptor can be positioned up to the wall. Reinforce the wall around the hole to the specifications of the storage structure manufacturer to make sure the wall maintains its structural integrity. Refer to the **Warning on page 1 on structural integrity**. In addition, when cutting galvanized material with a torch refer to the **Warning on toxic fumes on page 1**. The square wall flange on the Wall Inlet Adaptor is designed to aid in sealing the installation, not to reinforce the wall.

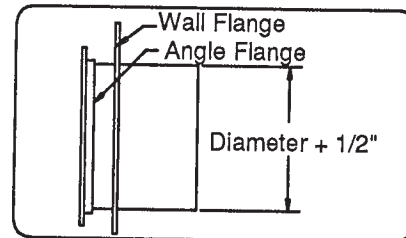

Figure 3. Determine Hole Diameter for Building Wall

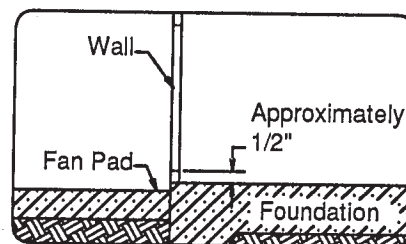

Figure 4. Placement of Hole in Wall

b. Hole Location for Concrete Stem Wall

Use a construction ring approximately 1" larger in diameter than the Wall Inlet Adaptor, at the square wall flange, to form the hole or partial hole. See **Figure 5**. Locate the bottom of the construction ring approximately 1/4" above the floor. Make sure the construction ring is constructed and supported to generate a round hole when the concrete stem wall is complete.

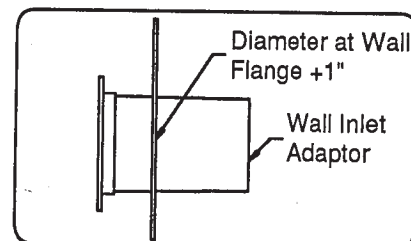

Figure 5. Determine Hole Diameter for Stem Wall

Step 3. Mounting Wall Inlet Adaptor

The Wall Inlet Adaptor is now installed into the opening defined in Step 2. The Wall Inlet Adaptor is positioned such that the bottom of the square wall flange is parallel to grade, which results in a mounting hole on the round angle flange being positioned at the top of the adaptor. See **Figure 6.** (**Except: on the 14" Wall Inlet Adaptor, the mounting holes will fall on a 45 degree angle to the wall flange.** See **Figure 7.**) Secure the square wall flange to the wall by either bolting or welding the square wall flange to the wall. **Refer to the Warning on Page 1 when welding galvanized material. Seal** the square wall flange to the wall to eliminate air leaking out or moisture leaking in.

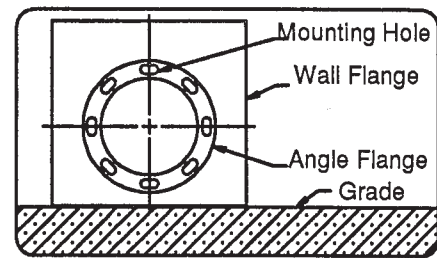

Figure 6. Mounting Wall Adaptor

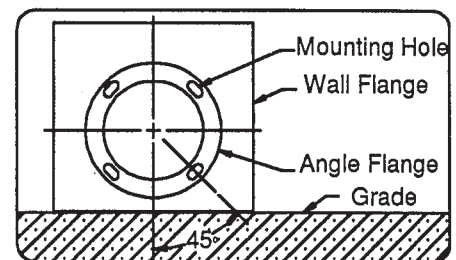

Figure 7. Mounting 14" Wall Adaptor

Step 4. Installation of First Duct Piece

The installation of the first duct requires 2 components, the Sealing Angle Ring and the first Spiral Corrugated Duct piece. Depending on the application, the first duct piece could be perforated or solid, but is most likely to solid.

Position the Sealing Angle Ring over the Wall Inlet Adaptor and slide the Sealing Angle up to the wall. As illustrated in **Figure 8,** the vertical leg of the Sealing Angle is positioned toward the duct with the flat section of the Sealing Angle Ring at the floor. **The Sealing Angle Ring is not anchored at this time.**

The Spiral Corrugated Duct is slid over the Wall Inlet Adaptor and up to the Sealing Angle Ring. See **Figure 8.** The Spiral Corrugated Duct should extend at least 3" onto the adaptor. Weld the Spiral Corrugated Duct to the Wall Inlet Adaptor. Then slide the Sealing Angle Ring up to the secured duct and make sure the duct is sealed such that grain cannot enter the duct at the Sealing Angle Ring. Weld the Sealing Angle Ring in position. **Refer to the Warning on Page 1 when welding galvanized material.**

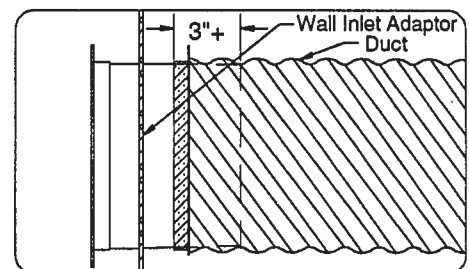

Figure 8. Installation of First Duct Piece

Step 5. Installation of Succeeding Duct Pieces

Install the succeeding Spiral Corrugated Duct pieces one at a time by means of a Clampband Assembly. The Clampband has dimples positioned, such that for the particular diameter of duct being installed, a dimple will seal into the valley of each corrugation on the spiral duct.

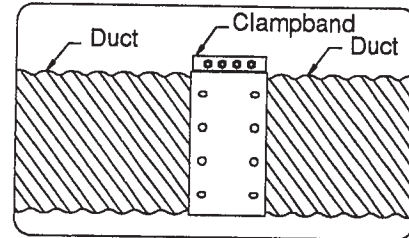

Figure 9. Installation of a Clampband

Position the Clampband on the end of the previously installed duct, such that: the Clampband is one half way under the duct; is located with the dimples matching the valleys; and the Clampband securing clips will be near the top of the duct. **See Figure 9.** Slide the next spiral duct piece up to the end of the previously secured duct piece. Rotate the duct piece so that the valleys of the corrugations will be centered on the dimples of the Clampband. **See Figure 9.** Pull the Clampband up around the duct pieces. A C-clamp vise-grip may be useful in pulling the Clampband clips together. Now secure the Clampband by using the 4 capscrews and nuts provided. Tighten the Clampband by drawing up each bolt slightly and then continuing to the next bolt. The sequence of tightening is followed until the Clampband seals tightly to the Spiral Corrugated Duct pieces. **Do not exceed a torque value of 240 inch pounds in tightening the bolts.** Continue to install the succeeding duct pieces in the same manner.

Step 6. Installation of Endcap

Install the Endcap onto the last Spiral Corrugated Duct piece. The Endcap slides into the duct piece so that the plate of the Endcap is centered on the duct. **See Figure 10.** With the Endcap properly positioned on the duct, secure the Endcap in place by welding to the duct. Refer to the Warning on page 1 when welding galvanized material. **Make sure the corrugations are sealed so grain can not enter the duct.**

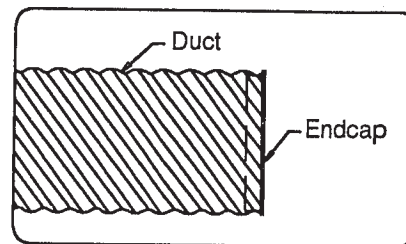

Figure 10. Installation of Endcap

Step 7. Anchoring the Duct Run

The duct run should be secured to the floor at approximate 30' increments. Fastening to the floor eliminates the potential lateral movement of the duct encountered during filling. The Tiedown Straps should be positioned approximately on 30' increments and no more than 10' from the end of the duct run. For applications where the grain filling procedure will result in the grain flowing up to one side of the duct only, the Tiedown Straps should be located on 10' increments. Secure the Tiedown Strap anchor clips to the floor such that the clip is aligned tangent to the side of the duct. See **Figure 11**. For a concrete floor use a wedging type anchor bolt (not provided). The anchor bolt should be sized at a minimum of 1/2" diameter. Now tighten the fabric strap around the duct by routing the strap through the buckle as shown in **Figure 12**. Then cinch the strap tight.

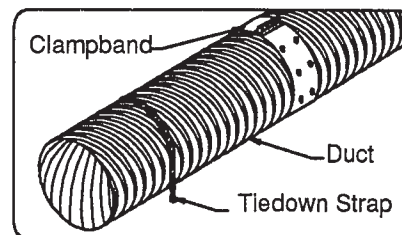

Figure 11. Installation of a Tiedown Strap

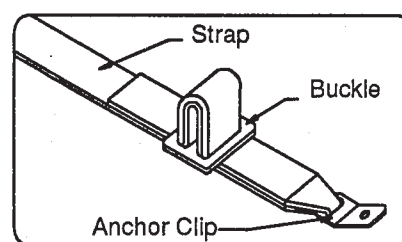

Figure 12. Routing of the Strap through the Buckle

Installation of the **Caldwell Spiral Corrugated Duct** run is now complete. Install the remaining duct runs in the same manner. After all the runs are installed, clean and repaint areas where field welding was utilized to provide corrosion protection.

II) INSTALLATION OF SPIRAL CORRUGATED DUCT ON A SLOPING SURFACE

Caldwell Spiral Corrugated Duct can be used in above ground or below ground hopper bottom tanks with steel or concrete floors. Prior to starting the installation of the Spiral Corrugated Duct on a sloping surface, refer to **Figure 13** on **page 11**, and make sure you have the necessary components present and in the correct quantities for your installation. Also refer to **Appendix A** on **page 18** for information on the maximum grain depths allowed for a particular duct diameter and gauge of material. **WARNING: Do not install duct in grain depths greater than what is specified on Appendix A.** **NOTE, that recommendations on maximum grain depths are for funnel flow unloading only. The recommendations on grain depths do not include loading provisions for the dynamic loads from frozen or bridging grain dropping on the duct or for the dynamic loads encountered in plug flow unloading.** Consult Caldwell Manufacturing for assistance in evaluating the duct requirements for plug flow unloading applications. A typical installation utilizes the following components for each run:

| <u>Quantity</u> | <u>Component</u> |
|-----------------|--|
| one* | Wall Adaptor for Corrugated Duct |
| a | Solid Spiral Corrugated Duct with rerolled ends |
| b | Perforated Spiral Corrugated Duct with rerolled ends |
| one | Retainer Angle |
| (a+b-1) | Clampband Assembly for Annular Corrugated Duct (Per Clampband Assembly) |
| | 1 Clampband |
| | 4 5/16" Full Thread Capscrews |
| | 4 5/16" Nuts |
| c | Saddle Tiedown Assembly for Spiral Duct (Per Tiedown Assembly) |
| | 1 Tiedown |
| | 2 5/16" Capscrews |
| | 2 5/16" Nuts |
| one | Endcap Assembly for Spiral Duct |

where:

a = quantity of Solid Duct pieces (pieces can be various lengths)

b = quantity of Perforated Duct pieces (pieces can be various lengths)

c = quantity of Saddle Tiedowns (approx. 1 per 20')

*NOTE: Wall Adaptor may be multiple parts consisting of:

Elbow

or Elbow and Wall Adaptor

or Elbow and Offset Adaptor

or Elbow, Wall Adaptor, and Offset Adaptor



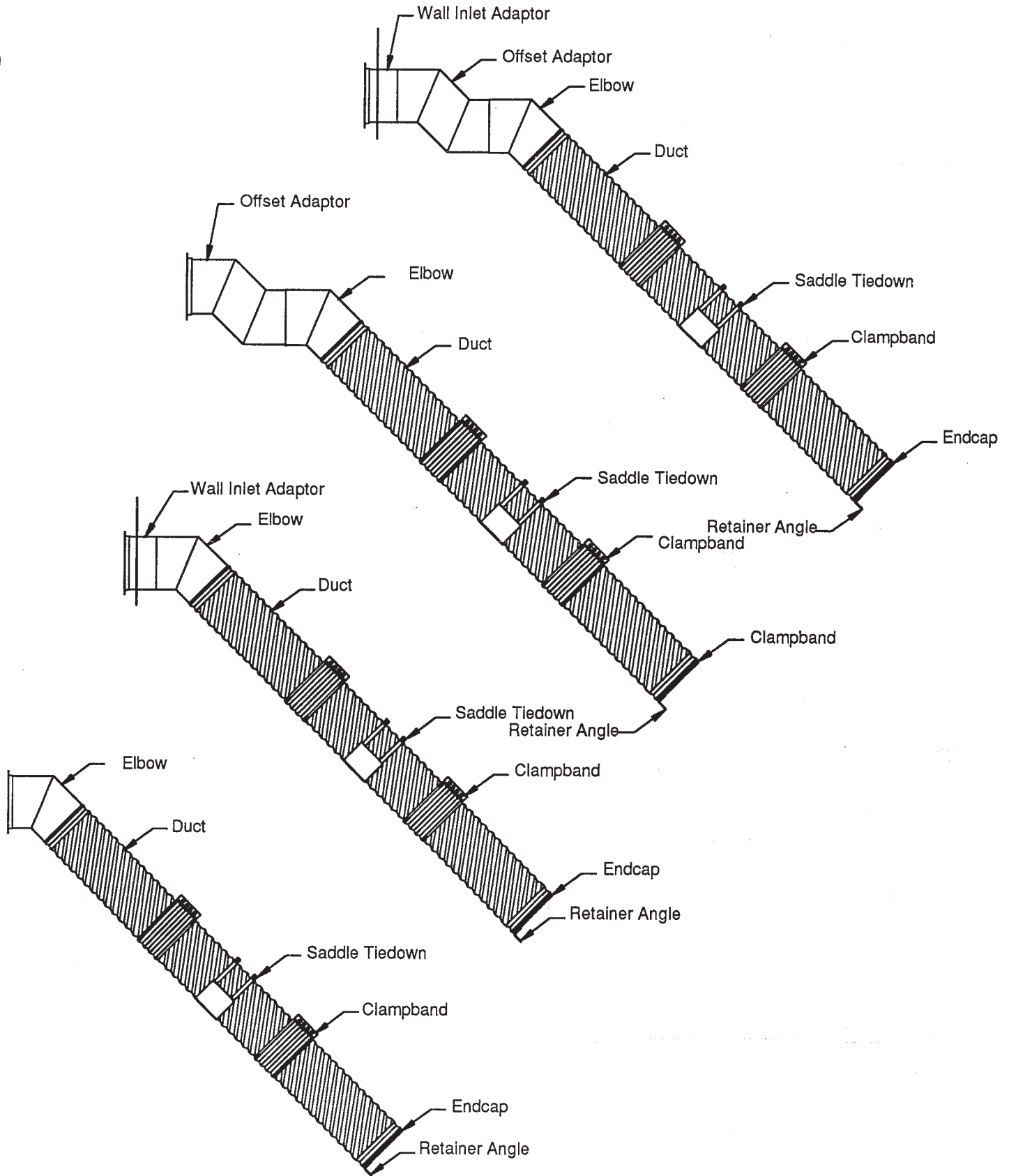

Figure 13. Typical Parts Used for Assembly on Sloping Surfaces

Step 3. Mounting Wall Adaptor

a. Elbow Adaptor

Slide one leg of the Adaptor through the wall from the inside of the structure to the outside. Temporarily position the first Corrugated Duct piece over the other leg of the Elbow Adaptor to establish the final position of the Elbow Adaptor. See **Figure 16**. Slide the mounting Angle Ring over the leg of the Elbow Adaptor outside the structure, such that the vertical leg of the Angle Ring is flush with the end of the elbow. See **Figure 16**. Weld the Elbow Adaptor to the wall, welding continuously and **then make sure the mounting holes on the Angle Ring are positioned to match the fan and weld the Angle Ring to the Elbow Adaptor. Refer to the Warning on page 1 when welding galvanized material. Be sure the wall is sealed to prevent air from leaking out and water from leaking in.**

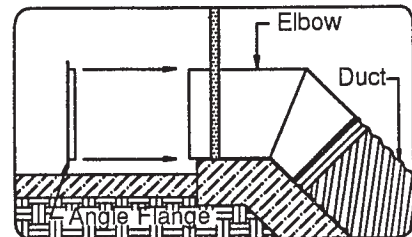

Figure 16. Elbow Adaptor Placement

b. Offset Elbow Adaptor

Slide one leg of the Offset Elbow Adaptor through the wall from the inside of the structure to the outside. Temporarily position the Elbow Adaptor over the leg of the Offset Elbow Adaptor, which is inside the structure, and place the first piece of duct over the last leg of the Elbow Adaptor that starts down the slope of the hopper, as illustrated in **Figure 17**. This is done to establish the final position of the Offset Elbow Adaptor. Slide the mounting Angle Ring over the end of the Offset Elbow Adaptor outside the structure, such that the vertical leg of the Angle Ring is flush with the end of the Elbow. See **Figure 17**. Weld the Offset Elbow Adaptor to the wall, welding continuously and **make sure the mounting holes on the Angle Ring are positioned to match the fan and then weld the Angle Ring to the Offset Elbow Adaptor. Refer to the Warning on page 1 when welding galvanized material. Be sure the wall is sealed to prevent air from leaking out and water from leaking in.** The remaining work on the inlet assembly will be done inside the structure. Weld the Elbow Adaptor to the Offset Elbow Adaptor.

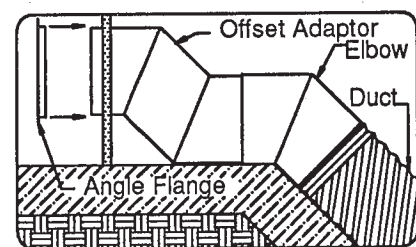

Figure 17. Offset Elbow Adaptor and Elbow Adaptor Placement

Step 3. Mounting Wall Adaptor

a. Elbow Adaptor

Slide one leg of the Adaptor through the wall from the inside of the structure to the outside. Temporarily position the first Corrugated Duct piece over the other leg of the Elbow Adaptor to establish the final position of the Elbow Adaptor. See **Figure 16**. Slide the mounting Angle Ring over the leg of the Elbow Adaptor outside the structure, such that the vertical leg of the Angle Ring is flush with the end of the elbow. See **Figure 16**. Weld the Elbow Adaptor to the wall, welding continuously and **then make sure the mounting holes on the Angle Ring are positioned to match the fan** and weld the Angle Ring to the Elbow Adaptor. **Refer to the Warning on page 1 when welding galvanized material. Be sure the wall is sealed to prevent air from leaking out and water from leaking in.**

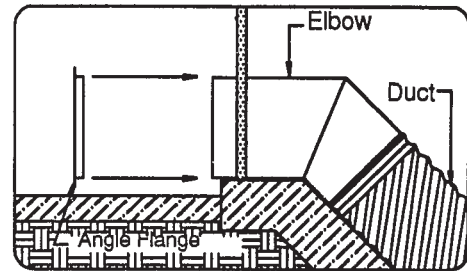

Figure 16. Elbow Adaptor Placement

b. Offset Elbow Adaptor

Slide one leg of the Offset Elbow Adaptor through the wall from the inside of the structure to the outside. Temporarily position the Elbow Adaptor over the leg of the Offset Elbow Adaptor, which is inside the structure, and place the first piece of duct over the last leg of the Elbow Adaptor that starts down the slope of the hopper, as illustrated in **Figure 17**. This is done to establish the final position of the Offset Elbow Adaptor. Slide the mounting Angle Ring over the end of the Offset Elbow Adaptor outside the structure, such that the vertical leg of the Angle Ring is flush with the end of the Elbow. See **Figure 17**. Weld the Offset Elbow Adaptor to the wall, welding continuously and **make sure the mounting holes on the Angle Ring are positioned to match the fan** and then weld the Angle Ring to the Offset Elbow Adaptor. **Refer to the Warning on page 1 when welding galvanized material. Be sure the wall is sealed to prevent air from leaking out and water from leaking in.** The remaining work on the inlet assembly will be done inside the structure. Weld the Elbow Adaptor to the Offset Elbow Adaptor.

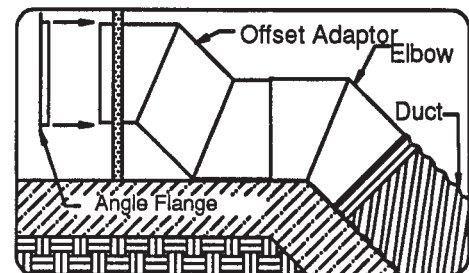

Figure 17. Offset Elbow Adaptor and Elbow Adaptor Placement

c. Straight Wall Adaptor Used With Elbow Adaptor

Slide the tube of the Wall Adaptor through the wall from the outside of the structure to the inside. See **Figure 18**. The Wall Adaptor is positioned such that the bottom of the square wall flange is parallel to the grade which results in a mounting hole on the round Angle Flange being positioned at the top of the adaptor. See **Figure 19**. (Except: on the 14" Wall Adaptor, the mounting holes will fall on a 45 degree angle to the wall flange. See **Figure 20**.) Secure Wall Adaptor to the wall by welding the square wall flange and tube to the wall to eliminate air leaking out or moisture leaking in. **Refer to the Warning on Page 1 when welding galvanized material.**

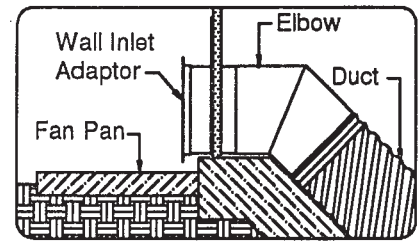

Figure 18. Wall Adaptor and Elbow

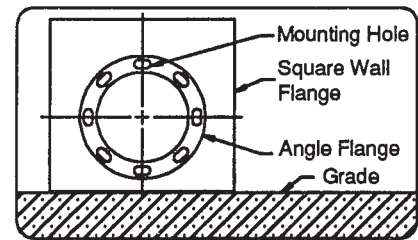

Figure 19. Mounting Wall Adaptor

The Elbow Adaptor is now slid over the Wall Adaptor as far as possible. Temporarily position the first spiral duct piece over the other leg of the Elbow Adaptor to establish the final position of the Elbow Adaptor. See **Figure 18**. The Elbow Adaptor is welded continuously to the Wall Adaptor. **Refer to the Warning on Page 1 when welding galvanized material.**

d. Straight Wall Adaptor Used With Offset Elbow Adaptor

Slide the tube of the Wall Adaptor through the wall from the outside of the structure to the inside. See **Figure 21**. The Wall Adaptor is positioned such that the bottom of the square wall flange is parallel to the grade which results in a mounting hole on the round Angle Flange being positioned at the top of the Adaptor. See **Figure 19**. (Except: on the 14" Wall Adaptor, the mounting holes will fall on a 45 degree angle to the wall flange. See **Figure 20**.) Secure the Wall Adaptor to the wall by welding the square wall flange and tube to the wall to eliminate air leaking out or moisture leaking in. **Refer to the Warning on page 1 when welding galvanized material.**

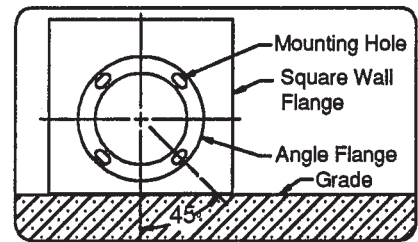

Figure 20. Mounting the 14" Wall Adaptor

The Offset Elbow Adaptor is now slid over the Wall Inlet Adaptor as far as possible, as illustrated in **Figure 21**. Temporarily position the Elbow Adaptor over the other leg of the Offset Adaptor. Position the first corrugated duct piece over the leg of the Elbow Adaptor that starts down the slope of the hopper, to establish the final position of the Offset Elbow Adaptor. Weld the Offset Elbow Adaptor continuously to the Wall Adaptor continuously to the Wall Adaptor. Next, the Elbow Adaptor is secured to the Offset Elbow Adaptor by welding continuously. **Refer to the Warning on page 1 when welding galvanized material.**

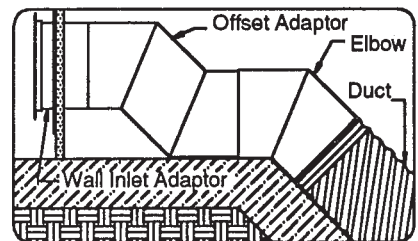

Figure 21. Offset Adaptor and Elbow Adaptor Placement with Wall Adaptor

Step 4. Installation of First Duct Piece

Install the first piece of Duct to the Elbow Adaptor by sliding the Duct over the leg of the adaptor going down the slope of the hopper. See **Figure 22**. Depending on the application the first duct piece could be perforated or solid but is most likely to be solid. The Duct should be slid as far as possible onto the Elbow adaptor (at least 3"). Now, weld the Spiral Corrugated Duct to the adaptor. **Refer to the Warning on Page 1 when welding galvanized material.** Make sure the adaptor is sealed to the Spiral Corrugated Duct such that grain cannot enter the duct.

Step 5. Installation of Succeeding Duct Pieces

Install the succeeding Spiral Duct pieces one at a time by means of a Spiral Clampband Assembly. Remember to position a Saddle Tiedown on the Spiral Duct such that a Saddle Tiedown will be located on approximately 20' centers. Hand tighten the two 5/16" bolts and nuts provided for the Tiedown Straps. See **Figure 24**. Slide the Spiral Clampband over the previously installed duct such that the Clampband overlaps 2 corrugations. See **Figure 23**. Slide the next Spiral Corrugated Duct piece into the Clampband such that the Clampband overlaps the duct by 2 corrugations. The corrugations of the Clampband should nest onto the corrugations of the two rerolled ends of the pieces as illustrated in **Figure 23**. A C-clamp vise-grip may be useful in pulling the Clampband clips together. Now, secure the Clampband by using the 4 capscrews and nuts provided. Tighten the Clampband bolts by drawing up each bolt slightly and then continuing to the next bolt. The sequence of tightening is followed until the band seals tightly to the Annular corrugation of the Spiral Duct pieces. **Do not exceed a torque value of 240 inch pounds in tightening the bolts.** Continue to install succeeding Duct pieces in the same manner. **Do not secure the Saddle Tiedown until the entire Duct run is assembled.**

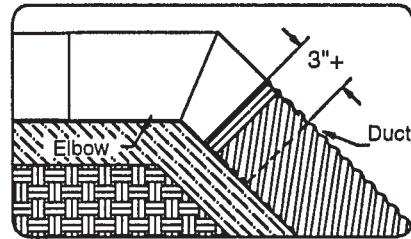

Figure 22. Installation of First Duct Piece

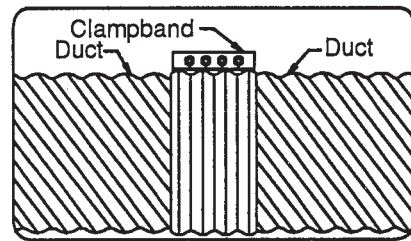

Figure 23. Installation of Clampband

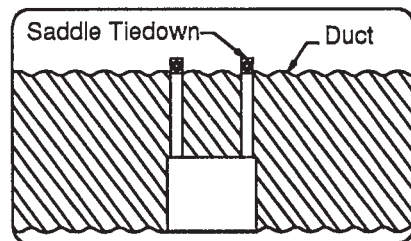

Figure 24. Installation of Saddle Tiedown

Step 6. Installation of Endcap

Install the Endcap onto the last Spiral Corrugated Duct piece. The Endcap slides into the duct piece so that the plate of the Endcap is centered on the duct. See **Figure 25**. With the Endcap properly positioned on the duct, secure the Endcap in place by welding to the duct. Refer to the **Warning on page 1** when welding galvanized material. Make sure the corrugations are sealed so grain can not enter the duct.

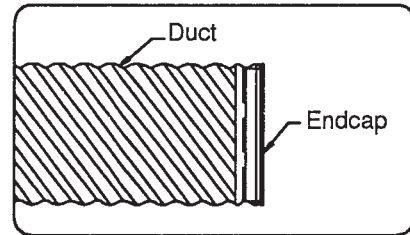

Figure 25. Installation of Encap

Step 7. Anchoring of Saddle Tiedowns

The duct run is secured to the floor by means of the previously positioned Saddle Tiedowns. Make sure the legs of the Saddle Tiedowns are located at the floor and then tighten the Saddle Tiedown straps. Secure the Saddle Tiedown legs to the floor. See **Figure 23 on page 15**. For a concrete floor, use a wedging type anchor bolt (not provided). The anchor bolts should be sized at a minimum of 1/2" diameter.

Step 8. Installation of Retainer Angle

The Retainer Angle is installed at the end of the Duct run to assist in preventing the Duct from sliding down the hopper. With the Endcap already installed, center the Retainer Angle on the duct run, and push the Retainer Angle up against the Duct. See **Figure 26**. Secure the Retainer Angle to the floor. For a concrete floor, use wedging type anchor bolts (not provided). The anchor bolts should be sized at minimum of 1/2" diameter.

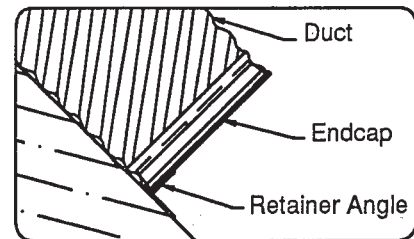

Figure 26. Installation of the Retainer Angle

Installation of the **Caldwell Spiral Corrugated Duct** run on a sloping surface is now complete. Install the remaining duct runs in the same manner. After all the runs are installed, clean and repaint areas where field welding was utilized to provide corrosion protection.

III. SUMMARY

The preceding Spiral Corrugated Duct instructions provide the necessary directions on the installation of the **Caldwell** full round **Spiral Duct System**. The most important factors in making sure the aeration duct system will function properly are that the duct is rated to handle the loads for the grain depth present and that the duct and adaptors are fully supported.

Nearly every installation is unique in some manner. The instructions provided for each basic component will provide the necessary criteria for proper installations. However, if you feel that your Spiral Corrugated Duct installation is not covered by the installation instructions contact **Caldwell Manufacturing Company** for assistance.

When contacting the factory for assistance, ask for the Customer Service Department. Provide the geometric details of the installation and a listing of Spiral Corrugated Duct parts intended to be used. The Customer Service Department will be able to advise you with instructions for installation of the Spiral Corrugated Duct components for your installation.



**APPENDIX A: MAXIMUM GRAIN DEPTHS
FOR FULL ROUND SPIRAL CORRUGATED DUCT**

| Diameter | Gauge of Material | Color Code | Maximum Application Grain Depth in Feet |
|----------|-------------------|------------|---|
| 12" | 20 | White | 130' |
| 12" | 18 | Orange | 165' |
| 14" | 20 | White | 100' |
| 14" | 18 | Orange | 145' |
| 16" | 20 | White | 60' |
| 16" | 18 | Orange | 85' |
| 16" | 16 | Green | 115' |
| 16" | 14 | Yellow | 150' |
| 18" | 20 | White | 45' |
| 18" | 18 | Orange | 65' |
| 18" | 16 | Green | 105' |
| 18" | 14 | Yellow | 130' |
| 18" | 12 | Blue | 190' |
| 21" | 18 | Orange | 55' |
| 21" | 16 | Green | 75' |
| 21" | 14 | Yellow | 100' |
| 21" | 12 | Blue | 130' |
| 24" | 18 | Orange | 40' |
| 24" | 16 | Green | 60' |
| 24" | 14 | Yellow | 75' |
| 24" | 12 | Blue | 95' |

NOTE: A) Application Grain Depth is the greatest grain depth in a structure. For flat storage structures, the grain depth is from floor to the grain peak. For hopper bottom tank applications, the grain depth is from the very base of the hopper to the grain peak.

B) The table illustrates maximum grain depths for normal grain loads. Grain weight of 48 pounds per cubic foot or less.

WARNING

Maximum grain depth recommendations are for static loads and for funnel flow unloading. The recommendations on grain depths do not include loading provisions for the dynamic loads from frozen or bridging grain dropping suddenly on the duct or for the dynamic loads encountered in plug flow unloading. Consult Caldwell Manufacturing for assistance in evaluating the duct requirements for plug flow unloading applications.



PRODUCT SERVICE: Our top priority is to assure customer satisfaction on all Caldwell products. If a dealer requires assistance from Caldwell, contact our Service Department. The dealer purchasing a product from Caldwell Manufacturing Company will be responsible for the installation, operation, service, in accordance with Caldwell Manufacturing Company Service Policy. The dealer will also be responsible for all Standard Limited Warranty procedures in accordance with Caldwell Manufacturing Company.

SERVICE POLICY

CALDWELL STANDARD LIMITED WARRANTY: DEALERS HAVE THE RESPONSIBILITY OF CALLING TO THE ATTENTION OF THEIR CUSTOMERS THE FOLLOWING LIMITED WARRANTY, PRIOR TO ACCEPTANCE OF AN ORDER FROM THE CUSTOMER FOR ANY CALDWELL MANUFACTURING COMPANY PRODUCTS.

Caldwell Manufacturing Company warrants to the purchaser for use that if any part of the product is proven to be defective in material or workmanship with **2 years** from date of original invoice from factory, and Caldwell Manufacturing Company is notified within 15 days after such defect is discovered, Caldwell Manufacturing Company, will (at company option) either replace or repair said part. This standard limited warranty does not apply to damage resulting from misuse, neglect, material wear, accident or improper installation or maintenance. Said part will not be considered defective if it substantially fulfills performance specifications. **THE FOREGOING LIMITED WARRANTY IS EXCLUSIVE AND IN LIEU OF ALL OTHER WARRANTIES OF MERCHANTABILITY, FITNESS FOR PURPOSE AND OF ANY OTHER TYPE, WHETHER EXPRESSED OR IMPLIED.** Caldwell Manufacturing Company neither assumes nor authorizes anyone to assume for it any other obligation or liability in connection with said part and will not be liable for incidental or consequential damages. **THE REMEDIES STATED HEREIN SHALL BE THE EXCLUSIVE REMEDIES AVAILABLE UNDER THIS STANDARD LIMITED WARRANTY. CLAIMS UNDER THIS STANDARD LIMITED WARRANTY SHALL BE HANDLED UNDER THE STANDARD SERVICE POLICY.** Caldwell Manufacturing Company will not be responsible for any charges incurred in repairing or servicing any Caldwell products except as such repairs are made at Caldwell or by Caldwell Field Service Personnel or as approved in writing from Caldwell Customer Service.

IN WARRANTY REPLACEMENT: The Caldwell Manufacturing Company Standard Limited Warranty Policy will cover any defective part of the product covered by the Standard Limited Warranty. Equipment involved in a warranty claim under the above Standard Limited Warranty shall have the ORIGINAL WARRANTY REGISTRATION CARD on file in Kearney, Nebraska, and have been properly installed, maintained and operated according to the instructions provided by Caldwell Manufacturing Company.

WARRANTY CLAIM PROCEDURES: When a part failure occurs, that in your judgement meets the conditions of the above Standard Limited Warranty, contact your dealer to make arrangements for the shipment of a replacement item and the return of the defective equipment.

ELECTRIC MOTOR WARRANTY: The Manufacturers of all electric motors used by Caldwell Manufacturing Company carry a warranty for these items. If the motor fails under the conditions of Caldwell Manufacturing Company Standard Limited Warranty Policy, and provided it was protected by the proper protective device, the motor manufacturer's nearest authorized service center will repair it. See catalog for motor manufacturers service centers. Any in warranty replacement motors not satisfactorily handled by motor manufacturer service centers and within the Standard Limited Warranty period and policy will be covered by Caldwell Manufacturing Company, Kearney, Nebraska. Contact Caldwell if you have any problems or questions.

OUT OF WARRANTY SERVICE: Products requiring Caldwell Manufacturing Company repair work will be repaired at the standard repair charge plus hourly charges after the first hour. Field service work will require a field service charge plus travel expenses. The repaired part will carry a 30 day limited warranty.

Your dealer will be responsible for warranty procedures in accordance with Caldwell Manufacturing. (See Dealer Policy.)



NOTES