

C18 / C30 / C33 / C36 RAIN HOOD INSTALLATION

The rain hood has been manufactured and shipped in an unassembled condition. All the brackets and fasteners required to install the rain hood are included in this bulletin #1161.

Note: When installing or servicing electrical components, always lock out and tag out electrical power at the fan disconnect.

To install:

1. Locate the right angle brackets to the outside of the rain hood and loosely attach the right angle brackets to the rain hood surface at the location of each pair of 11/32" (.87cm) holes. Note that the vertical leg of each bracket should be closest to the end of the rain hood. The support strap will be located on the inside of the rainhood.

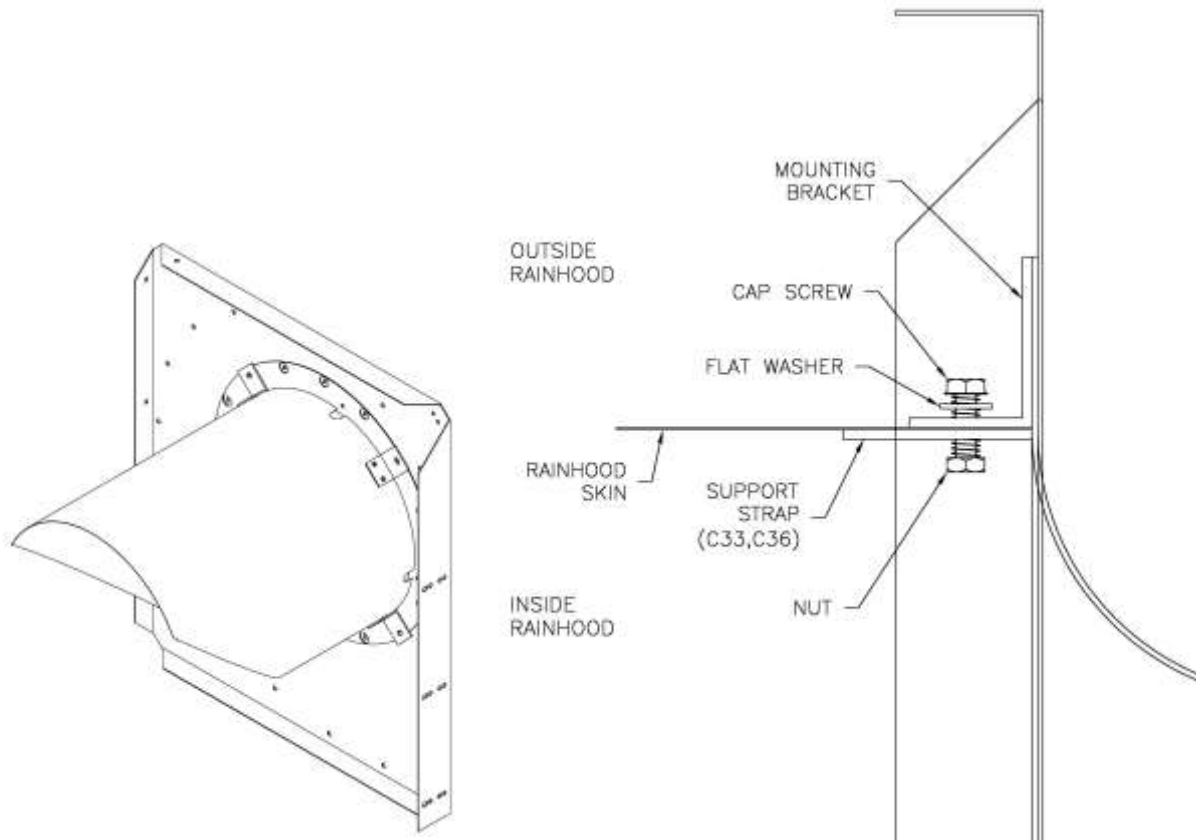

2. Attach the rain hood to the inlet orifice.
 - a. Overlap will be located at the bottom of orifice. Remove the bolts and washers from the inlet orifice, which correspond to the brackets installed on the rain hood.
 - b. Align rain hood bracket holes with the orifice holes, and reinstall bolts and washers tightly.
 - c. Tighten all cap screws completely

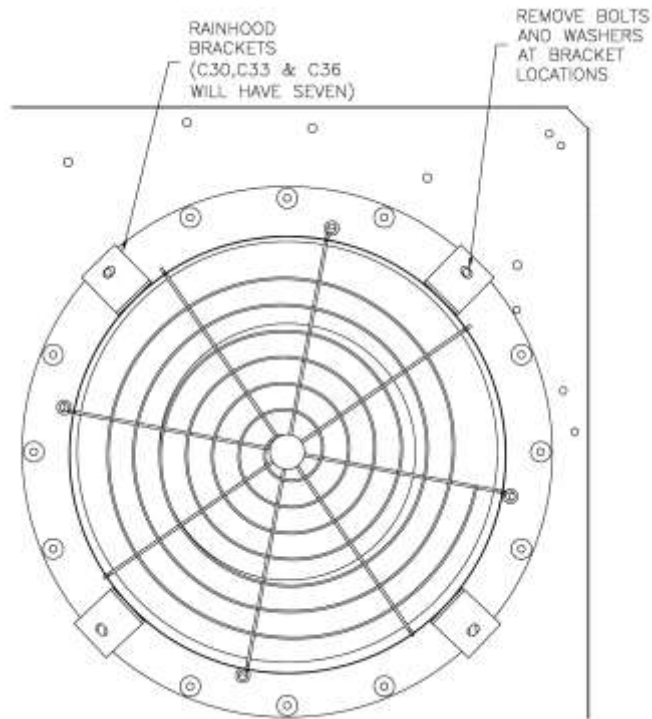

3. Field drill the seam as follows:
 - a. Drill first 5/16" diameter hole, 1-1/2" in from the outside edge of the rain hood skin.
 - b. Drill the second 5/16" diameter hole, 2-1/2" from inside edge of rain hood skin.
 - c. Drill the third hole, centered between the first and second holes.
 - d. Secure seam using 1/4" x 1/2" slot head machine screws, lock washers and hex nuts.

