

CBEG PIPE CONTROL

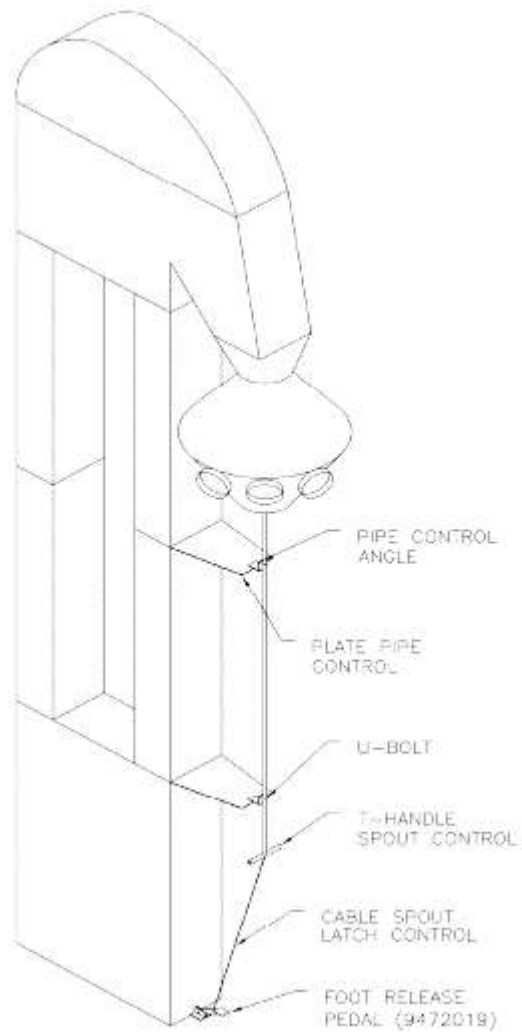

INSTALLATION MANUAL

P/N 126049 Rev 0

CHIEF 
AGRI/INDUSTRIAL

*We Engineer
Relationships®*

Installation Manual



This symbol means “Attention! Be Alert! Your Safety Is At Stake!”

The safety alert symbol identifies safety messages for your equipment. Ensure you are familiar with the messages identified for you with the safety alert symbol. When you see this symbol, be alert to the possibility of serious injury or death. Follow the safety instructions given in this manual for your equipment.

Danger: Indicates an imminently hazardous situation which, if not avoided, will result in death or serious injury.

Warning: Indicates a potentially hazardous situation which, if not avoided, could result in death or serious injury and property damage.

Caution: Indicates a potentially hazardous situation which, if not avoided, may result in minor or moderate injury. It may also be used to alert against unsafe practices.



WARNING: Improper installation, adjustment, alteration, service or maintenance can cause property damage, injury or death. Read the installation, operating and maintenance instructions thoroughly before installing or servicing this equipment.

This manual is for the installation of Chief material handling equipment effective 1/1/2016.

© Chief Industries, Inc.
4400 East 39th Street • PO Box 848
Kearney, NE 68847
Phone 800.359.7600

For more information about Chief Industries, Inc. and additional products or services please visit our website
www.agri.Chiefind.com

Table of Contents

Before You Begin	5
Safety and Precautions	6
General Contractor Responsibilities	7
Concrete Design and Construction	Error! Bookmark not defined.
Accessory Equipment	7
Field Modifications and Installation Defects	8
Packing List.....	8
Suggested Equipment.....	8
Crane Weight Capacity	Error! Bookmark not defined.
Part Identification	9
Assembly Bolting Sequence	11
Boot Section Installation.....	Error! Bookmark not defined.
Leg Section Installation	Error! Bookmark not defined.
Head Section Installation.....	Error! Bookmark not defined.
Assembly Inspection	Error! Bookmark not defined.
Crane Hoisting	Error! Bookmark not defined.
Setting and Guying the Elevator	Error! Bookmark not defined.
Anchors for Guy Cable Installation	Error! Bookmark not defined.
Guy Cable Installation	Error! Bookmark not defined.
Belt and Bucket Installation.....	Error! Bookmark not defined.
Belt Installation	Error! Bookmark not defined.
Temporary Belt Splice.....	Error! Bookmark not defined.
Bucket Installation.....	Error! Bookmark not defined.
Final Belt Splice	Error! Bookmark not defined.
Belt Tension Adjustment	Error! Bookmark not defined.
Discharge Baffle Adjustment	Error! Bookmark not defined.
Start up and Operation	Error! Bookmark not defined.
Periodic Maintenance.....	Error! Bookmark not defined.
Troubleshooting.....	Error! Bookmark not defined.
Manual Revisions	12
STANDARD LIMITED WARRANTY	13

Introduction

Thank you for purchasing a Chief bucket elevator accessory. Proper installation and operation will ensure you the best overall experience with your equipment and guarantee smooth operation.

This proprietary information is loaned with the expressed agreement that the drawings and information therein contained are the property of Chief Industries, Inc. and will not be reproduced, copied, or otherwise disposed of, directly or indirectly, and will not be used in whole or in part to assist in making or to furnish any information for the making of drawings, prints or other reproduction hereof, or for the making of additional products or equipment except upon written permission of Chief Industries, Inc. first obtained and specific as to each case. The acceptance of this material will be construed as an acceptance of the foregoing agreement.

The technical data contained herein is the most recent available at the time of publication and is subject to modification without notice. Chief Industries, Inc. reserves the right to modify the construction and method of operation of their products at any time without any obligation on their part to modify any equipment previously sold and delivered.

Model Number Description

The model nomenclature distinguishes the application of the bucket elevator. The information includes a designation of the applicable structure diameter, eave height, roof design and design criteria utilized. The definition of the model number nomenclature is as follows:

Example: CBEG 36 - 105 - 5000 - 8X10
 (a) (b) - (c) - (d) - (e)

- (a) CBEG = Chief bucket elevator galvanized
- (b) 36 = Bucket elevator pulley diameter
 Where: 36 = 36 inches in diameter
- (c) 105 = Bucket elevator discharge height
 Where: 105 = 105 feet in height from base of boot to discharge
- (d) 5000 = Elevator capacity
 Where: 5000 = 5,000 BPH design
- (e) 8X10 = Leg section
 Where: 8 = 8" length
 Where 10 = 10" depth



Before You Begin

Read this manual thoroughly before operating this bucket elevator. Keep this manual in a location for quick access and reference.

Your equipment is designed for safe and reliable operation when properly installed. However the fan requires electricity, which when improperly installed or when operated improperly, can be potentially dangerous. Anyone who will operate this unit should read the manual before installing or operating this unit. The following table, provided for your convenience, will aid in verifying that these individuals understand the proper operation of the bucket elevator. After completely reading the manual, this table should be filled in.

Date	Operator Signature	Owner Signature

Special Service Note: If you are unable to remedy any service problem after thoroughly studying this manual, contact the dealer from whom you purchased the unit. Your dealer is your first line of service. The following information is required for service:

1. Bucket elevator model number: _____
2. Bucket elevator serial number: _____
3. Head diameter: _____
4. Discharge height: _____
5. Motor RPM: _____
6. Motor HP: _____
7. Type of grain stored: _____
8. Grain Volume: _____
9. Dealer purchased from: _____
10. Dealer address and phone number: _____
11. Date purchased: _____
12. Service contractor:
 - a. Name: _____
 - b. Address: _____
 - c. Phone: _____



Safety and Precautions

Your safety and the safety of others is a primary concern to Chief Industries, Inc. This manual was written to assist in the safe installation and operation of the bucket elevator.

It is your responsibility as the owner, builder, operator, or supervisor to know what specific requirements, precautions and hazards exist and to make these known to all personnel working with equipment or on the jobsite so that they can observe any necessary safety precautions.

All personnel, including the installation crew, must read and understand the information contained in this manual before starting construction. Chief Industries, Inc. is not responsible or liable for the misuse of equipment or operation of personnel or equipment in an unsafe manner.

Chief Industries, Inc. assumes no liability with respect to proper construction and inspection, assembly, or use of its products established under applicable laws, all of which is the sole responsibility of the purchaser and those authorized for the installation.

Follow all local and federal safety laws and regulations. Verify that all equipment and personnel conform to any applicable jurisdiction regulations.

Work Area Safety Statement

To ensure the safety of all individuals in the work area, only authorized and trained persons shall install, and maintain the bucket elevator.

Under no circumstances should unauthorized individuals be allowed to trespass or be present in the work area.

It shall be the duty of all operators to ensure that the work area is clean, organized and kept free of all debris and tools that might cause an accidental tripping or falling hazard.

Special care should be taken when working from unsafe heights. Common sense dictates that when conditions such as rain or wind prohibit the safe use of equipment, the installation be discontinued.

Chief Industries, Inc. strongly recommends that equipment meeting the current specifications be used, whether the individual operator is required by law to do so or not. Proper climbing equipment and a secured safety harness should be used at all times when performing operations work, installation or maintenance.

Field modifications without the authorization of the manufacturer may present unknown dangers to the operator and must be avoided.

Auxiliary Equipment Safety

You may decide to purchase and install “auxiliary equipment” made by other manufacturers. Chief Industries, Inc. has no control over the design and manufacture of this equipment. In view of this, at a minimum, we suggest you do the following:

1. Obtain, read and understand the instructions and safety cautions of the auxiliary equipment manufacturer. Be certain that all equipment is installed in agreement with those instructions.
2. Check with Chief Industries, Inc. to verify that your system is designed to support any additional loads supplied by the auxiliary equipment.
3. Obtain any applicable safety decals from the manufacturer and make certain they are displayed in a visible location.
4. Make certain that all electrical equipment is properly installed and grounded by a qualified electrician.
5. Check availability and operation of electrical lock out and emergency stop systems.
6. Be certain that all guards and shields are securely in place.
7. Store all operation / maintenance manuals in a safe place for future use.

General Contractor Responsibilities

It is the responsibility of the general contractor to insure that the complete grain handling system is constructed with quality workmanship and that all equipment is installed per the respective manufacturer's instructions. This includes the following:

- Accessory equipment

In addition, the general contractor is responsible for the fitness of use of any system which he constructs. All accessory equipment incorporated into the system, from each respective equipment manufacturer, should be approved for the intended use.

Accessory Equipment

Accessory equipment can be installed with the bucket elevator; however certain limitations and special considerations must be followed in order to maintain the warranty.

All accessory equipment should be installed and maintained in accordance with each individual supplier's installation and operation instructions. However, if any sidewall penetrations or other modifications to the Chief standard design are required, contact Chief for special recommendations.

Note: Do not modify the equipment design without Chief approval. It is the responsibility of the general contractor to insure that all equipment is properly installed and that the equipment is compatible with the intended use. A qualified electrician should be contracted to complete all electrical wiring and servicing.

Field Modifications and Installation Defects

Chief Industries, Inc. assumes no responsibility for field modifications or installation defects which result in structural damage or storage quality problems. If any field modifications are necessary which are not specifically covered by the contents of the installation manual, contact Chief for approval. Any unauthorized modification or installation defect which affects the structural integrity of the bucket elevator will void the warranty.

Packing List

For your convenience all packages will be color coded, individual items labeled with an appropriate part number and packages labeled. Hardware, including bolts, nuts, screws and other small clips or brackets may be divided into smaller packages for ease of use and identification.

Verify and inspect all items carefully when unpacking and before installing. This should be done at the time of pickup or delivery. Compare the items to the packing list provided with the shipment. In case of any shortage or damage during shipment, note such shortage or damage on the freight bill before you sign the shipment paperwork and file a claim with the carrier.

Claims of shortages will not be honored after thirty days from receipt of shipment. Parts that are short or damaged are the responsibility of the delivering carrier, not the manufacturer or dealer.

It is advisable to reorder damaged or missing parts immediately so that there will be no delay in the installation. After receiving the invoice for the reordered material, file a claim with the delivering carrier immediately.

Suggested Equipment

Chief recommends the following equipment and tools needed for installation of the bucket elevator. Individual installations may vary.

- Impact wrenches and sockets
- End wrenches
- Crescent wrenches
- Vise grip pliers
- Alignment punches
- Rubber mallets
- Level
- Drill and drill bits
- Screw Guns
- Metal Saw
- Extension cords
- Ladders

Part Identification

The cable control kit allows the operation of the distributor from ground level. Use the following information to identify parts used during installation.

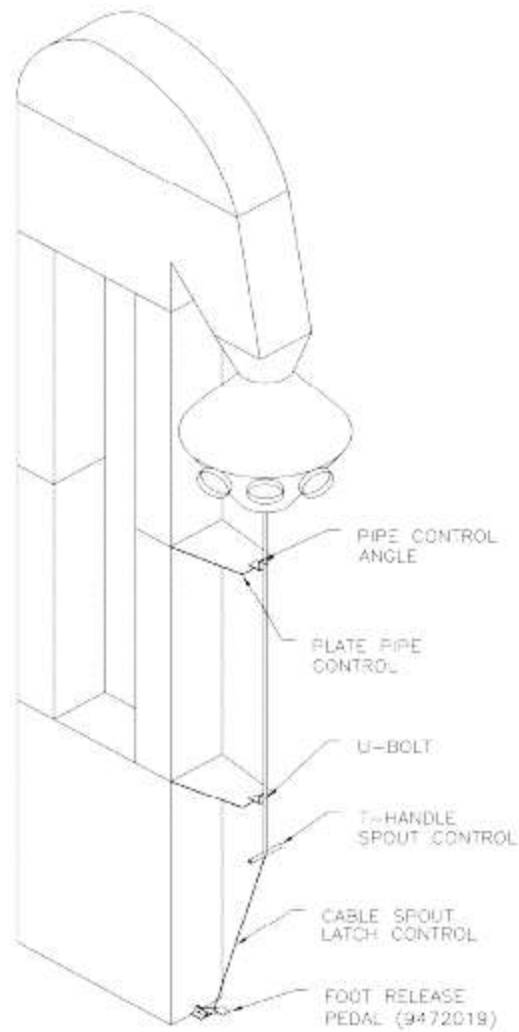

Installation Procedures

When installing hardware the minimum and maximum torque values shown below must be followed. All hardware must seat tight against the corresponding component.

Bolt Diameter	Minimum Torque	Maximum Torque
5/16" (.79cm)	22 ft.-lbs.	28 ft.-lbs.
7/16" (1.11cm)	60 ft.-lbs.	75 ft.-lbs.
1/2" (1.27cm)	50 ft.-lbs.	58 ft.-lbs.
5/8" (1.58cm)	105 ft.-lbs.	121 ft.-lbs.
3/4" (1.90cm)	175 ft.-lbs.	201 ft.-lbs.

Please note the following wrench / socket size to be used on the corresponding hardware:

Bolt Size	Head Size	Nut Size
5/16"	1/2" wrench	1/2" wrench
7/16"	5/8" wrench	11/16" wrench
1/2"	3/4" wrench	3/4" wrench
5/8"	15/16" wrench	15/16" wrench
3/4"	1-1/8" wrench	1-1/8" wrench

Assembly Sequence (Lock Form Elevator Leg Sections)

1. Attach the pipe into the bottom of the distributor and securely tighten the couplings.
2. Attach the plate pipe control assembly to the bucket elevator leg trunking. **Note:** The pipe control assembly must be inline with the pipe to allow the pipe to move freely.

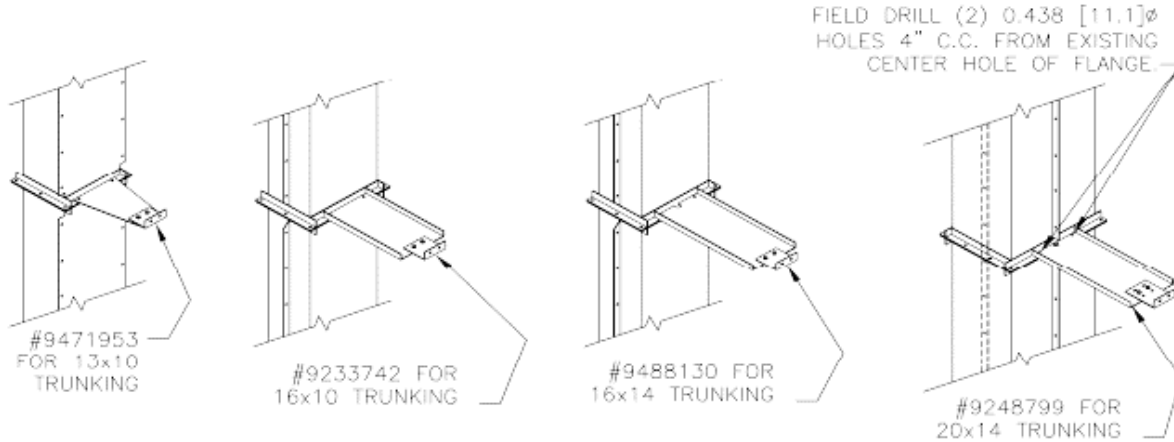

3. Cut off a section of pipe a minimum of 12" (30.48cm) long to be used as a t-handle. The t-handle is field welded in place.
4. Install the t-handle to the end of the pipe spout control. **Note:** The t-handle should be located so the operator can easily operate the equipment from the work room floor.

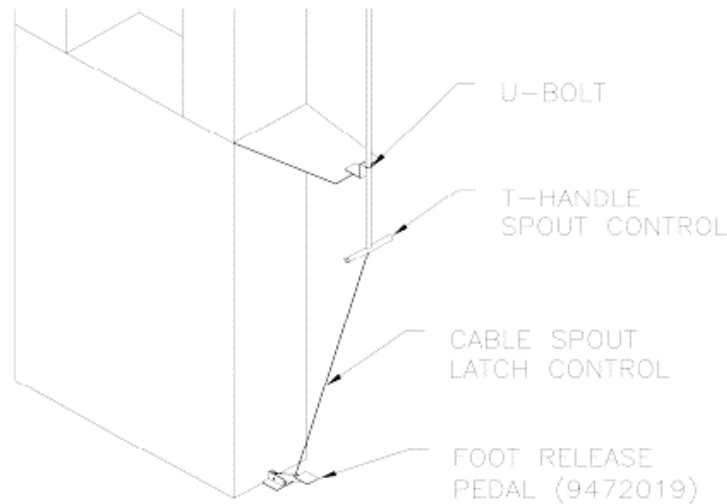

5. Locate the foot pedal release so that it can be operated at the same time the t-handle is being turned. The pedal will require anchoring to the floor with concrete fasteners (not provided).
6. The cable for the spout latch inside the distributor should now be installed. Route the cable through the distributor and then down thru the pipe. Secure the cable to the spout latch with a cable clamp. Secure the opposite end of the cable to the foot pedal with a cable clamp. Verify there is sufficient tension on the cable so that the distributor spout latch is released when the foot pedal is depressed.
7. Verify that all cables move freely with no interference during operation.

Manual Revisions

- 8-20-2014
 - Warranty information
- 1-1-2016
 - General formatting update

STANDARD LIMITED WARRANTY

Material Handling Products

1. **Definitions.** The following terms, when they appear in the body of this Standard Limited Warranty for Material Handling Products in initial capital letters shall have the meaning set forth below:
 - A. Accepted Purchase Order shall mean the Purchase Order identified below.
 - B. Chief shall mean Chief Agri/Industrial, a division of Chief Industries, Inc.
 - C. Original Owner shall mean the original owner identified below.
 - D. Product shall mean the Agri/Industrial Equipment as described in the Accepted Purchase Order.
 - E. Reseller shall mean the authorized Chief Agri/Industrial Equipment dealer identified below.

2. **Limited Product Warranty.** Upon and subject to the terms and conditions set forth below, Chief hereby warrants to the Reseller, and, if different, the Original Owner as follows:
 - A. All new Products delivered to the Reseller or the Original Owner by Chief pursuant to the Accepted Purchase Order will, when delivered, conform to the specifications set forth in the Accepted Purchase Order;
 - B. All new Products delivered pursuant to the Accepted Purchase Order will, in normal use and service, be free from defects in materials or workmanship; and
 - C. Upon delivery, Chief will convey good and marketable title to the Products, free and clear of any liens or encumbrances except for, where applicable, a purchase money security interest in favor of Chief.

3. **Duration of Warranty and Notice Requirements.** Subject to the **Exceptions, Exclusions and Limitations** set forth below, the warranties set forth in Section 2 above shall apply to all covered non-conforming conditions that are discovered within the first twenty-four (24) months following delivery of the Product to the carrier designated by the Reseller and/or the Original Owner at Chief's manufacturing facility in Kearney, Nebraska (the "Warranty Period") and are reported to the Chief as provided in Section 4 below within thirty (30) days following discovery (a "Notice Period").

4. **Notice Procedure.** In order to make a valid warranty claim, the Reseller and/or the Original Owner must provide Chief with a written notice of any nonconforming condition discovered during the Warranty Period within the applicable Notice Period specified in Section 3 above. Said notice must be in writing; be addressed to Chief Industries, Inc., Agri/Industrial Division, Customer Service Department, P.O. Box 848, Kearney, NE 68848; and contain the following information: (a) the Customer's name and address; (b) the Reseller's name and address; (c) the make and model of the Product in question; (d) the current location of the Product; (e) a brief description of the problem with respect to which warranty coverage is claimed; and (f) the date on which the Product was purchased.

5. **Exceptions and Exclusions.** Anything herein to the contrary notwithstanding, the warranties set forth in Section 2 above do **not** cover any of the following, each of which are hereby expressly excluded:
 - A. Defects that are not discovered during the applicable Warranty Period;
 - B. Defects that are not reported to the Chief Agri/Industrial Division Customer Service Department in conformity with the notice procedure set forth in Section 4 above within the applicable Notice Period specified in Section 3;
 - C. Any used or pre-owned Products;
 - D. Any Chief manufactured parts that are not furnished as a part of the Accepted Purchase Order;
 - E. Any fixtures, equipment, materials, supplies, accessories, parts or components that have been furnished by Chief but are manufactured by a third party;
 - F. Any Products which have been removed from the location at which they were originally installed;
 - G. Any defect, loss, damage, cost or expense incurred by the Reseller or the Original Owner to the extent the same arise out of, relate to or result, in whole or in part, from any one or more of the following:
 - (i) Usual and customary deterioration, wear or tear resulting from normal use, service and exposure;

- (ii) Theft, vandalism, accident, war, insurrection, fire or other casualty;
- (iii) Any damage, shortages or missing parts which result during shipping or are otherwise caused by the Reseller, the Original Owner and/or any third party;
- (iv) Exposure to marine environments, including frequent or sustained salt or fresh water spray;
- (v) Exposure to corrosive, chemical, ash, smoke, fumes, or the like generated or released either within or outside of the structure on which the Product is installed, regardless of whether or not such facilities are owned or operated by the Reseller, the Original Owner or an unrelated third party;
- (vi) Exposure to or contact with animals, animal waste and/or decomposition;
- (vii) The effect or influence the Product may have on surrounding structures, including, without limitation, any loss, damage or expense caused by drifting snow;
- (viii) Any Product or portion thereof that has been altered, modified or repaired by the Reseller, the Original Owner or any third party without Chief's prior written consent;
- (ix) Any Product or portion thereof that has been attached to any adjacent structure without Chief's prior written approval;
- (x) Any Product to which any fixtures, equipment, accessories, materials, parts or components which were not provided as a part of the original Accepted Purchase Order have been attached without Chief's prior written approval;
- (xi) The failure on the part of the Reseller, the Original Owner or its or their third party contractors to satisfy the requirements of all applicable statutes, laws, ordinances rules, regulations and codes, (including zoning laws and/or building codes);
- (xii) The use of the Product for any purpose other than the purpose for which it was designed; and/or
- (xiii) The failure of the Reseller, the Original Owner and/or any third party to:
 - (a) properly handle, transport and/or store the Product or any component part thereof;
 - (b) properly select and prepare a site that is adequate for the installation and/or operation of the Product or any component part thereof;
 - (c) properly design and construct a foundation that is adequate for the installation and/or operation of the Product or any component part thereof;
 - (d) properly set up, erect, construct or install the Product and/or any component part thereof; and/or
 - (e) properly operate, use, service and/or maintain the Product and each component part thereof.

6. **Resolution of Warranty Claims.** In the event any nonconforming condition is discovered within the Warranty Period and Chief is notified of a warranty claim as required by Section 4 prior to the end of the applicable Notice Period set forth in Section 3 above, Chief shall, with the full cooperation of the Reseller and the Original Owner, immediately undertake an investigation of such claim. To the extent Chief shall determine, in its reasonable discretion, that the warranty claim is covered by the foregoing Limited Product Warranty, the following shall apply:

A. Warranty Claims With Respect to Covered Non-Conforming Conditions Discovered Within the First Three Hundred Sixty Five (365) Days and Reported to Chief Within Thirty (30) Days of Discovery. In the case of a warranty claim which relates to a covered non-conforming condition that is discovered during the first three hundred sixty five (365) days of the Warranty Period and is reported to Chief as required by Section 4 within thirty (30) days of discovery as required by Section 3, Chief will, as Chief's sole and exclusive obligation to the Reseller and the Original Owner, and as their sole and exclusive remedy, work in cooperation with the Reseller and the Original Owner to correct such non-conforming condition, and in connection therewith, Chief will ship any required replacement parts to the "ship to address" set forth in the Accepted Purchase Order FOB Chief's facilities in Kearney, Nebraska, and will either provide the labor or reimburse the Reseller or the Original Owner, as may be appropriate in the circumstances, for any out of pocket expense the Original Owner may reasonably and necessarily incur for the labor that is required to correct such non-conforming condition, provided that if work is to be performed by the Reseller or a third party contractor, Chief may require at least two competitive bids to perform the

- labor required to repair or correct the defect and reserves the right to reject all bids and obtain additional bids. Upon acceptance of a bid by Chief, Chief will authorize the necessary repairs.
- B. **All Other Warranty Claims.** Except as is otherwise provided in subsection 6A above, in the case of all other warranty claims which relate to covered non-conforming conditions that are discovered during the Warranty Period and are reported to Chief as required by Section 4 within thirty (30) days following discovery, Chief will, as Chief's sole and exclusive obligation to the Reseller and the Original Owner, and as the Reseller's and the Original Owner's sole and exclusive remedy, ship any required replacement parts to the Original Owner at the "ship to address" specified in the Accepted Purchase Order FOB Chief's facilities in Kearney, Nebraska; and **in such event, Chief shall have no responsibility or liability to either the Reseller or the Original Owner for the cost of any labor required to repair or correct the defect.**
7. **Warranty Not Transferable.** This Warranty applies only to the Reseller and the Original Owner and is **not transferable**. As such, this Warranty does **not** cover any Product that is sold or otherwise transferred to any third party following its delivery to the Original Owner.
8. **Limitation on Warranties, Liabilities and Damages.** The Reseller and the Original Owner expressly agree that the allocation of the risk, liability, loss, damage, cost and expense arising from any Product that does not conform to the limited warranty given in Section 2 above are fair and reasonable and acknowledge that such allocation was expressly negotiated by the parties and was reflected in the Purchase Price of the Product. Accordingly the Reseller and the Original Owner expressly agree as follows:
- A. **Disclaimer of Implied Warranties.** EXCEPT AS IS OTHERWISE EXPRESSLY SET FORTH HEREIN, CHIEF MAKES NO OTHER REPRESENTATIONS OR WARRANTIES OF ANY KIND WHATSOEVER, WHETHER EXPRESS OR IMPLIED, BY OPERATION OF LAW, COURSE OF DEALING OR OTHERWISE WITH RESPECT TO THE PRODUCT, ANY COMPONENT PART THEREOF OR ANY OTHER GOODS OR SERVICES THAT CHIEF MANUFACTURES, FABRICATES, PRODUCES, SELLS OR PROVIDES TO THE DEALER OR THE ORIGINAL OWNER PURSUANT TO THE TERMS OF ANY ACCEPTED PURCHASE ORDER, INCLUDING WITHOUT LIMITATION ANY REPRESENTATION OR WARRANTY WITH RESPECT TO DESIGN, CONDITION, MERCHANTABILITY OR FITNESS OF THE PRODUCT OR ANY OTHER GOODS OR SERVICES FOR ANY PARTICULAR PURPOSE OR USE.
- B. **Limitation on Liability.** EXCEPT AS IS OTHERWISE EXPRESSLY SET FORTH IN SECTION 6 ABOVE, CHIEF'S LIABILITY TO THE DEALER AND/OR THE ORIGINAL OWNER WITH RESPECT TO ANY DEFECTS IN ANY PRODUCTS OR FOR ANY OTHER GOODS OR SERVICES WHICH DO NOT CONFORM TO THE WARRANTIES SET FORTH ABOVE SHALL NOT, IN ANY EVENT, EXCEED THE ACTUAL COST OF SUCH NON-CONFORMING PRODUCT, GOODS OR SERVICES AS DETERMINED PURSUANT TO THE ACCEPTED PURCHASE ORDER; AND
- C. **Limitation on the Nature of Damages.** EXCEPT AS EXPRESSLY PROVIDED IN SECTION 6 ABOVE, CHIEF SHALL NOT, UNDER ANY CIRCUMSTANCES, BE LIABLE TO THE DEALER, THE ORIGINAL OWNER OR ANY THIRD PARTY FOR ATTORNEY FEES COURT COSTS OR ANY OTHER SPECIAL, INDIRECT, INCIDENTAL, CONSEQUENTIAL, LIQUIDATED OR PUNITIVE DAMAGES OF ANY NAME, NATURE OR DESCRIPTION AS A RESULT OF THE FAILURE OF ANY PRODUCT OR ANY OTHER GOODS OR SERVICES PURCHASED BY THE DEALER OR THE ORIGINAL OWNER FROM CHIEF PURSUANT TO THE ACCEPTED PURCHASE ORDER TO CONFORM TO THE LIMITED WARRANTIES SET FORTH IN SECTION 2 ABOVE.
8. **Applicable Law.** This Limited Product Warranty has been issued, accepted and entered into by the Reseller, the Original Owner and Chief in the State of Nebraska and shall be governed by, and construed in accordance with, the internal laws of the State of Nebraska. Any legal action or proceeding with respect to any goods or services furnished to the Original Owner by Chief in connection herewith, or any document related hereto shall be brought only in the district courts of Nebraska, or the United States District Court for the District of Nebraska, and, by execution and delivery of this Limited Product Warranty, the undersigned Original Owner hereby accept for themselves and with respect to their property, generally and unconditionally, the jurisdiction of the aforesaid courts. Further, the undersigned Original Owner hereby irrevocably waives any objection,

including, without limitation, any forum non conveniens, which it may now or hereafter have to the bringing of such action or proceeding in such respective jurisdictions.

ACKNOWLEDGMENT OF RECEIPT

By its signature hereto, the undersigned Reseller represents and warrants to Chief that the Reseller has provided a true, correct and complete copy of this Standard Limited Warranty to the Original Owner at the time the product was purchased.

Reseller Name and Address: _____

Original Owner Name and Address: _____

Accepted Purchase Order No. _____

Original Jobsite Address: _____

RESELLER:

By: _____
Date

Print name and title

4831-5139-8433, v. 1



Should you have any questions concerning assembly instructions, parts or drawings, please feel free to contact us at any of the following.

© Chief Industries, Inc. Inc.
4400 East 39th Street • PO Box 848
Kearney, NE 68847
Phone 800.359.7600

For more information about Chief Industries, Inc. and additional products or services visit our website
www.agri.Chiefind.com