

UNDER FLOOR CHAIN CONVEYOR



INSTALLATION MANUAL
P/N 144374



Trusted. Tested. True.

Chief Industries, Inc. – Agri/Industrial Division

Table of Contents

Manual Revisions	3
Standard Limited Warranty	4
Before You Begin	10
General Design Information.....	12
Accessory Equipment.....	12
General Contractor Responsibilities	12
Field Modifications and Installation Defects	12
Checking Shipment.....	12
Suggested Equipment	14
Hardware Torque.....	14
Chain conveyor Safety	15
Pre-Installation Planning Information.....	16
Component Identification.....	18
Component Installation.....	21
Horizontal Body Assembly.....	21
Chain Installation	23
Chain Tension.....	24
Drive Installation	26
Inlet Gate Installation.....	31
Controller Installation.....	33
Bin Flashing Installation.....	35
Floor Support Installation.....	37
Slack Chain Sensor Installation.....	39
Start up and Operation	42
Periodic Maintenance	444
Troubleshooting.....	455
Manufacturer Data / Recommendations	478

Manual Revisions

© Chief Industries, Inc.
4400 East 39th Street • PO Box 848
Kearney, NE 68847
Phone 800.359.7600

For more information about Chief Industries, Inc. and additional products or services please visit our website

www.agri.Chiefind.com

STANDARD LIMITED WARRANTY

Material Handling Products

1. **Definitions**. The following terms, when they appear in the body of this Standard Limited Warranty for Material Handling Products in initial capital letters shall have the meaning set forth below:
 - A. Accepted Purchase Order shall mean the Purchase Order identified below.
 - B. Chief shall mean Chief Agri/Industrial, a division of Chief Industries, Inc.
 - C. Original Owner shall mean the original owner identified below.
 - D. Product shall mean the Agri/Industrial Equipment as described in the Accepted Purchase Order.
 - E. Reseller shall mean the authorized Chief Agri/Industrial Equipment dealer identified below.
2. **Limited Product Warranty**. Upon and subject to the terms and conditions set forth below, Chief hereby warrants to the Reseller, and, if different, the Original Owner as follows:
 - A. All new Products delivered to the Reseller or the Original Owner by Chief pursuant to the Accepted Purchase Order will, when delivered, conform to the specifications set forth in the Accepted Purchase Order;
 - B. All new Products delivered pursuant to the Accepted Purchase Order will, in normal use and service, be free from defects in materials or workmanship; and
 - C. Upon delivery, Chief will convey good and marketable title to the Products, free and clear of any liens or encumbrances except for, where applicable, a purchase money security interest in favor of Chief.
3. **Duration of Warranty and Notice Requirements**. Subject to the **Exceptions, Exclusions and Limitations** set forth below, the warranties set forth in Section 2 above shall apply to all covered non-conforming conditions that are discovered within the first twenty-four (24) months following delivery of the Product to the carrier designated by the Reseller and/or the Original Owner at Chief's manufacturing facility in Kearney, Nebraska (the "Warranty Period") and are reported to the Chief as provided in Section 4 below within thirty (30) days following discovery (a "Notice Period").
4. **Notice Procedure**. In order to make a valid warranty claim, the Reseller and/or the Original Owner must provide Chief with a written notice of any nonconforming condition discovered during the Warranty Period within the applicable Notice Period specified in Section 3 above. Said notice must be in writing; be addressed to Chief Industries, Inc., Agri/Industrial Division, Customer Service Department, P.O. Box 848, Kearney, NE 68848; and contain the following information: (a) the Customer's name and address; (b) the Reseller's name and address; (c) the make and model of the Product in question; (d) the current location of the Product; (e) a brief description of the problem with respect to which warranty coverage is claimed; and (f) the date on which the Product was purchased.
5. **Exceptions and Exclusions**. Anything herein to the contrary notwithstanding, the warranties set forth in Section 2 above do **not** cover any of the following, each of which are hereby expressly excluded:
 - A. Defects that are not discovered during the applicable Warranty Period;
 - B. Defects that are not reported to the Chief Agri/Industrial Division Customer Service Department in conformity with the notice procedure set forth in Section 4 above within the applicable Notice Period specified in Section 3;

- C. Any used or pre-owned Products;
- D. Any Chief manufactured parts that are not furnished as a part of the Accepted Purchase Order;
- E. Any fixtures, equipment, materials, supplies, accessories, parts or components that have been furnished by Chief but are manufactured by a third party;
- F. Any Products which have been removed from the location at which they were originally installed;
- G. Any defect, loss, damage, cost or expense incurred by the Reseller or the Original Owner to the extent the same arise out of, relate to or result, in whole or in part, from any one or more of the following:
 - (i) Usual and customary deterioration, wear or tear resulting from normal use, service and exposure;
 - (ii) Theft, vandalism, accident, war, insurrection, fire or other casualty;
 - (iii) Any damage, shortages or missing parts which result during shipping or are otherwise caused by the Reseller, the Original Owner and/or any third party;
 - (iv) Exposure to marine environments, including frequent or sustained salt or fresh water spray;
 - (v) Exposure to corrosive, chemical, ash, smoke, fumes, or the like generated or released either within or outside of the structure on which the Product is installed, regardless of whether or not such facilities are owned or operated by the Reseller, the Original Owner or an unrelated third party;
 - (vi) Exposure to or contact with animals, animal waste and/or decomposition;
 - (vii) The effect or influence the Product may have on surrounding structures, including, without limitation, any loss, damage or expense caused by drifting snow;
 - (viii) Any Product or portion thereof that has been altered, modified or repaired by the Reseller, the Original Owner or any third party without Chief's prior written consent;
 - (ix) Any Product or portion thereof that has been attached to any adjacent structure without Chief's prior written approval;
 - (x) Any Product to which any fixtures, equipment, accessories, materials, parts or components which were not provided as a part of the original Accepted Purchase Order have been attached without Chief's prior written approval;
 - (xi) The failure on the part of the Reseller, the Original Owner or its or their third party contractors to satisfy the requirements of all applicable statutes, laws, ordinances rules, regulations and codes, (including zoning laws and/or building codes);
 - (xii) The use of the Product for any purpose other than the purpose for which it was designed; and/or
 - (xiii) The failure of the Reseller, the Original Owner and/or any third party to:
 - (a) properly handle, transport and/or store the Product or any component part thereof;
 - (b) properly select and prepare a site that is adequate for the installation and/or operation of the Product or any component part thereof;
 - (c) properly design and construct a foundation that is adequate for the installation and/or operation of the Product or any component part thereof;
 - (d) properly set up, erect, construct or install the Product and/or any component part thereof; and/or
 - (e) properly operate, use, service and/or maintain the Product and each component part thereof.

6. **Resolution of Warranty Claims.** In the event any nonconforming condition is discovered within the Warranty Period and Chief is notified of a warranty claim as required by Section 4 prior to the end of the applicable Notice Period set forth in Section 3 above, Chief shall, with the full cooperation of the Reseller and the Original Owner, immediately undertake an investigation of such claim. To the extent Chief shall determine, in its reasonable discretion, that the warranty claim is covered by the foregoing Limited Product Warranty, the following shall apply:
- A. **Warranty Claims With Respect to Covered Non-Conforming Conditions Discovered Within the First Three Hundred Sixty Five (365) Days and Reported to Chief Within Thirty (30) Days of Discovery.** In the case of a warranty claim which relates to a covered non-conforming condition that is discovered during the first three hundred sixty five (365) days of the Warranty Period and is reported to Chief as required by Section 4 within thirty (30) days of discovery as required by Section 3, Chief will, as Chief's sole and exclusive obligation to the Reseller and the Original Owner, and as their sole and exclusive remedy, work in cooperation with the Reseller and the Original Owner to correct such non-conforming condition, and in connection therewith, Chief will ship any required replacement parts to the "ship to address" set forth in the Accepted Purchase Order FOB Chief's facilities in Kearney, Nebraska, and will either provide the labor or reimburse the Reseller or the Original Owner, as may be appropriate in the circumstances, for any out of pocket expense the Original Owner may reasonably and necessarily incur for the labor that is required to correct such non-conforming condition, provided that if work is to be performed by the Reseller or a third party contractor, Chief may require at least two competitive bids to perform the labor required to repair or correct the defect and reserves the right to reject all bids and obtain additional bids. Upon acceptance of a bid by Chief, Chief will authorize the necessary repairs.
- B. **All Other Warranty Claims.** Except as is otherwise provided in subsection 6A above, in the case of all other warranty claims which relate to covered non-conforming conditions that are discovered during the Warranty Period and are reported to Chief as required by Section 4 within thirty (30) days following discovery, Chief will, as Chief's sole and exclusive obligation to the Reseller and the Original Owner, and as the Reseller's and the Original Owner's sole and exclusive remedy, ship any required replacement parts to the Original Owner at the "ship to address" specified in the Accepted Purchase Order FOB Chief's facilities in Kearney, Nebraska; and **in such event, Chief shall have no responsibility or liability to either the Reseller or the Original Owner for the cost of any labor required to repair or correct the defect.**
7. **Warranty Not Transferable.** This Warranty applies only to the Reseller and the Original Owner and is **not transferable**. As such, this Warranty does **not** cover any Product that is sold or otherwise transferred to any third party following its delivery to the Original Owner.
8. **Limitation on Warranties, Liabilities and Damages.** The Reseller and the Original Owner expressly agree that the allocation of the risk, liability, loss, damage, cost and expense arising from any Product that does not conform to the limited warranty given in Section 2 above are fair and reasonable and acknowledge that such allocation was expressly negotiated by the parties and was reflected in the Purchase Price of the Product. Accordingly the Reseller and the Original Owner expressly agree as follows:
- A. **Disclaimer of Implied Warranties.** **EXCEPT AS IS OTHERWISE EXPRESSLY SET FORTH HEREIN, CHIEF MAKES NO OTHER REPRESENTATIONS OR WARRANTIES OF ANY KIND WHATSOEVER, WHETHER EXPRESS OR IMPLIED, BY OPERATION OF LAW, COURSE OF DEALING OR OTHERWISE WITH RESPECT TO THE PRODUCT, ANY COMPONENT PART THEREOF OR ANY OTHER GOODS OR SERVICES THAT CHIEF**

MANUFACTURES, FABRICATES, PRODUCES, SELLS OR PROVIDES TO THE DEALER OR THE ORIGINAL OWNER PURSUANT TO THE TERMS OF ANY ACCEPTED PURCHASE ORDER, INCLUDING WITHOUT LIMITATION ANY REPRESENTATION OR WARRANTY WITH RESPECT TO DESIGN, CONDITION, MERCHANTABILITY OR FITNESS OF THE PRODUCT OR ANY OTHER GOODS OR SERVICES FOR ANY PARTICULAR PURPOSE OR USE.

B. Limitation on Liability. EXCEPT AS IS OTHERWISE EXPRESSLY SET FORTH IN SECTION 6 ABOVE, CHIEF'S LIABILITY TO THE DEALER AND/OR THE ORIGINAL OWNER WITH RESPECT TO ANY DEFECTS IN ANY PRODUCTS OR FOR ANY OTHER GOODS OR SERVICES WHICH DO NOT CONFORM TO THE WARRANTIES SET FORTH ABOVE SHALL NOT, IN ANY EVENT, EXCEED THE ACTUAL COST OF SUCH NON-CONFORMING PRODUCT, GOODS OR SERVICES AS DETERMINED PURSUANT TO THE ACCEPTED PURCHASE ORDER; AND

C. Limitation on the Nature of Damages. EXCEPT AS EXPRESSLY PROVIDED IN SECTION 6 ABOVE, CHIEF SHALL NOT, UNDER ANY CIRCUMSTANCES, BE LIABLE TO THE DEALER, THE ORIGINAL OWNER OR ANY THIRD PARTY FOR ATTORNEY FEES COURT COSTS OR ANY OTHER SPECIAL, INDIRECT, INCIDENTAL, CONSEQUENTIAL, LIQUIDATED OR PUNITIVE DAMAGES OF ANY NAME, NATURE OR DESCRIPTION AS A RESULT OF THE FAILURE OF ANY PRODUCT OR ANY OTHER GOODS OR SERVICES PURCHASED BY THE DEALER OR THE ORIGINAL OWNER FROM CHIEF PURSUANT TO THE ACCEPTED PURCHASE ORDER TO CONFORM TO THE LIMITED WARRANTIES SET FORTH IN SECTION 2 ABOVE.

8. Applicable Law. This Limited Product Warranty has been issued, accepted and entered into by the Reseller, the Original Owner and Chief in the State of Nebraska and shall be governed by, and construed in accordance with, the internal laws of the State of Nebraska. Any legal action or proceeding with respect to any goods or services furnished to the Original Owner by Chief in connection herewith, or any document related hereto shall be brought only in the district courts of Nebraska, or the United States District Court for the District of Nebraska, and, by execution and delivery of this Limited Product Warranty, the undersigned Original Owner hereby accept for themselves and with respect to their property, generally and unconditionally, the jurisdiction of the aforesaid courts. Further, the undersigned Original Owner hereby irrevocably waives any objection, including, without limitation, any forum non conveniens, which it may now or hereafter have to the bringing of such action or proceeding in such respective jurisdictions.

ACKNOWLEDGMENT OF RECEIPT

By its signature hereto, the undersigned Reseller represents and warrants to Chief that the Reseller has provided a true, correct and complete copy of this Standard Limited Warranty to the Original Owner at the time the product was purchased.

Reseller Name and Address: _____

Original Owner Name and Address: _____

Accepted Purchase Order No. _____

Original Jobsite Address: _____

RESELLER:

By: _____
Date

Print name and title

4831-5139-8433, v. 1

Warning

Water Sensitive Materials - Read this notice carefully

Items must be inspected and carrier advised immediately if damage is noted. White rust is a corrosion attack of the zinc coating resulting from the presence of water. Anywhere rust is found will result in a reduction of the life of the galvanized steel.

If water has entered a bundle or if condensation has formed between items, the bundle must be opened, the items separated and all surfaces dried.

If items are to be installed within 10 days:

Store bundled items off the ground high enough to allow air circulation beneath bundle and to prevent water from entering. Store 1 end at least 8" (20.32cm) higher than the opposite end. Support long bundles in the center. Prevent rain from entering the bundle by covering with a tarpaulin, making provision for air circulation between the draped edges and the ground.

Do not wrap in plastic.

If items are not to be installed within 10 days:

Provide inside dry storage. Storage beyond 6 months is not recommended. If white rust is apparent upon receipt of shipment, notify Chief immediately. Damage to items, resulting from improper storage, is the responsibility of the receiver.



Before You Begin

Before starting the installation of the under floor chain conveyor, take time to thoroughly study the construction methods in this manual, this will save you time and money.

Chief makes no warranty concerning components, accessories or equipment not manufactured by Chief.

When using a cutting torch or welding galvanized material, the possibility of developing toxic fumes will exist. Provide adequate ventilation and respiratory protection when using this type of equipment during installation.

Introduction

Thank you for purchasing a Chief under floor chain conveyor. Proper installation and operation will ensure you the best overall experience with your equipment and guarantee smooth operation.

This proprietary information is loaned with the expressed agreement that the drawings and information therein contained are the property of Chief Industries, Inc. and will not be reproduced, copied, or otherwise disposed of, directly or indirectly, and will not be used in whole or in part to assist in making or to furnish any information for the making of drawings, prints or other reproduction hereof, or for the making of additional products or equipment except upon written permission of Chief Industries, Inc. first obtained and specific as to each case. The acceptance of this material will be construed as an acceptance of the foregoing agreement.

The technical data contained herein is the most recent available at the time of publication and is subject to modification without notice. Chief Industries, Inc. reserves the right to modify the construction and method of operation of their products at any time without any obligation on their part to modify any equipment previously sold and delivered.

Important Note: If you are unable to remedy any service problem after thoroughly studying this manual, contact the dealer from whom you purchased the unit. Your dealer is your first line of service. The following information is required for service:

1. Chain conveyor model and serial number: _____
2. Sprocket size and number of teeth: _____
3. Overall length: _____
4. Motor RPM and HP: _____
5. Type of grain and capacity: _____
6. Dealer purchased from: _____
7. Dealer address and phone number: _____
8. Date purchased: _____
9. Service contractor:
 - a. Name: _____
 - b. Address: _____
 - c. Phone: _____

Model Number Description

The model nomenclature distinguishes the application of the under floor chain conveyor. The information includes a designation of the applicable width, height, and length. The definition of the model number nomenclature is as follows:

Example: CUFC 17 - 09 - 135

(a) (b) - (c) - (d)

(a) CUFC = Chief Under Floor Conveyor

(b) 17 = Chain conveyor width

Where: 17= 17 inches in width

(c) 09 = Chain conveyor height

Where: 09 = 09 inches in height

(d) 135 = Chain conveyor inlet to outlet length

Where: 135 = 135 feet in length

General Design Information

All steel materials are purchased in accordance with the applicable ASTM Standard.

All bolted connections are designed using high strength bolts which meet the specifications of the applicable ASTM or SAE standard.

All galvanized steel conform to ASTM specification A653 with the galvanized coating to ASTM specification A924.

Accessory Equipment

All accessory equipment should be installed and maintained in accordance with each individual supplier's installation and operation instructions. However, if any modifications to the Chief standard design are required, contact Chief for special recommendations.

Important Note: Do not modify the chain conveyor design without Chief approval. It is the responsibility of the general contractor to verify that all equipment is properly installed and that the equipment is compatible with the intended use. A qualified electrician should be contracted to complete all electrical wiring and servicing.

General Contractor Responsibilities

It is the responsibility of the general contractor to verify that the complete system (chain conveyor, and other accessory equipment) is constructed with quality workmanship and that all equipment is installed per the respective manufacturer's instructions.

In addition, the general contractor is responsible for the fitness of use of any system which he constructs. All accessory equipment incorporated into the system should be approved for the intended use by each respective equipment manufacturer.

Field Modifications and Installation Defects

Chief assumes no responsibility for field modifications or installation defects which result in structural damage or storage quality problems. If any field modifications are necessary which are not specifically covered by the contents of the installation manual, contact Chief for approval. Any unauthorized modification or installation defect which affects the structural integrity of the chain conveyor will void the warranty.

Checking Shipment

For your convenience individual items will be labeled with an appropriate part number and packages labeled. Hardware, including bolts, nuts, screws and other small clips or brackets may be divided into smaller packages for ease of use and identification.

Check your shipment at the time of delivery against the packing list provided with the shipment. If any items are missing or any damaged material is evident, note such shortage or damage on the freight bill before you sign the shipment paperwork.

Claims of shortages will not be honored after 30 days from receipt of shipment. Parts that are missing or damaged are the responsibility of the delivering carrier, not the manufacturer or dealer.

It is advisable to reorder damaged or missing parts immediately so that there will be no delay in the installation. After receiving the invoice for the reordered material, file a claim with the delivering carrier immediately.

Suggested Equipment

Chief recommends the following equipment and tools needed for installation. Individual installations may vary.

- Impact wrenches and sockets
- End wrenches
- Crescent wrenches
- Vise grip pliers
- Alignment punches
- Rubber mallets
- Level
- Drill and drill bits
- Screw Guns
- Metal Saw
- Extension cords

Hardware Torque

The following table contains recommended minimum and maximum torque values for installation.

When installing hardware the minimum and maximum torque values shown below must be followed. All hardware must seat tight against the corresponding bin component.

Bolt Diameter	Minimum Torque	Maximum Torque
5/16" (.79cm)	22 ft.-lbs.	28 ft.-lbs.
3/8" (.95cm)	25 ft.-lbs.	44 ft.-lbs.
7/16" (1.11cm)	60 ft.-lbs.	75 ft.-lbs.
1/2" (1.27cm)	50 ft.-lbs.	58 ft.-lbs.

Please note the following wrench / socket size to be used on the corresponding hardware:

Bolt Size	Head Size	Nut Size
5/16"	1/2" wrench	1/2" wrench
3/8"	9/16" wrench	9/16" wrench
7/16"	5/8" wrench	11/16" wrench
1/2"	3/4" wrench	3/4" wrench

Chain conveyor Safety

The following decals are installed at appropriate locations. Keep the decals clean at all times. If decals are no longer readable or missing they must be replaced. Contact Chief Industries for replacement decals.

Located on the belt guard cover:



Located on the fixed and cover and take up cover:



Pre-Installation Planning Information

Chain conveyors should be preplanned to meet the project requirements. Engineering drawings will simplify the installation and should include the following:

- Site layout
- Capacities
- Location and orientation of chain conveyor
- Location of accessories

The general installation of the chain conveyor components will be in the following order.

1. Install head section
2. Install intermediate sections
3. Install tail section
4. Install sumps and controller

Important Note: Never weld the conveyor to the support structures. Bolting allows for realignment of sections and replacement if necessary.

Use the following information to identify parts used during installation. Left hand head shaft projection is the standard configuration unless otherwise noted.

Under Floor Conveyor Design Specification Table									
Model	Standard Gauging			Optional Gauging		Available Chain		Chain Return	Max Outlet Size
	Side	Bottom	Cover	Bottom	Side Liner	81X	81X HD	Rail	
17x09	12	7 AR	14	.25 AR	10 AR	X	X	X	16"Sq
21x09	12	7 AR	14	.25 AR	10 AR	X	X	X	20"Sq

Under Floor Conveyor Chain and Paddle Specifications				
Model	81X (Paddles 10.4" O.C.)		81XHD (Paddles 10.4" O.C.)	
	10' Roll requires 12 Paddles		10' Roll requires 12 Paddles	
	Chain	Paddle	Chain	Paddle
17x09	9107601	9218586	9116702	9281394
21x09	9107601	9218586	9116702	9281394

Component Identification

Chief does not assume any responsibility from parts damaged due to faulty or improper installation procedures.

Horizontal and Horizontal/Incline Chain Conveyor

Take Up End with Sumps

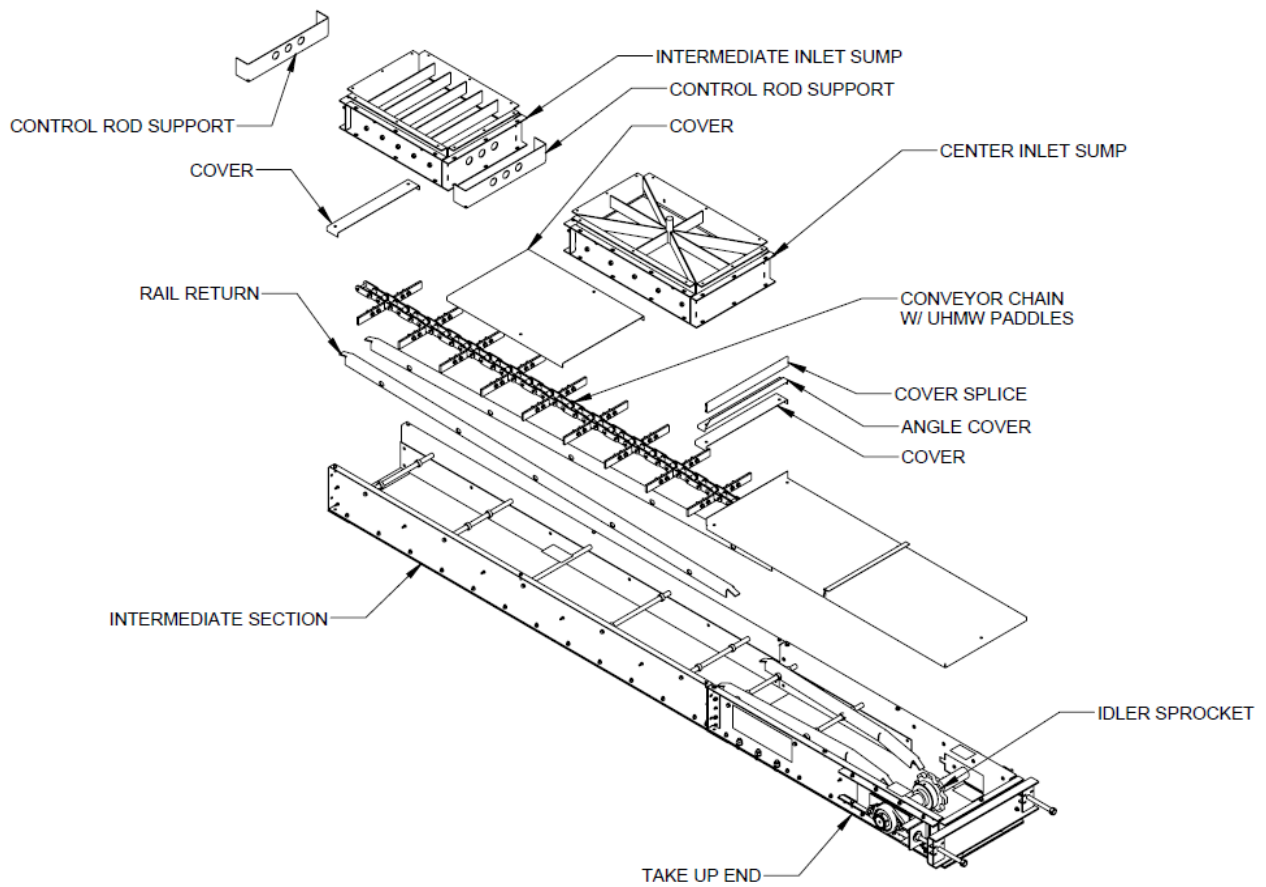

Horizontal Fixed End with Controller

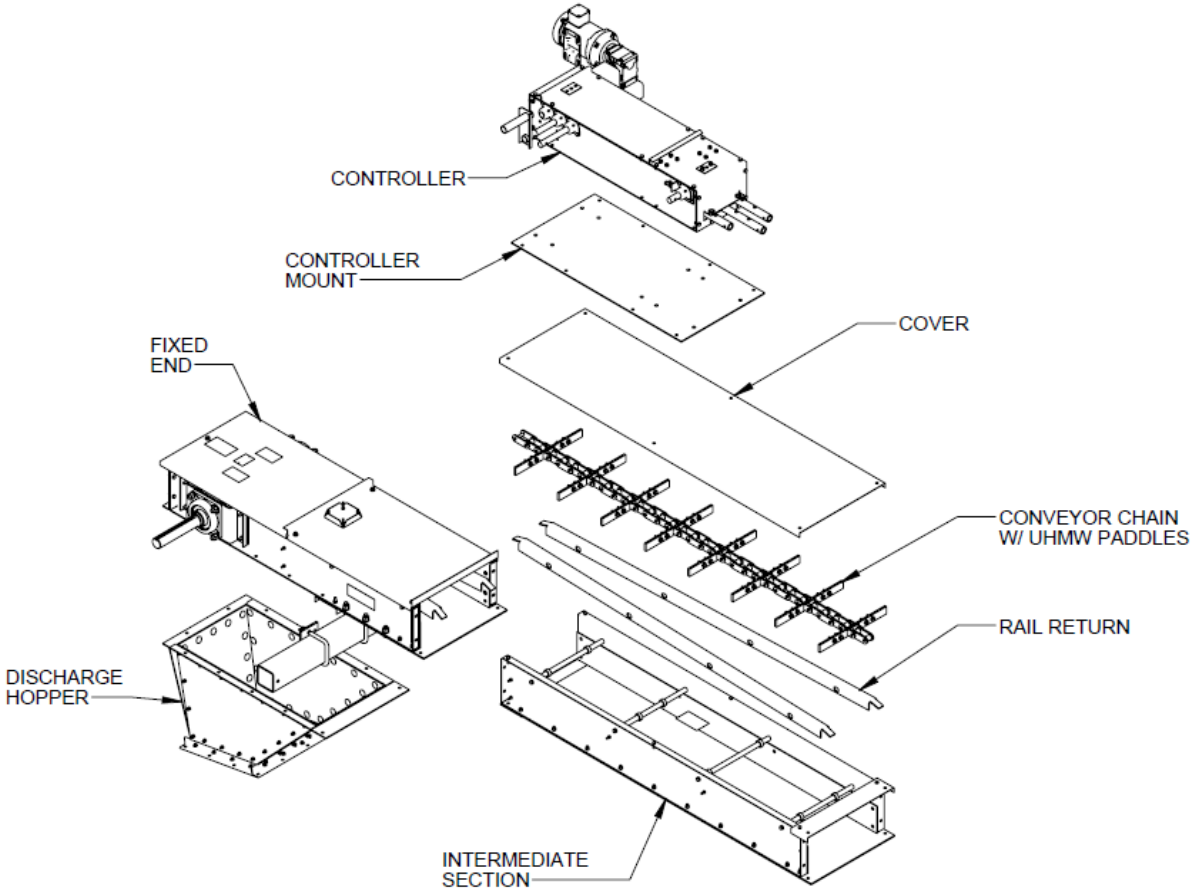

Inclined Fixed End with Controller

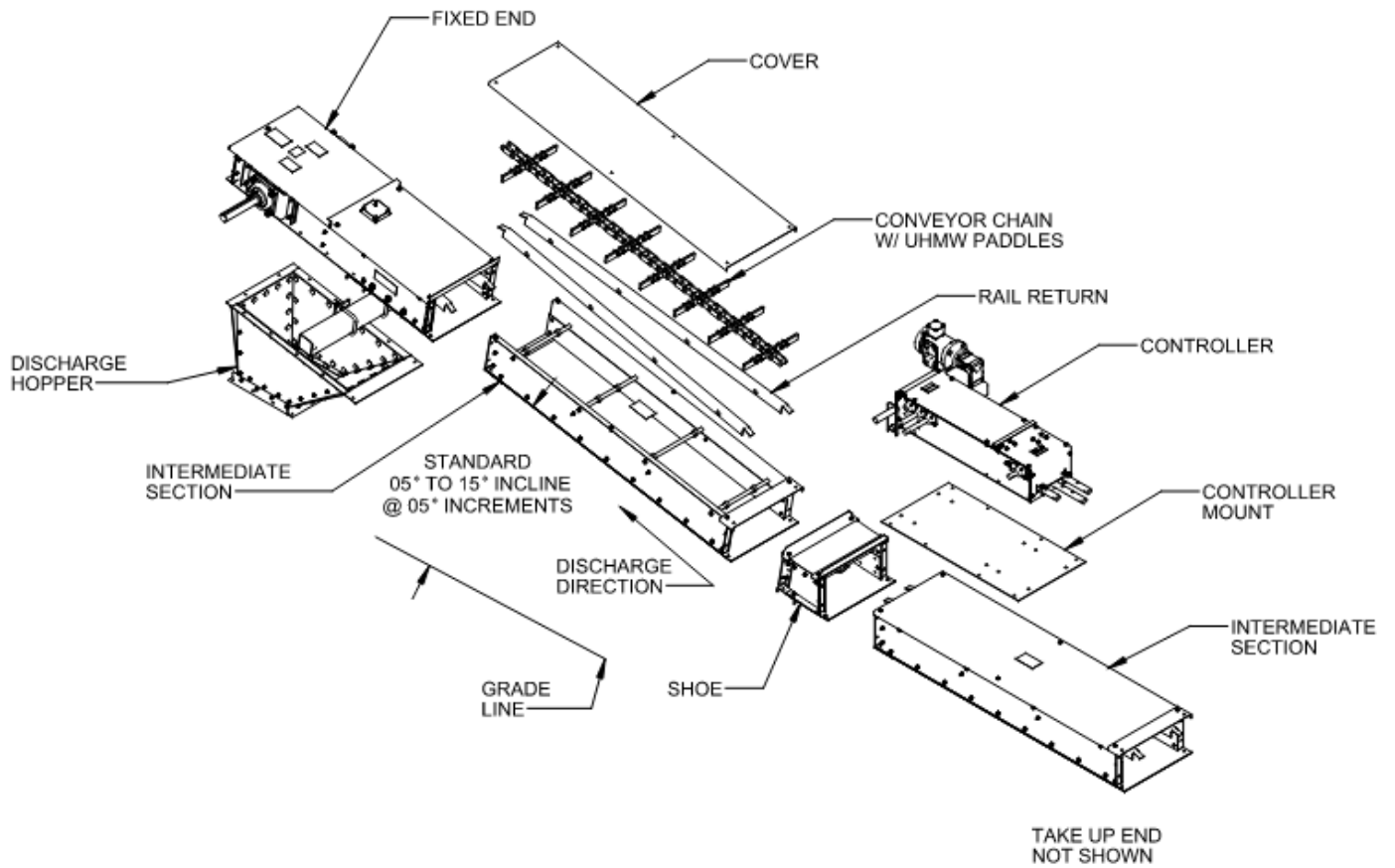

Component Installation

Horizontal Body Assembly

Important Note: Chain conveyor body assemblies may be shipped assembled or as separate components.

To assemble conveyor body sections, please take note of the following steps and corresponding illustrations.

Start by assembling the side panels to the bottom panels using 3/8" x 1" (.95cm x 2.54cm) hex head bolts and whiz nuts. Bolt heads will be located on the bottom of the conveyor. The bottom panel is offset from the side panels by 2.5" (6.35cm) as shown in the following illustration.

If liner panels are required assemble the liner panels at this time. Bolt heads will be located on the interior of the conveyor.

Before fully tightening hardware, leave out the end bolts and using drift pins align the holes, verify the 2.50" (6.35cm) offset and then tighten the unit. This will ensure that the unit will be square.

Install the return rails using 3/8" x 1" (.95cm x 2.54cm) bolts with lock washer. Bolt heads will be located on the exterior of the conveyor. Install the rail return bars and space them as shown in the following illustration.

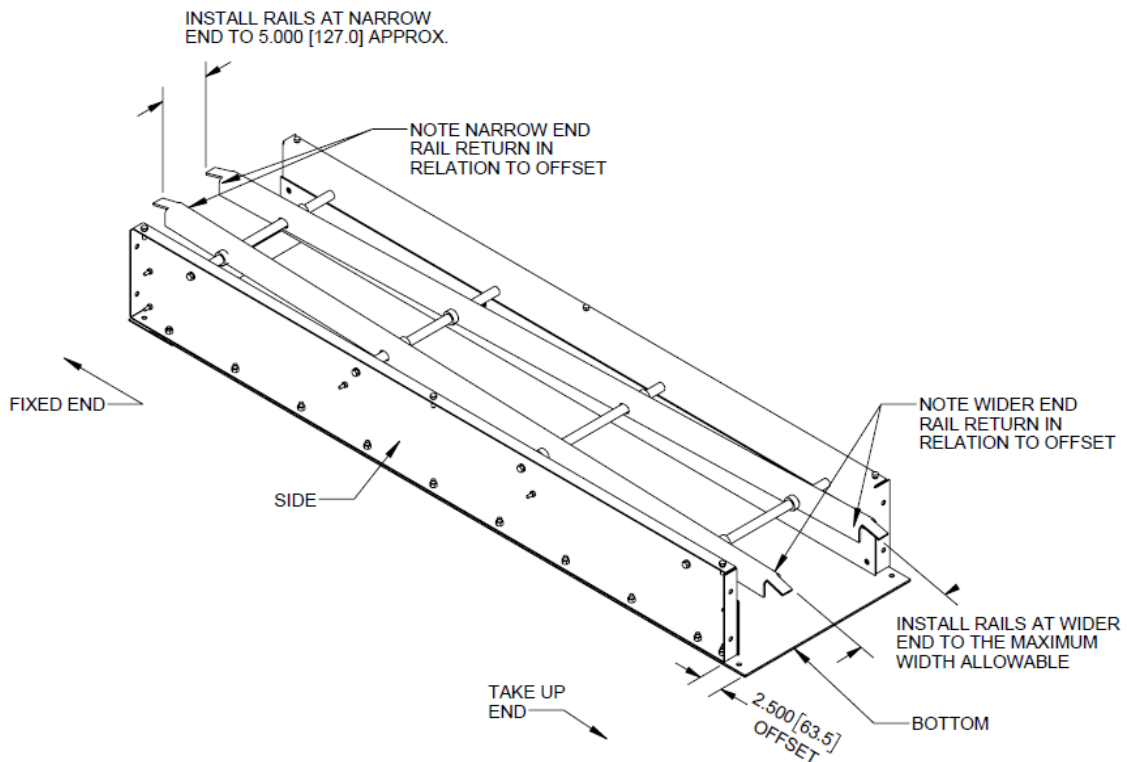

Start at the head section and connect the sections together at the bolted flanges using 3/8" x 1" (.95cm x 2.54cm) hex head bolts and whiz nuts. Complete the conveyor assembly leaving covers off for chain installation.

Bottom splices will already be attached to each intermediate section. Only hand tighten new connections at this time. Verify that all surfaces at the joint locations are flush.

Connect to the bottom splice using 3/8" x 1-1/4" (.95cm x 3.17cm) hex head bolts and whiz nuts. Bolt heads are to be located on the bottom of the conveyor.

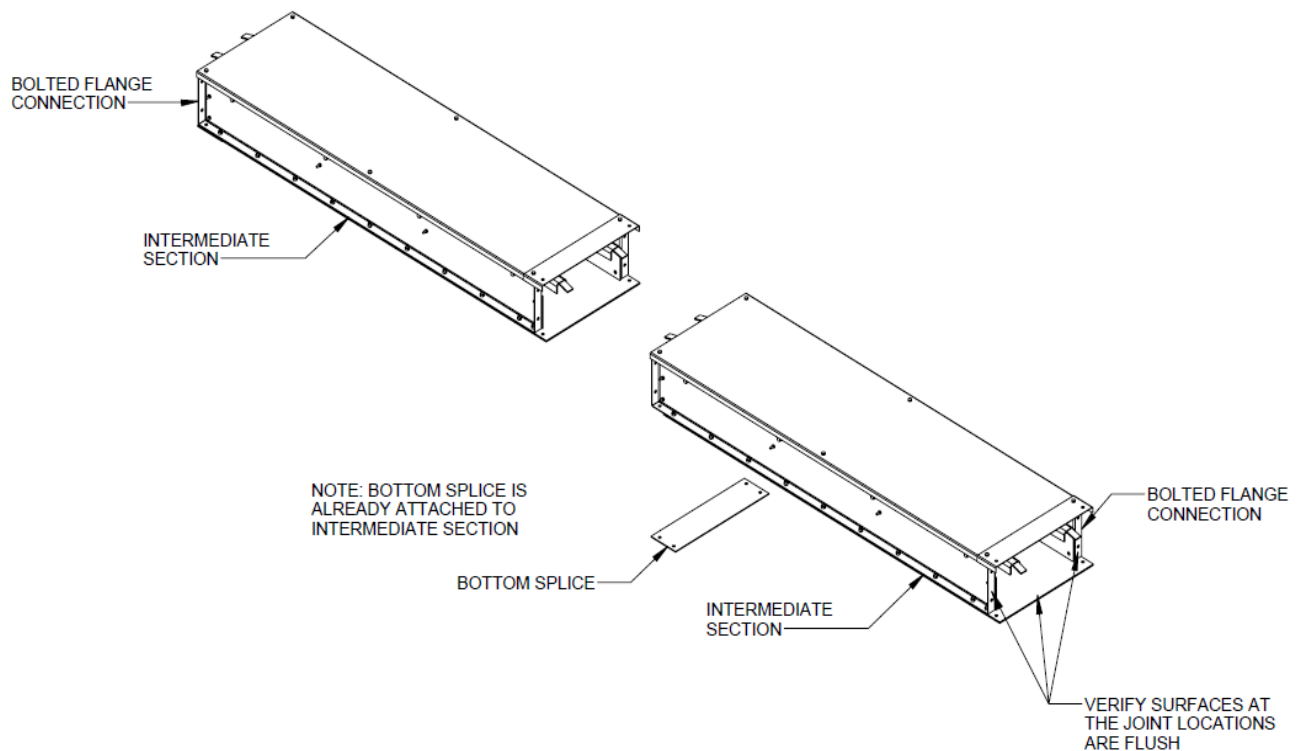

Chain Installation

Important Note: The chain may be installed at any time during the assembly process. The paddles are attached prior to the chain installation, with paddles bolted to every attachment.

Prior to the chain installation, install the paddles to each chain attachment using 5/16" x 1.25" (.79cm x 3.17cm) bolts and nylock nuts.

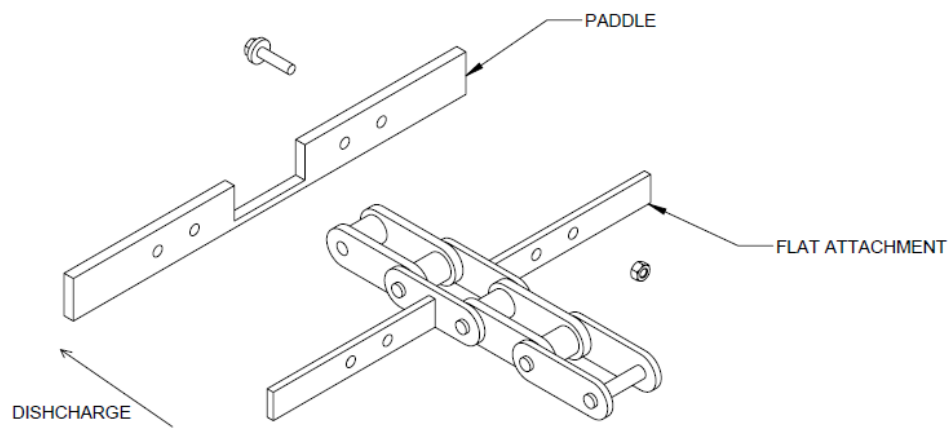

Chain Tension

The amount of chain tension required will vary with each conveyor. Conveyor capacity, conveyor length, characteristics of the conveyed product, and chain speed will factor into the chain tension required for a conveyor.

The chain tension will need to be tight enough so it does not jump a sprocket tooth or accumulate enough slack on the return side at the driven sprocket to cause the chain to catch an additional tooth as the chain continues to wrap around the sprocket.

Correct tension will prevent either a loose condition or excessive tension resulting in premature failure of the chain and sprocket.

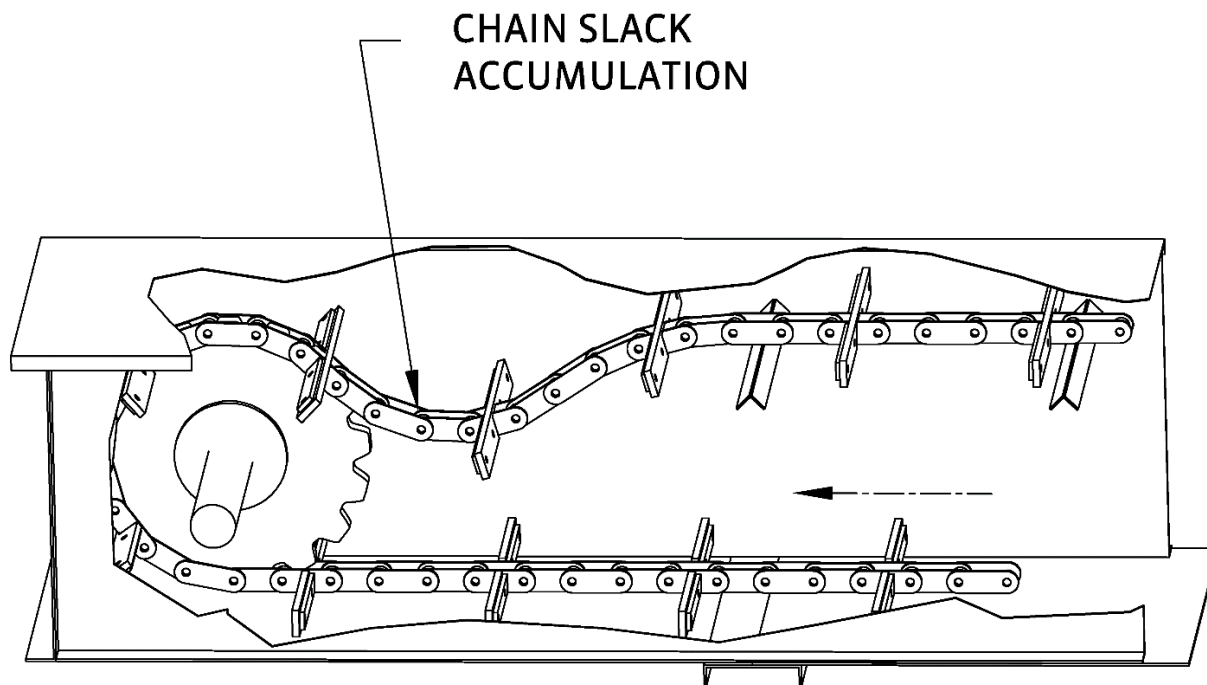

To tighten the chain, adjust the take up screws evenly to shorten the center distance between the conveyor shafts as shown in the following illustration. Eliminate the slack in the chain using a take-up device. Remove any extra chain links and rejoin chain. Then re-adjust the take-up screws evenly to achieve required chain tension. Once proper chain adjustment is achieved, torque the jamb nuts to prevent loosening of the chain.

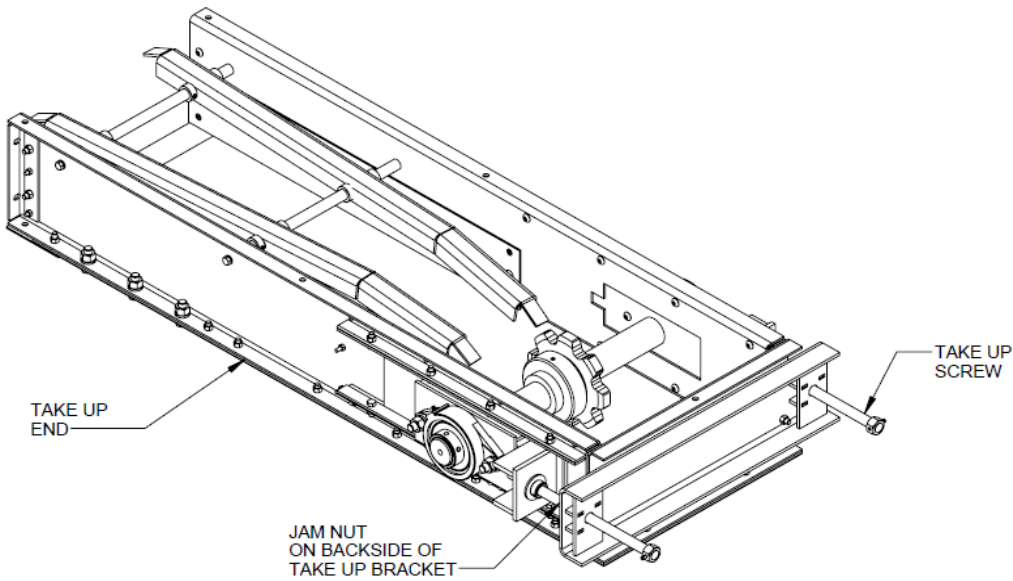
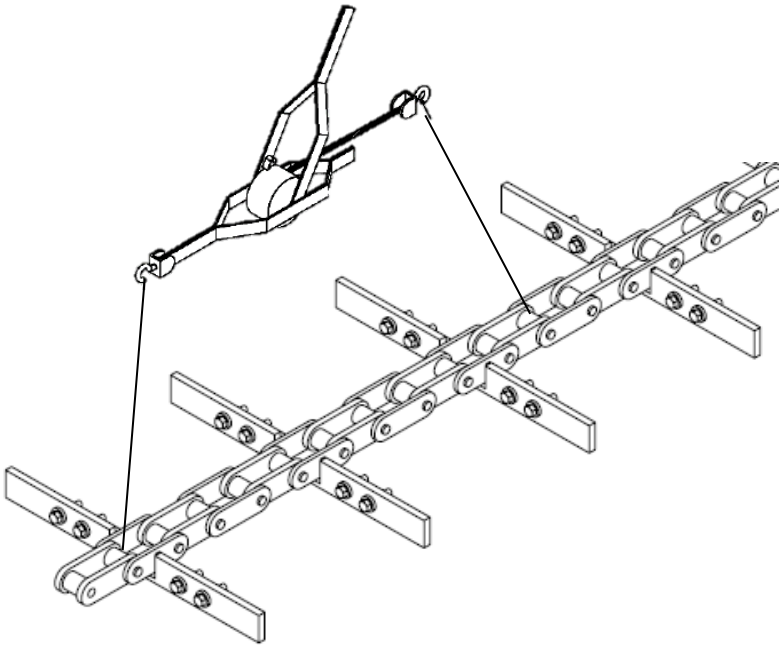

Drive Installation

Refer to the following illustration for orientation of components. Shown is a left hand configuration.

1. Install reducer drive that is packaged separately, according to the manufacturer's complete instructions.
2. Mount electric motor onto motor mount base
3. Move motor mount to align front of motor with front of reducer.
4. Install torque arm
5. If required install optional fan kit according to manufacturer's directions.
6. Install belt guard according to manufacturer's directions.
7. Install sheaves leaving clearance between back of sheaves and front of motor and reducer for belt guard installation.
8. Install v-belts and adjust motor mount base to tighten belts.
9. Install belt guard / reducer bracket.

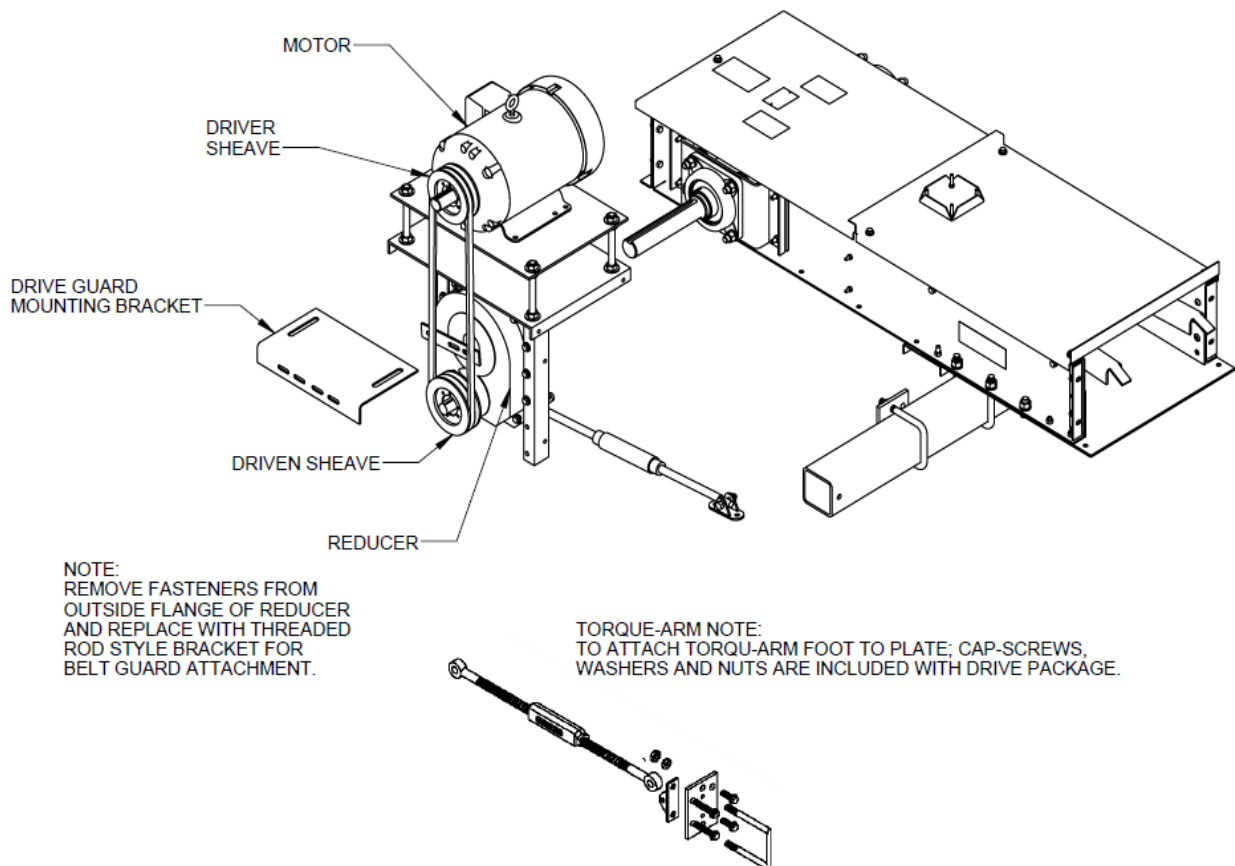

Important Note: Reducer drives are shipped without lubricant. Do not operate the chain conveyor until the reducer drive has been filled with an approved lubricant as described in the manufacturer's instructions.

Position the motor on the fixed end motor mount and attach with the bolt package provided. Adjustment to the motor mount may be required so that the end of the motor shaft is in line with the end of the reducer input shaft.

Install the drive belts and adjust belt tension. Using a belt tension checker adjust the belts so that a force in the middle of each belt will deflect the belt $1/64$ " for each inch of distance between the sheave centers.

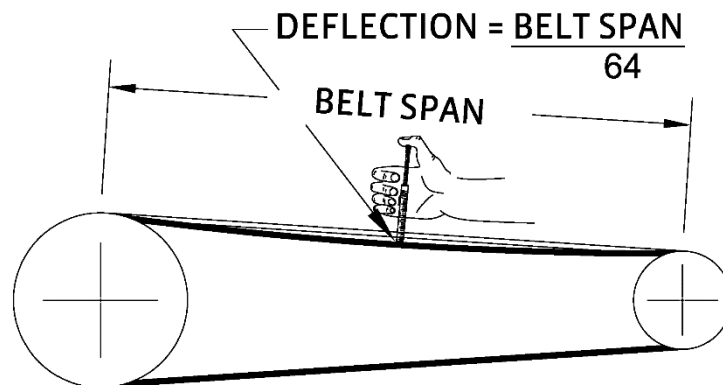

Important Note: Compare the force you have applied with the values in the following chart. The force should be between the minimum and maximum shown. The maximum value shown is for a “New Belt”, and new belts should be tensioned at this value to allow for expected tension loss. Used belts should be maintained at the minimum value.

Cross Section	Smallest Sheave Diameter Range (in)	RPM Range	Belt Deflection Force (lbs)			
			Super Gripbelt		Gripnotch Belt	
			Min	Max	Min	Max
3V	2.2-2.4	1000-2500	-	-	3.3	4.9
		2501-4000	-	-	2.9	4.3
	2.65-3.65	1000-2500	3.6	5.1	4.2	6.2
		2501-4000	3.0	4.4	3.8	5.6
	4.12-6.90	1000-2500	4.9	7.3	5.3	7.9
		2501-4000	4.4	6.6	4.9	7.3
5V	4.4-6.7	500-1749	-	-	10.2	15.2
		1750-3000	-	-	8.8	13.2
		3001-4000	-	-	5.6	8.5
	7.1-10.9	500-1740	12.7	18.9	14.8	22.1
		1741-3000	11.2	16.7	13.7	20.1
	11.8-16.0	500-1740	15.5	23.4	17.1	25.5
		1741-3000	14.6	21.8	16.8	25.0

The ideal tension is the lowest tension at which the belt will not slip under peak load conditions (over tensioning shortens belt and bearing life). Check tension frequently during the first 24 hours to 48 hours of operation.

Important Note: All sheaves, sprockets, and drive components assembled at the manufacturer (including the chain conveyor pulley) should be checked for alignment, centered and tightened prior to operation and at regular operating intervals.

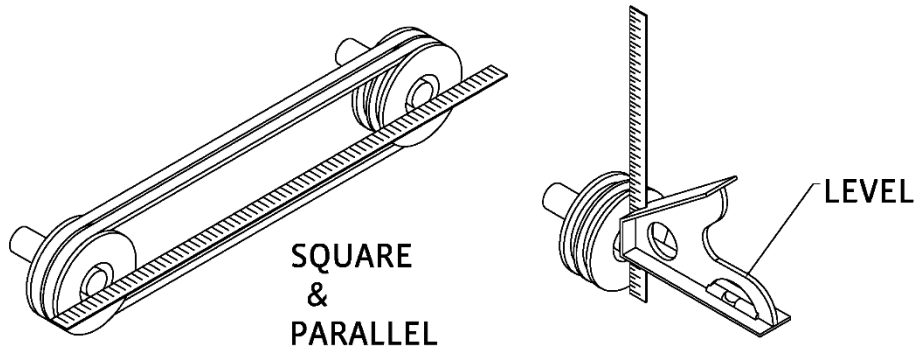

Install the belt guard and drive components. Since configurations and bracketing of belt guards differ per model and reducer drive, refer to the supplemental drawings shipped with the drive package for installation instructions on your specific model. Install the belt guard back panels and bracketing. Adjust the belt guard bracketing to allow for back panel clearance away from motor & reducer. Install sheaves and belts allowing for clearance away from back panels. Complete the installation by placing belt guard shell over the sheaves and belts and then attaching the shell to the back panels

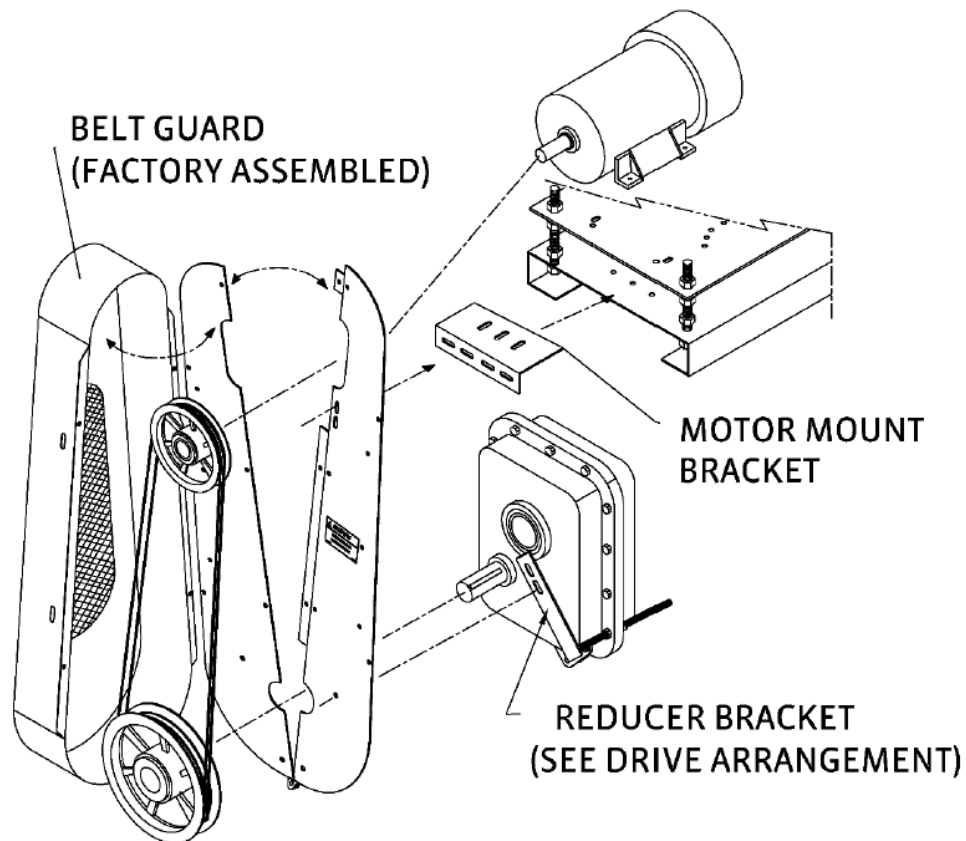

Important Note: Do not operate the chain conveyor without a correctly installed belt guard assembly.

Important Note: Explosion proof electrical equipment must be used whenever a chain conveyor is located in an explosive environment. A safety switch should be installed on the fixed end section to prevent accidental motor operation when servicing any components.

Inlet Gate Installation

1. Determine bin center for center gate location.
2. Mark gate centerline on conveyor cover(s).
3. Locate intermediate gates as desired and mark gate centerline on conveyor covers.
4. Remove and cut conveyor covers according to table below (for center gate and all intermediate gates).
5. Using gate as template mark and drill mount holes in top flange of conveyor side panels.
6. Re-install conveyor covers
7. Install gates using 3/8" x 1" (.95cm x 2.54cm) bolts and nuts.
8. Determine location of control rod support bracket according to table below and install.
9. Install controller and control rods (see controller installation steps).
10. Install floor supports (see floor support addendum) and the gate inlet.

Gate Type	Nominal Gate Length	A Dimension	B Dimension	C Dimension
Center	30"	15-1/2"	31"	30-1/16"
Intermediate	24"	12-1/2"	25"	24-1/6"

CHAIN CONVEYOR

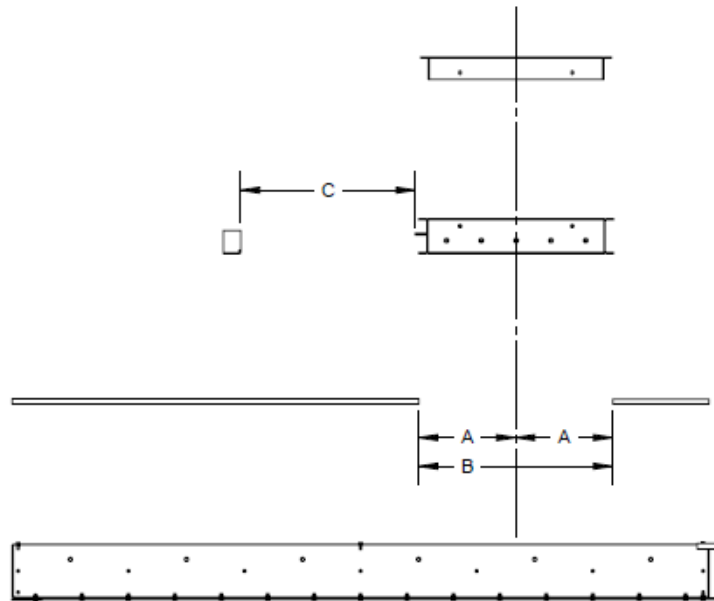
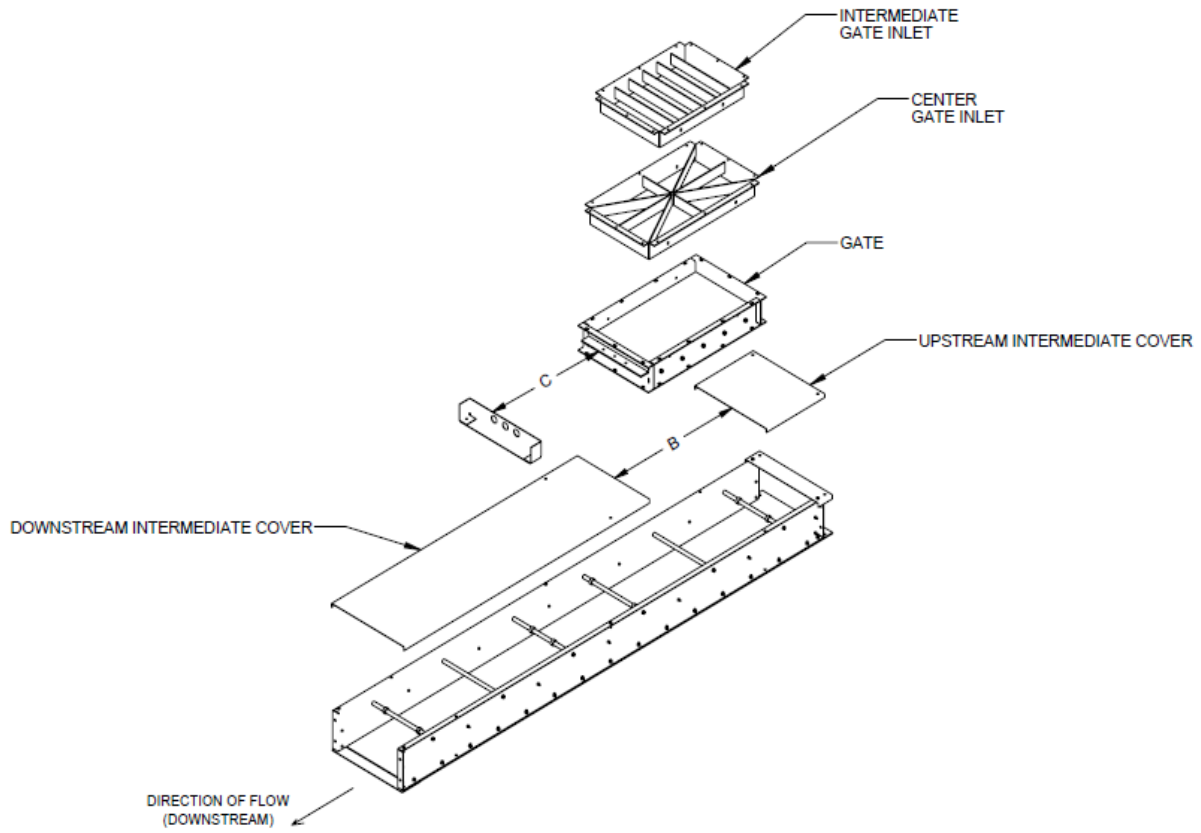

Controller Installation

1. Insert control rods through bin sidewall flashing and supports/gates on top of conveyor. Splice as needed using a coupler with 5/16" x 2" (.79cm x 5.08cm) bolts and nuts.
2. Controller will be located between bin sidewall and conveyor shoe if inclined, or fixed end if there is no incline.
3. Attach controller to mounting plate using 3/8" x 1" (.95cm x 2.54cm) flat head bolts and nuts.
4. Install controller with mounting plate to top of conveyor using 3/8" x 1-1/4" bolts and nuts through conveyor cover and top flange.
- a. Cut control rod lengths sufficient to reach from controller to center of gate openings. push rods into bin to allow clearance for controller installation.
5. Attach control rods to controller brackets using 5/16" x 2" (.79cm x 5.08cm) bolts and nuts.
6. Ensuring controller is in closed position, drill center control rod and bolt center gate slide using 5/16" x 2" (.79cm x 5.08cm) bolts and nuts.
7. Drill and bolt first intermediate gate slide to second control rod using 5/16" x 2" (.79cm x 5.08cm) bolts and nuts.
8. Drill and bolt all remaining intermediate gate slides to third control rod using 5/16" x 2" (.79cm x 5.08cm) bolts and nuts.

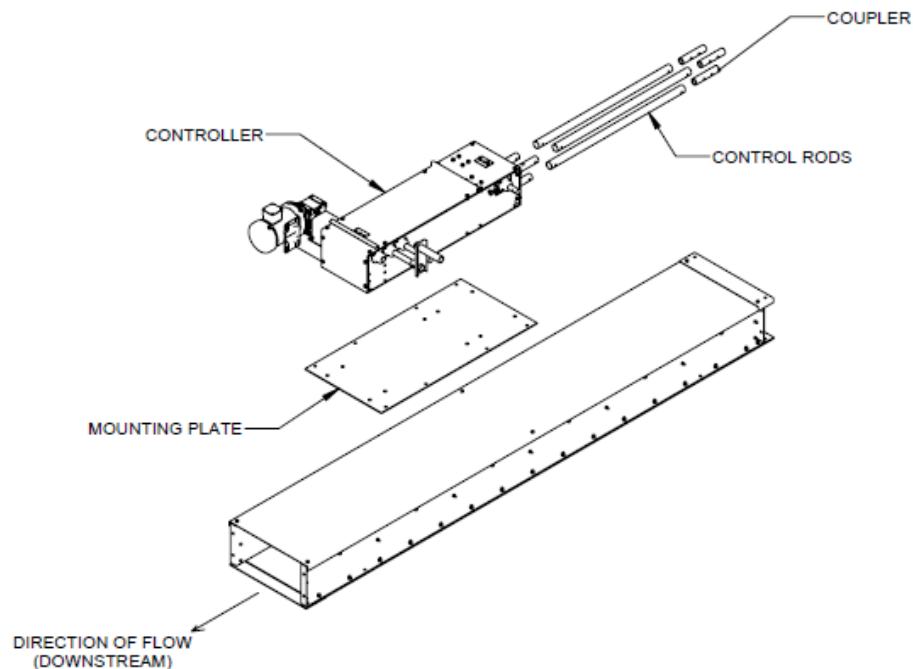

CHAIN CONVEYOR

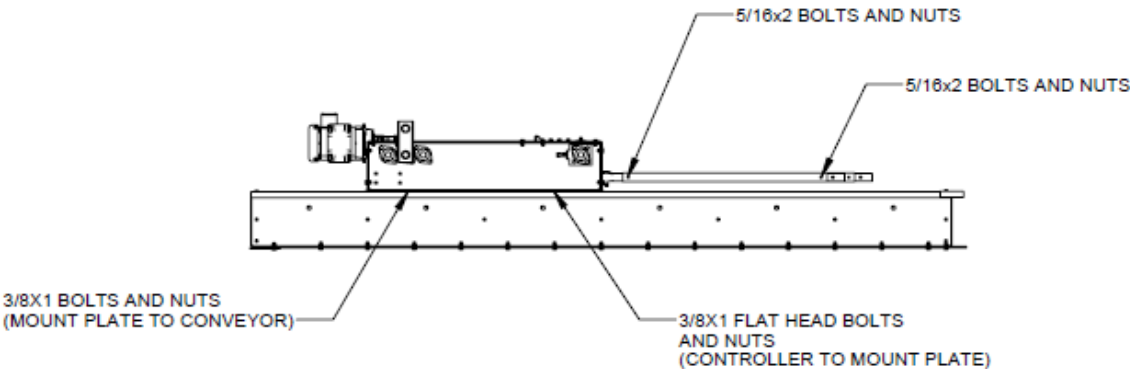

Bin Flashing Installation

1. Cut conveyor opening in bin sidewall (recommended as depicted in table below).
2. Flashing is to be installed before gate control rods are installed.
3. Apply sealant to mating sides of each flashing piece.
4. Install right hand and left hand flashing and bring mating sides flush with conveyor.
5. Install top flashing into location.
6. Completely fill all gaps between conveyor flashing and bin sidewall.
7. Use 1/4x1-1/4 tek screws on all holes. Do not drill screws into conveyor.

NOMINAL CONVEYOR WIDTH	A DIMENSION
17"	23"
21"	27"

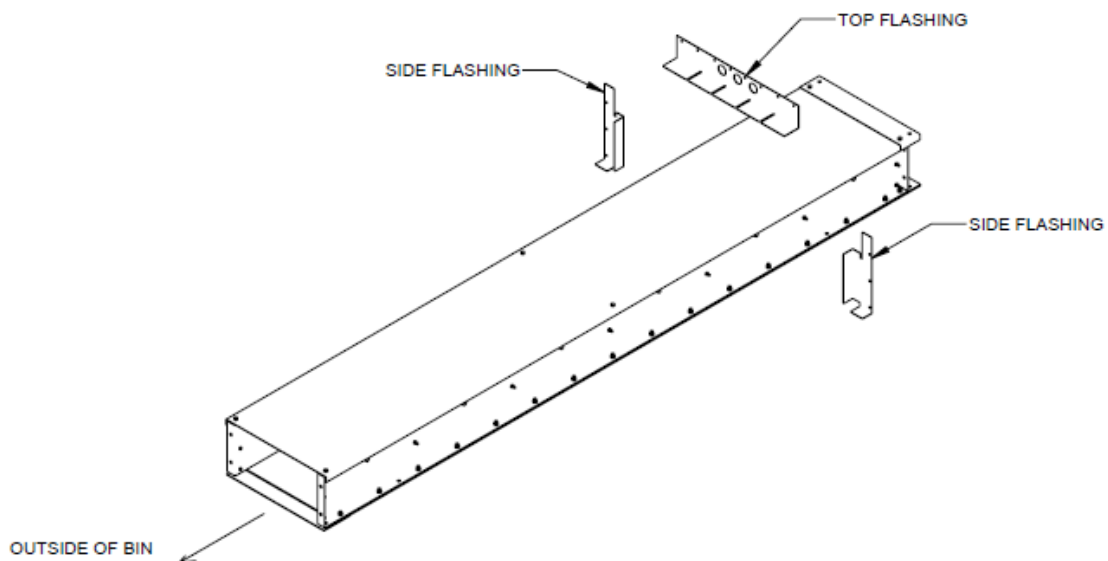

CHAIN CONVEYOR

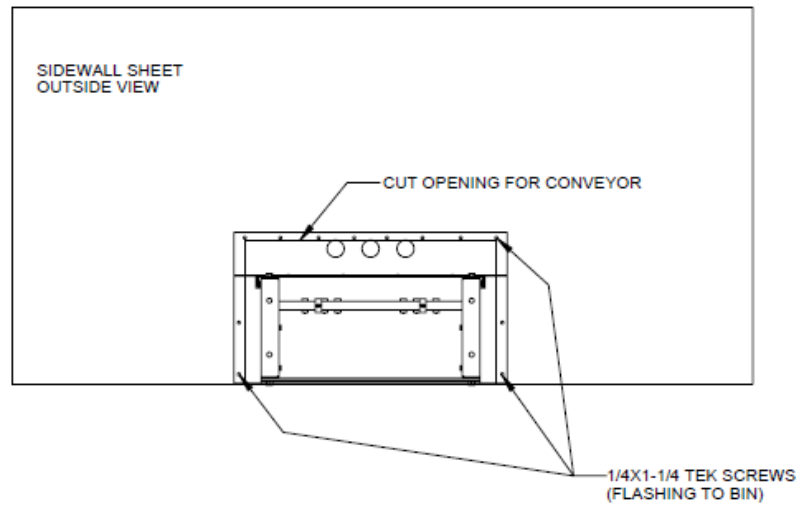
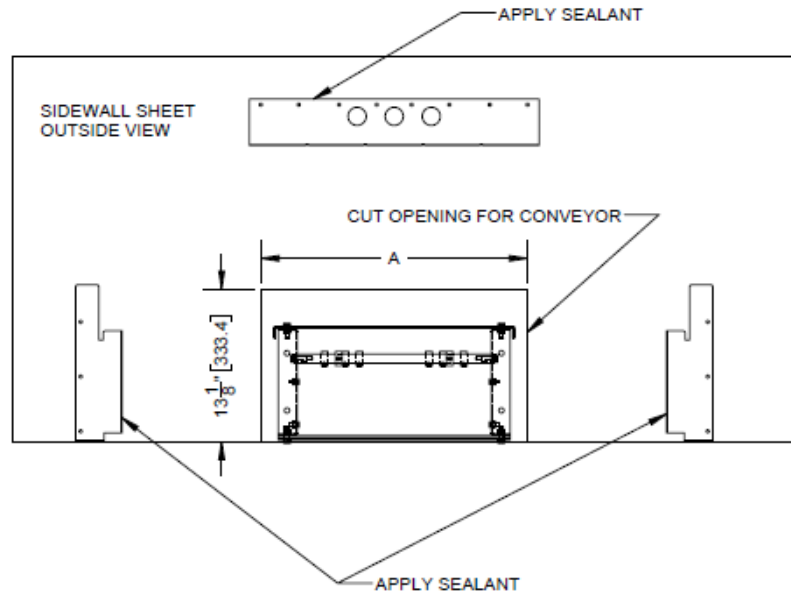

Floor Support Installation

General Notes

- Complete installation of UFC, UFC gates, UFC control system prior to floor installation
- See standard floor installation detail for standard support spacing and channellock plank details
 - Standard layout supports located within conveyor area to be shifted outside airframes

Install Airframe Supports

1. For the 17 wide, locate airframes 12" each side from bin/conveyor centerline
 - a. For 21 wide, locate airframes 14" each side from bin/conveyor centerline
2. Place airframes end-to-end along full length of UFC
3. Final airframe will require field cutting to length
 - a. Use drop piece from first side to complete second side if of sufficient length

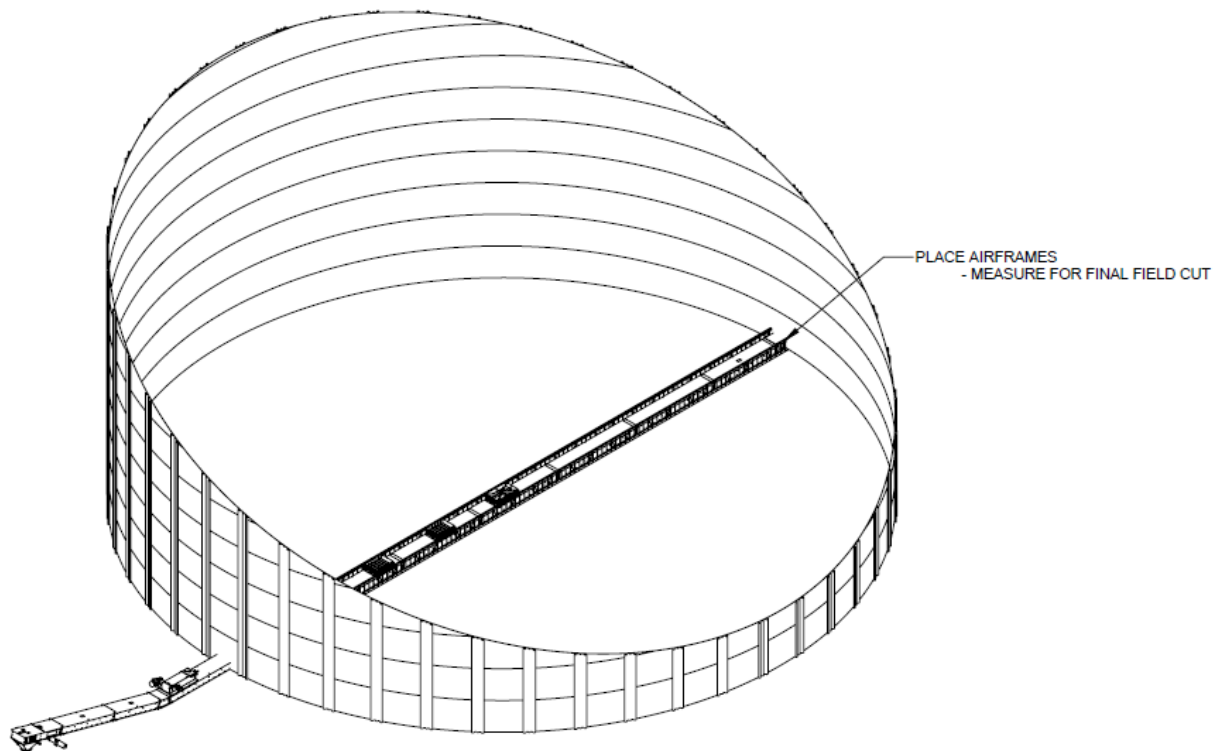

Install Floor Support Tubes and Floor

1. Install floor support tubes centered under each channellock across airframes as floor is built per standard layout.
2. Move stamped supports that interfere with conveyor or airframes out from centerline of bin to clear airframe supports. **Do not exceed maximum support spacing listed on standard floor installation details.**
3. As floor is built omit tube supports at gate locations and allow channellock planks to sit on gate frame.
4. Trim channellock planks to match gate openings.
5. Install gate inlets on top of channellock planks. Use 3/8" (.95cm) bolts to gate frames and tek screws to channellock planks.

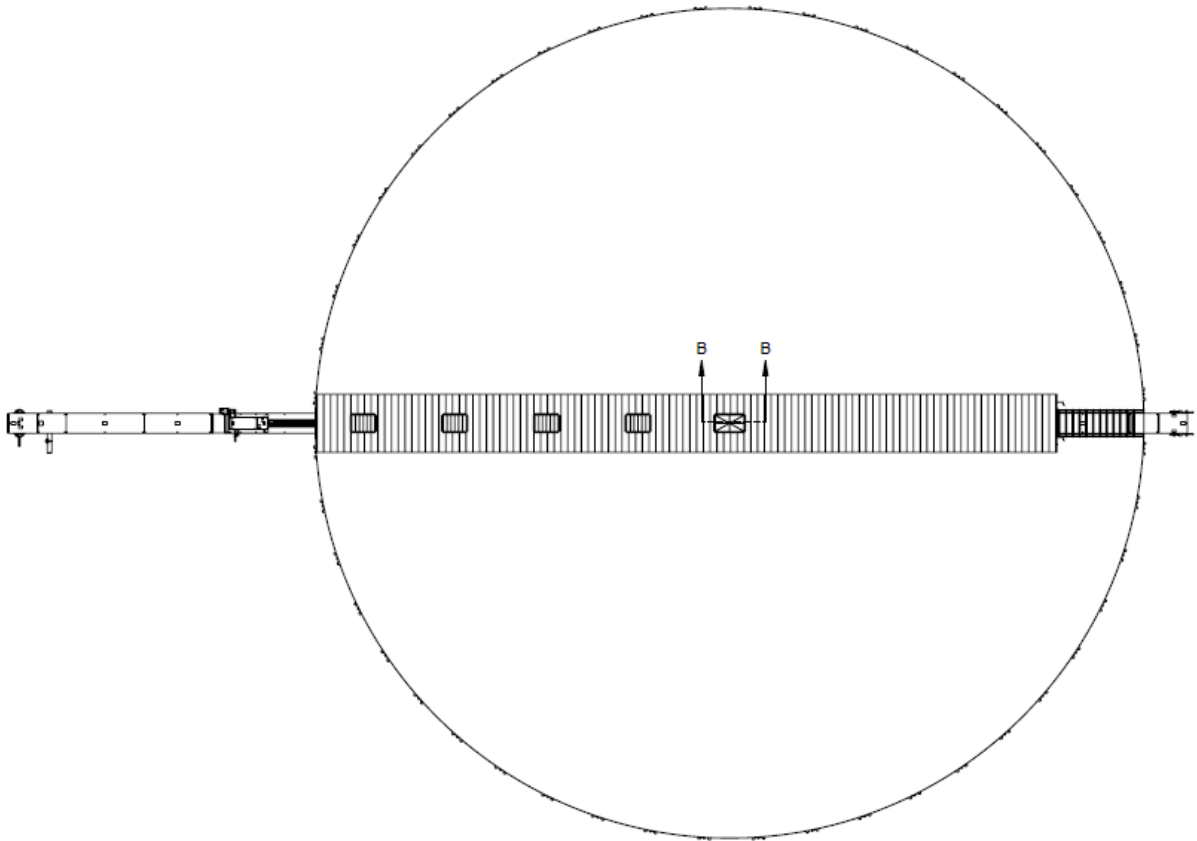

Slack Chain Sensor Installation

WARNING! MOVING CHAIN CAN CAUSE INJURY! DO NOT PUT HAND INTO CONVEYOR WHILE CHAIN IS IN MOTION! FOLLOW PROPER LOCK-OUT PROCEDURES!

1. Shut off and lock out all power sources to conveyor. Ensure chain is NOT in motion.
2. Remove fixed end removable cover and slack/broken chain cover. Do not let bolts fall into conveyor.
3. Check conveyor chain for proper tension. If required, adjust take-up.
4. If chain adjustment is required, after adjustment replace all covers and run conveyor sufficient to allow chain to equalize tension through conveyor length.
5. Repeats steps 1-4 as needed.
6. When proper tension is achieved, with power sources locked out and covers removed, use 1/4x 1-1/2 screws and nuts to mount sensor to cover in provided location.
 - a. Mount with nut on top of the mounting bracket/bolt heads inside conveyor box to ensure paddle clearance.
7. Replace conveyor covers and restore power to conveyor.

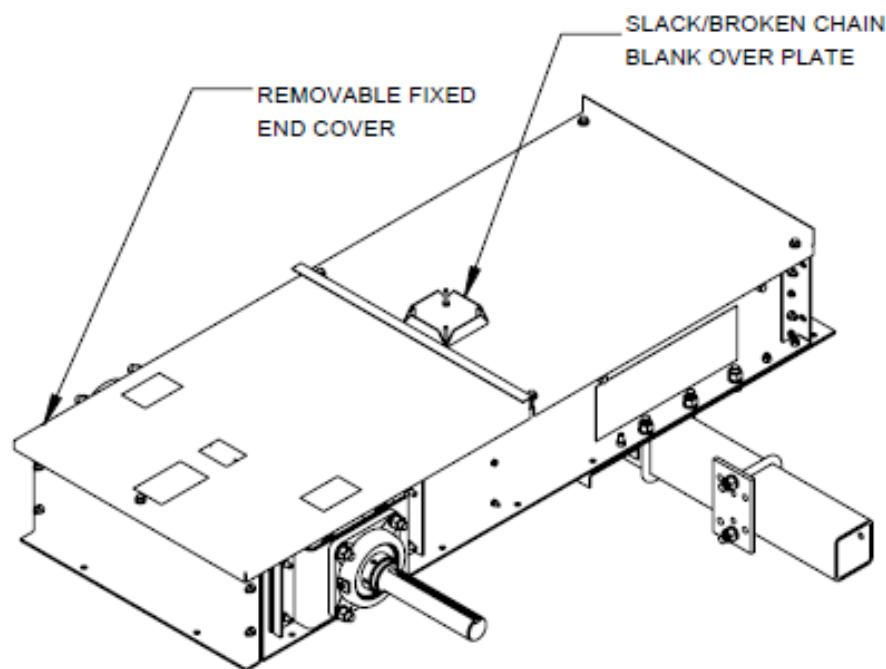

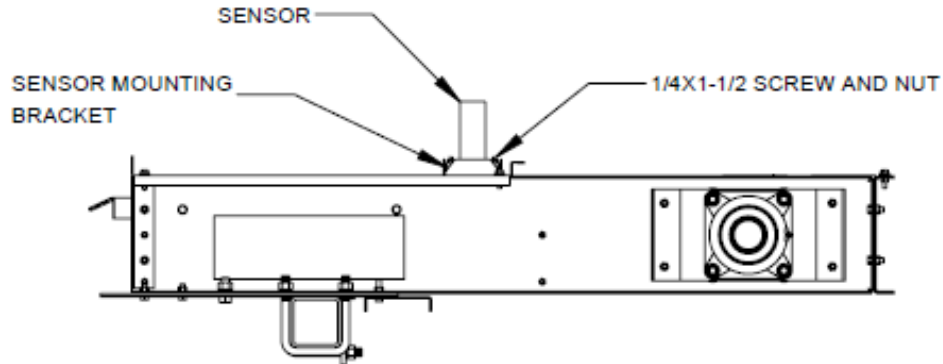

ADJUSTING SLACK/BROKEN CHAIN SENSOR

1. Adjust sensor depth (Dimension A below) by loosening the adjustment bolt on the mounting bracket, sliding the sensor to the required depth and retightening the bolt.
2. Begin with sensor flush with the bottom of the mounting bracket. Apply power to run conveyor chain. If LED light is no blinking on speed relay, slide sensor down towards chain slowly until the light begins to blink.
3. If light is blinking, leave sensor flush with bottom of mounting bracket. **Do NOT allow the sensor to come into contact with the chain or paddles.**
4. Re-attach removable fixed end cover.

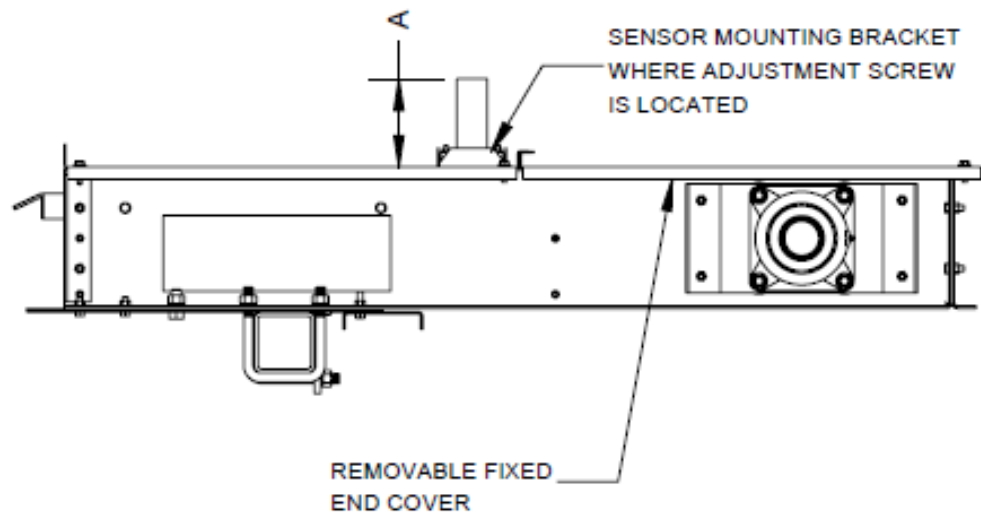

SENSOR CALIBRATION

Once sensor is at required depth, adjust sensitivity screw:

1. Turn screw fully clockwise while machine is running. The green LED should flash.
2. Slowly turn the screw counter-clockwise until the flashing becomes irregular.
3. Turn screw clockwise until the LED flashing pattern becomes regular.
4. Add an extra 1/8th clockwise turn for range compensation.

TESTING

1. See wiring diagram in sensor operation manual in Manufacturer Data/Recommendation section below to check that unit is correctly installed.
2. Startup conveyor. The green LED shows the state of pulsed output and will flash once for each target detected. It will not flash when a target is not detected.
3. Check and re-adjust conveyor, and slack/broken chain sensor if needed, after 20 hours of run time.

Start up and Operation

Prior to operating the conveyor, check all areas for safety issues and machine damage which could occur during operation. Follow all manufacturers' pre-start up instructions for each individual component provided with your conveyor. In addition verify the following:

- All debris is removed from the conveyor.
- Conveyor sections are properly aligned and square
- Return rails and idler rollers turn freely
- Paddles do not interfere with sides of conveyor
- All hardware is in place with correct torque
- Drive and take up sprockets are centered across the width of the conveyor and square with the conveyor housing
- Secure set screws in bearings, drive sheaves, head and tail shafts, and gear reducers and drive sprocket key is secured in place
- Sheaves properly aligned and V-belts properly tensioned
- Bushing bolts in sheaves and reducer are torqued to manufacturer specifications
- Chain tension is correct
- Drive guard and other safety devices installed
- Inspection section panels in place and properly secured
- Discharge area free of obstructions
- Reducer installed to manufacturer specifications
- Reducer has lubricant and is filled to proper level
- Safety restrictions on electric controls
- Electrical equipment is installed to meet national electric code and/ or local safety codes, including explosion proof equipment where required

After an initial pre-start inspection, operate the chain conveyor empty under power for a period of time to verify the chain is tracking correctly on the sprockets and idlers. If there is excess slack in the chain, adjust the take up evenly. Monitor the belts and sheaves for correct belt tension and sheave alignment.

Verify all gates and accessories for proper operation and monitor conveyor for unusual operation. Complete any necessary adjustments and verify all covers are installed correctly.

To complete a conveyor system, material feed and discharge connections must be made to the chain conveyor. Complete these connections prior to placing the chain conveyor into service.

Since the conveyor has been previously operated without material, it may now be tested under load. It is suggested that the flow systems be verified next. Allow only a small amount of material to enter the conveyor while it is running. Verify that the material can flow through the system connections, gates, etc. for proper operation. Once all flow paths have been verified, the conveyor may be gradually loaded to capacity. When the conveyor is operating at full capacity verify the following:

- Correct movement of material
- Electrical current draw on the motor (amperage)

After the first 8-10 hours of operation inspect the following:

- Verify all bolts attached to the paddles are tight.
- Verify that the tracking of the chain is correct.
- Check the drive components for correct tight fit (drive, sprockets, belts, chains, torque arm).
- Check gear reducer for overheating or oil leakage.

Set Screw Diameter	Socket Size	Ball Bearing Torque		Roller Bearing Torque	
		In.-lb.	Kg.-M.	In.-lb.	Kg.-M.
#10	3/32"	30	.3	-	-
1/4"	1/8"	70	.8	-	-
5/16"	5/32"	140	1.6	125	1.4
3/8"	3/16"	220	2.5	225	2.6
7/16"	7/32"	350	4.0	325	3.7
1/2"	1/4"	-	-	475	5.5
5/8"	5/16"	-	-	1150	13.2
3/4"	3/8"	-	-	1600	18.4

Important Note: Some elongation of the chain will occur after the chain is in operation. The elongation will occur over the life of the chain. There will be some elongation in the first few hours of operation as the chain seats itself. Check the chain after the first hour of operation, then daily for the first week of running operation, making adjustments as necessary. Continue with checks as recommended in periodic maintenance section. As the conveyor is operated it will probably become necessary to remove one or more of the chain links as the chain elongates to the extent that the take-up travel has been used up.

Important Note: Monitor operating bearing during the first 48 hours for unusual vibration or temperature. Operate bearings under full load for several days to permit seating of bearing and sleeve on the shaft then shutdown the system and re-tighten lock nuts on all bearings.

Periodic Maintenance

The following are guidelines for maintaining the conveyor. Operators will have to determine what inspection and service intervals are necessary for their application. Factors to consider are the frequency of operation and the operating environment of the equipment.

1. Daily
 - a. Always be aware of the normal operating sounds. If any abnormal sounds occur, stop the conveyor, find the source of the noise, then lock out power to conveyor and repair the problem.
2. Weekly
 - a. Lubricate bearings according to manufacturer specifications.
3. Monthly
 - a. Check V-belt tension and overall condition. Replace if worn, frayed, or cracked.
 - b. Check that set screws in pulleys and bearings are tight. If necessary tighten to manufacturers' specifications.
 - c. Check for missing or damaged paddles. Replace if necessary. Check paddle bolts for tightness. Check attachments to chain. If attachments are slightly bent and do not appear to be in danger of separating from the chain and the attachments are not having an adverse effect upon the capacity, replacement is not necessary.
 - d. Check that the conveyor chain is properly tensioned and is tracking correctly.
 - e. Check oil level in gearbox and inspect seals for signs of leakage. Follow manufacturer's specifications for oil level and oil change periods.
 - f. Check that the motor is clean and properly ventilated.
 - g. Lubricate motor according to manufacturer's specifications and intervals.
4. Quarterly
 - a. Check all conveyor components for loose or missing fasteners.
 - b. Check safety guards for interference with moving parts.

Troubleshooting

Items shown below are an aide to troubleshooting when a problem is encountered. Some causes can be corrected by reviewing certain areas of the assembly instructions. When checking conveyor capacities, note that rated capacities are calculated using 75% cup fill.

1. Problem: Measured capacity is reduced from the rated capacity
 - a. Possible cause: Incorrect shaft RPM
 - i. Possible reason or solution
 1. Undersized reducer
 2. Incorrect sheave orientation
 - b. Possible cause: Loose chain
 - i. Possible reason or solution
 1. Incorrect chain speed
 - c. Possible cause: Incorrect feed
 - i. Possible reason or solution
 1. Incorrect grain flow at inlet
 - d. Possible cause: Conveyor incline level
 - i. Possible reason or solution
 1. 5% maximum incline level
 - e. Possible cause: Conveyor plugging
 - i. Possible reason or solution
 1. Check and clear discharge opening
2. Problem: Noisy operation
 - a. Possible cause: Loose paddles
 - i. Possible reason or solution
 1. Tighten or replace fasteners
 - b. Possible cause: Conveyor bottoms not aligned
 - i. Possible reason or solution
 1. Check intermediate bottom joints and verify they are flush
 - c. Possible cause: Damaged chain attachments
 - i. Possible reason or solution
 1. Replace attachments
 - d. Possible cause: Worn idler roller or rail return
 - i. Possible reason or solution
 1. Replace components
 - e. Possible cause: Drive components
 - i. Possible reason or solution
 1. Check oil level
3. Problem: Uneven paddle wear
 - a. Possible cause: Conveyor misalignment
 - i. Possible reason or solution
 1. Align conveyor sections from head to tail

- b. Possible cause: Sprocket slipped
 - i. Possible reason or solution
 - 1. Check set screws on sprocket.
 - 2. Center and square sprocket in opening and tighten set screws
- 4. Problem: Excessive carry-over of material
 - a. Possible cause: Chain riding over material
 - i. Possible reason or solution
 - 1. Verify maximum incline is not above 5%
 - b. Possible cause: Gates not fully open
 - i. Possible reason or solution
 - 1. Check gate operation
- 5. Problem: Uneven sprocket wear
 - a. Possible cause: Worn chain
 - i. Possible reason or solution
 - 1. Replace chain
 - b. Possible cause: Incorrect sprocket alignment
 - i. Possible reason or solution
 - 1. Center and square sprocket in opening and tighten set screws

Manufacturer Data / Recommendations

The following pages have been provided to assist our customer during maintenance of components that have been factory installed on your Chief Under Floor Conveyor.

Dodge S-2000 Spherical Roller Bearings

**INSTRUCTION MANUAL FOR
DODGE®S-2000 SPHERICAL ROLLER BEARINGS**

These instructions must be read thoroughly before installing or operating this product.

WARNING: To ensure that drive is not unexpectedly started, turn off and lock out or tag power source before proceeding. Failure to observe these precautions may result in bodily injury.

INSTALLATION

GENERAL INFORMATION

DODGE S-2000 Spherical Roller Bearing mounted units incorporate a unique way of sealing the internal components of the bearing while still allowing a full + or - 1 degree of misalignment. The patented sealing system (Pat. #5,908,249) has proven effective, due to its constant contact pressure, in protecting the internal bearing components under maximum allowable misaligned conditions.

NON-EXPANSION BEARING

1. Clean shaft and bore of bearing. The shaft should be straight, free of burrs and nicks, and correct size (see shaft tolerance table). If used shafting is utilized, then the bearing should be mounted on unworn section of shafting.
2. Lubricate shaft and bearing bore with grease or oil to facilitate assembly. Slip bearing into position. When light press fit is required, press against the end of the inner ring of bearing. Do not strike or exert pressure on the housing or seals.
3. Bolt bearing to support, using shims where necessary to align bearing so inner ring does not rub on seal carrier. Use full shims which extend across the entire housing base.
4. Determine final shaft position and tighten setscrews in the locking collar(s) of non-expansion bearing to recommended torque while the other bearings remain free. Rotate the shaft slowly under load, if possible, to properly center the rolling elements with respect to the raceways. Then tighten setscrews into the locking collar of the remaining bearings to the recommended torque.

WARNING: Because of the possible danger to persons(s) or property from accidents which may result from the improper use of products, it is important that correct procedures be followed: Products must be used in accordance with the engineering information specified in the catalog. Proper installation, maintenance and operation procedures must be observed. The instructions in the instruction manuals must be followed. Inspections should be made as necessary to assure safe operation under prevailing conditions. Proper guards and other suitable safety devices or procedures as may be desirable or as may be specified in safety codes should be provided, and are neither provided by Baldor Electric Company nor are the responsibility of Baldor Electric Company. This unit and its associated equipment must be installed, adjusted and maintained by qualified personnel who are familiar with the construction and operation of all equipment in the system and the potential hazards involved. When risk to persons or property may be involved, a holding device must be an integral part of the driven equipment beyond the speed reducer output shaft.

5. Check rotation. If there is any strain, irregular rotational torque or vibration, it could be due to incorrect alignment, bent shaft or bent supports. Installation should be rechecked and correction made where necessary.

EXPANSION BEARING

1. Clean shaft and bore of bearing. The shaft should be straight, free of burrs and nicks, and correct size (see shaft tolerance table). If used shafting is utilized, then the bearing should be mounted on unworn section of shafting.
2. Lubricate shaft and bearing bore with grease or oil to facilitate assembly. Slip bearing into position. When light press fit is required, press against the end of the inner ring of bearing. Do not strike or exert pressure on the housing or seals.
3. Bolt bearing to support, using shims where necessary to align bearing so inner ring does not rub on seal carrier. Use full shims which extend across the entire housing base.
4. Position expansion bearing in the housing. For normal expansion conditions, the bearing insert should be positioned in the center of the housing. To center bearing insert in housing, move bearing insert to extreme position and mark shaft. Then using bearing maximum total expansion table, move bearing insert in opposite direction one-half the total expansion to center bearing in the housing. If maximum expansion is required, move bearing insert to the extreme position in the housing to permit full movement in direction of expansion. After expansion bearing has been positioned in the housing, tighten the setscrews in the locking collar to the recommended torque.
5. Check rotation. If there is any strain, irregular rotational torque or vibration, it could be due to incorrect alignment, bent shaft or bent supports. Installation should be rechecked and correction made where necessary.

FIELD CONVERSION (RE-OP) OF A NON-EXPANSION BEARING INTO AN EXPANSION BEARING

All non-expansion bearing sizes can be re-oped to become expansion bearings. To re-op a non-expansion to an expansion bearing follow these steps:

1. Move the snap ring, opposite from the collar side of bearing, to the outermost snap ring groove.
2. Install bearing per Expansion Bearing instructions listed above.

NOTE: Bearing nameplate has a non-expansion Part Number. When bearing is re-oped the bearing should be marked as expansion for future reference.

Table 1 - BEARING MAXIMUM TOTAL EXPANSION	
Shaft Size (in.)	Total Expansion (in.)
1-3/8 – 1 1/2	3/16
1-11/16 – 3 7/16	1/14
3-15/16	5/16
4-7/16 – 4 15/16	3/8



LUBRICATION INSTRUCTIONS

OPERATION IN PRESENCE OF DUST, WATER OR CORROSION VAPORS

This bearing is factory lubricated with No. 2 consistency lithium complex base grease which is suitable for most applications. However, extra protection is necessary if bearing is subjected to excessive moisture, dust, or corrosive vapor. In these cases, bearing should contain as much grease as speed will permit (a full bearing with consequent slight leakage through the seal is the best protection against contaminant entry).

In extremely dirty environments, the bearing should be purged daily to flush out contaminants. For added protection, it is advisable to shroud the bearing from falling material.

HIGH SPEED OPERATION

At higher operation speeds, too much grease may cause overheating. In these cases, the amount of lubrication can only be determined by experience. If excess grease causes overheating, remove grease fittings and run for ten minutes. This will allow excess grease to escape. Then wipe off excess grease and replace grease fittings.

In higher speed applications, a small amount of grease at frequent intervals is preferable to a large amount at infrequent intervals. However, the proper volume and interval of lubrication can best be determined by experience.

AVERAGE OPERATIONS

The following table is a general guide for normal operating conditions. However, some situations may require a change in lubricating periods as dictated by experience. If the bearing is exposed to unusual operating conditions, consult a reputable grease manufacturer.

Lubrication Guide

Read Preceding Paragraphs Before Establishing Lubrication Schedule

Hours run per day	1 to 250 rpm	251 to 500 rpm	501 to 750 rpm	751 to 1500 rpm	1001 to 2000 rpm	1501 to 2000 rpm	2001 to 2500 rpm	2501 to 3000 rpm
8	12	12	10	7	5	4	3	2
16	12	7	5	4	2	2	2	1
24	10	5	3	2	1	1	1	1

OPERATING TEMPERATURE

Abnormal bearing temperatures may indicate insufficient lubrication. If the housing is too hot to touch for more than a few seconds, check the temperature by applying a thermometer at the top of the pillow block with the thermometer tip surrounded by putty.

Because the thermometer reading will be approximately 10°F lower than the actual bearing temperature, add ten degrees to the reading and compare to the temperature rating of your grease. If the bearing temperature reading is consistent and operating within the recommended limits of your grease, the bearing is operating satisfactorily. The recommended maximum operating temperature for S-2000 Spherical Roller Bearings is 200 °F.

STORAGE OR SPECIAL SHUT DOWN

If equipment will be idle for some time, before shutting down, add grease to the bearing until grease purges from the seals. This will ensure protection of the bearing, particularly when exposed to severe environmental conditions. After storage or idle period, add fresh grease to the bearing before starting.

Shaft Size	Socket Set Screw Size	Tightening Torque
1-3/8 – 1-3/4 in.	5/16 in.	165 Inch Pounds
1-15/16 – 2-7/16 in.	3/8 in.	290 Inch Pounds
2-11/16 – 3-7/16 in.	1/2 in.	620 Inch Pounds
3-15/16 – 4-15/16 in.	5/8 in.	1325 Inch Pounds

Normal Shaft Size	Low to Normal Equivalent Load and Catalog Speed*	
	+	-
Up to 1-1/2 in.	+0.00 in.	-0.005 in.
Over 1-1/2 to 2-1/2 in.	+0.00 in.	-0.01 in.
Over 2-1/2 to 4 in.	+0.00 in.	-0.01 in.
Over 4 to 5 in.	+0.00 in.	-0.015 in.

*Normal equivalent load .08C to .18C.

On severe applications and where dynamic balance and minimum runout are important, a snug to light press fit may be required to obtain optimum bearing performance. Consult Dodge Product Support.

S-2000 Parts Components

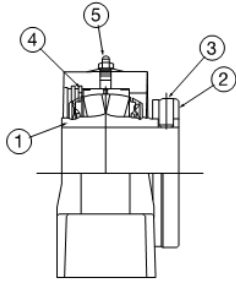

2 BOLT PILLOW
BLOCK S2000-R

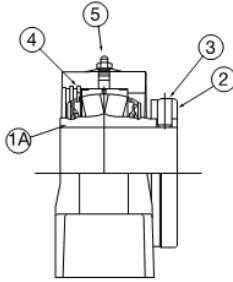

2 BOLT PILLOW
BLOCK S2000-L

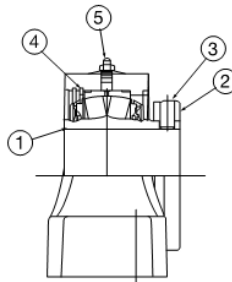

4 BOLT PILLOW
BLOCK S2000-R

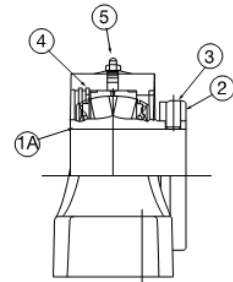

4 BOLT PILLOW
BLOCK S2000-L

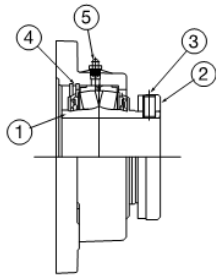

3 & 4 BOLT ROUND
FLANGE S2000-R

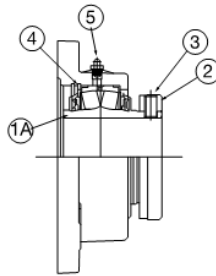

3 & 4 BOLT ROUND
FLANGE S2000-L

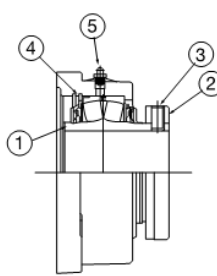

4 BOLT SQUARE
FLANGE S2000-R

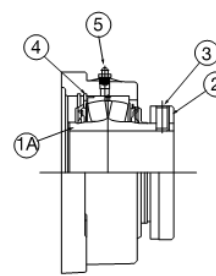

4 BOLT SQUARE
FLANGE S2000-L

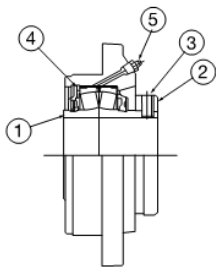

PILOTED FLANGE
S2000-R

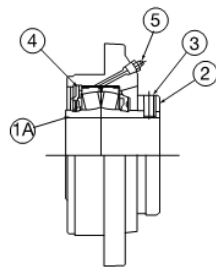

PILOTED FLANGE
S2000-L

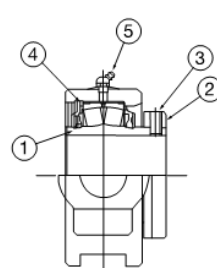

WIDE SLOT TAKE-
UP S2000-R

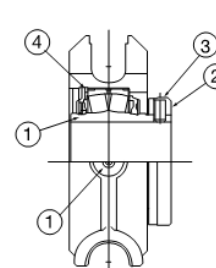

TPHU TAKE-UP
S2000-R

COMPONENT PART NUMBERS (1 3/8" - 4 15/16")						
ITEM	1	1A	2	3	4	5
Shaft Size	Bearing Insert Assembly (R) Seal	Bearing Inert Assembly (L) Seal	*Collar	*Set Screw	Snap Ring	**Grease Fitting
1 3/8	070000	070016	040050	400058	069276	405015
1 7/16	070001	070017	040050	400058	069276	405015
1 1/2	070002	070018	040050	400058	069276	405015
1 11/16	070003	070019	040051	400058	069277	405015
1 3/4	070004	070020	040051	400058	069277	405015
1 15/16	070005	070021	070587	400094	069278	405015
2	070006	070022	070587	400094	069278	405015
2 3/16	070007	070023	070588	400094	069279	405015
2 7/16	070008	070024	040054	400094	069280	405015
2 11/16	070009	070025	070589	400150	069281	405015
2 15/16	070010	070026	070589	400150	069281	405015
3	070011	070027	070589	400150	069281	405015
3 7/16	070012	070028	040056	400154	069282	405015
3 15/16	070013	070029	060946	400186	069283	405015
4 7/16	070014	070030	* 060947	* 400186	069284	405015
4 15/16	070015	070031	* 040059	* 400190	069285	405015
QTY/PER	1	1	1	2	1	1
*Shaft sizes 4 7/16" - 4 15/16" have two collars a ** WSTU and TPHU TU take a 405016 grease fitting.						



P.O. Box 2400, Fort Smith, AR 72902-2400 U.S.A., Ph: (1) 479.646.4711, Fax (1) 479.648.5792, International Fax (1) 479.648.5895

Dodge Product Support

6040 Ponders Court, Greenville, SC 29615-4617 U.S.A., Ph: (1) 864.297.4800, Fax: (1) 864.281.2433

www.baldor.com

© Baldor Electric Company
MN3033 (Replaces 499330)



All Rights Reserved. Printed in USA.
3/12 Printshop 200

Dodge Imperial and ISAF Bearings

Instruction Manual for Dodge Imperial & ISAF Bearing

These instructions must be read thoroughly before installation or operation.

WARNING: To ensure the drive is not unexpectedly started, turn off and lock-out or tag power source before proceeding. Failure to observe these precautions could result in bodily injury.

Inspection

Inspect shaft to ensure it is smooth, straight, clean, and within commercial tolerances.

Mounting

Install the Non-Expansion unit first.

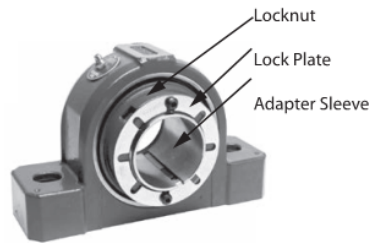

Figure 1

1. Remove lock plate located on the face of the locknut.
2. Turn locknut counter clockwise until bearing will freely slide onto the shaft.
3. Slide bearing to the desired position on the shaft.

NOTE: All Weight Must Be Removed from the Bearing When Obtaining The ZERO Reference Point".

4. The "ZERO Reference Point" is defined as the point when the clearance between the adapter sleeve, shaft and bearing bore has been removed.

To reach the "ZERO Reference Point" rotate locknut clockwise, using both hands, as tight as possible. When

WARNING: Because of the possible danger to persons(s) or property from accidents which may result from the improper use of products, it is important that correct procedures be followed. Products must be used in accordance with the engineering information specified in the catalog. Proper installation, maintenance and operation procedures must be observed. The instructions in the instruction manuals must be followed. Inspections should be made as necessary to assure safe operation under prevailing conditions. Proper guards and other suitable safety devices or procedures as may be desirable or as may be specified in safety codes should be provided, and are neither provided by Baldor Electric Company nor are the responsibility of Baldor Electric Company. This unit and its associated equipment must be installed, adjusted and maintained by qualified personnel who are familiar with the construction and operation of all equipment in the system and the potential hazards involved. When risk to persons or property may be involved, a holding device must be an integral part of the driven equipment beyond the speed reducer output shaft.

mounting bearing with shaft sizes 3-15/16" and larger, the following TEST must be performed. As a test to insure you have reached the "ZERO Reference Point" tap on the O. D. of the nut with a hammer and attempt to rotate the nut using both hands. If the nut will not rotate then you have reached the "ZERO Reference Point" and you should proceed to step 5. If you can rotate the nut, using both hands, then you have not reached the true "ZERO Reference Point", and should repeat step 4A until "ZERO Reference Point" is obtained. When the "ZERO Reference Point" is reached, the bearing will not be able to move by hand axially on the shaft.

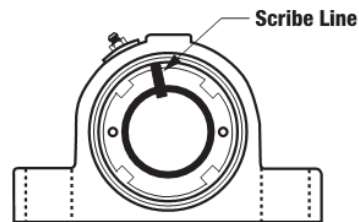

Figure 2

5. Scribe a line through the locknut face and adapter race.
6. Using a Spanner or Drift & Hammer, rotate locknut clockwise by the number of turns shown in Table 1.

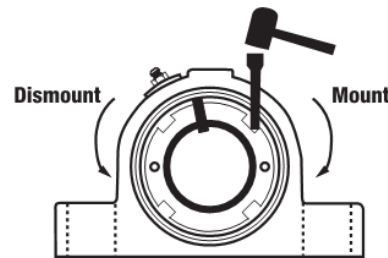

Figure 3

Table 1 - Locknut Rotation from "Zero Reference Point"

Shaft Size (inches)	Locknut Rotation
1-1/8 - 1 7/16	3/4 to 7/8 turn
* 1-1/2	3/4 to 7/8 turn
** 1-1/2	7/8 to 1 turn
1-5/8 - 2	7/8 to 1 turn
2-3/16 - 3	1 to 1-1/4 turns
3-3/16 - 4	1-1/4 to 1-1/2 turns
4-7/16 - 4 1/2	1-1/8 to 1-3/8 turns
4-15/16 - 5 1/2	1-3/8 to 1-5/8 turns
5-15/16 - 6	1 to 1-1/4 turns
6-7/16 - 7	1-1/8 to 1-3/8 turns

* IMPERIAL IP & ISAF

** IMPERIAL IP With Type E Dimensioned Housing

BALDOR • DODGE

7. Slide lock plate over shaft and align tang of lock plate with slot in adapter sleeve.
8. **TIGHTEN NOT LOOSEN** locknut until lock plate slots overlap the two threaded holes on the locknut face.
9. Insert and tighten button head screws to locknut face.
10. Bolt down pillow block or flange unit to the structure.

Install the Expansion Unit

1. Remove lock plate located on the face of the locknut.
2. Turn locknut counter clockwise until bearing will freely slide onto the shaft.
 - a. If Locknut Facing Outboard: Align housing mounting holes with substructure mounting holes and snug bolts. Push insert as far as possible in the direction of the fixed bearing.
 - b. If Locknut Facing Non-Expansion Bearing: Align housing mounting holes with substructure mounting holes and snug bolts. Position Expansion bearing insert in center of housing (NOTE: This is necessary because in the process of mounting, the bearing is being drawn toward the locknut.)

Note: All Weight Must be Removed from the Bearing when Obtaining the "ZERO Reference Point".

3. Follow steps 4 through 10 found under mounting of the Non-Expansion bearing.

Dismounting

1. Remove weight off bearing via slings or jacks.
2. Remove mounting bolts from bearing.
3. Remove button head screws and lock plate from locknut.
4. (Figure 3) Rotate locknut counter clockwise until bearing freely slides from the shaft.

Field Conversion of a Non-Expansion Bearing into an Expansion Bearing

Imperial IP

1. Move snap ring opposite collar side, to the outmost snap ring groove.
2. Remove Non-Expansion nameplate and re-label as an Expansion bearing.

ISAF

1. Remove bearing cap.
2. Remove stabilizing ring.
3. Reassemble cap on base and torque cap bolts to values in Table 2.

Table 2 - Cap Bolt Torque for ISAF Grade 5 Bolts

ISAF Shaft Size (inches)	2 Bolt Base		4 Bolt Base	
	Bolt Size	Torque Ft-Lbs.	Bolt Size	Torque Ft-Lbs.
1-7/16 - 1-11/16	3/8 - 16	24 - 30		
1-15/16 - 2-3/16	7/16 - 14	40 - 50		
2-7/16 - 2-1/2	1/2 - 13	60 - 75	1/2 - 13	60 - 75
2-11/16 - 3	5/8 - 11	120 - 150	5/8 - 11	120 - 150
3-3/16 - 3-1/2	3/4 - 10	208 - 260	3/4 - 10	208 - 260
3-11/16 - 4			3/4 - 10	208 - 260
4-7/16 - 4-1/2			7/8 - 9	344 - 430
4-15/16 - 7			1 - 8	512 - 640

Grease Lubrication

DODGE IP and ISAF bearings are pre-packed with NLGI #2 Lithium Complex grease. For re-lubrication select a grease that is compatible with a #2 Lithium Complex grease. Re-lubricate in accordance with Table 3.

Storage or Special Shutdown

If exposed to wet or dusty conditions or to corrosive vapors, extra protection is necessary. Add grease until it shows at the seals; rotate the bearing to distribute grease; cover the bearing. After storage or idle period, add a little fresh grease before running.

Table 3 - Re-Lubrication Intervals (Months) Based on 12 hours per day, 150° F M

Shaft Size (inches)	RPM								
	250	500	750	1000	1250	1500	2000	2500	>3000
1-1/8 to 2	4	3	2	2	1	0.5	0.25	0.25	0.25
2-3/16 to 2-1/4	3.5	2.5	1.5	1	0.5	0.5	0.25	0.25	0.25
2-3/8 to 3	3	2	1.5	1	0.5	0.25	0.25	0.25	0.25
3-3/16 to 3-1/2	2.5	1.5	1	0.5	0.25	0.25	0.25	0.25	-
3-11/16 to 4-1/2	2	1.5	1	0.5	0.25	0.25	0.25	-	-
4-15/16 to 5-1/2	1.5	1	0.5	0.25	0.25	0.25	-	-	-
5-15/16 to 6	1	0.5	0.5	0.25	0.25	0.25	-	-	-
6-7/16 to 7	1	0.5	0.25	0.25	0.25	-	-	-	-



P.O. Box 2400, Fort Smith, AR 72902-2400 U.S.A., Ph: (1) 479.646.4711, Fax (1) 479.648.5792, International Fax (1) 479.648.5895

Dodge Product Support

6040 Ponders Court, Greenville, SC 29615-4617 U.S.A., Ph: (1) 864.297.4800, Fax: (1) 864.281.2433

www.baldor.com

© Baldor Electric Company
MN3009 (Replaces 499331)



All Rights Reserved. Printed in USA.
05/14 Litho 25,000

Dodge QD Bushings

QD* Bushings

These instructions must be read thoroughly before installation or operation.

WARNING: To ensure that drive is not unexpectedly started, turn off and lock out or tag power source before proceeding. Failure to observe these precautions could result in bodily injury.

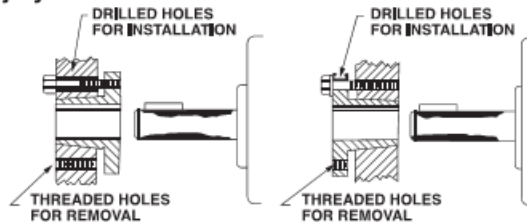

Figure 1 - Conventional Mounting

Figure 2 - Reverse Mounting

INSTALLATION:

1. Clean shaft, product bore, bushing, tapered surface and bushing bore of oil, paint dirt, etc.

CAUTION: DO NOT USE LUBRICANTS. The use of lubricants can cause product breakage during installation.

2. QD bushing sizes JA thru W (see table on page 2) may be assembled in either conventional or reverse mounting. Size H must be assembled in conventional mounting position only.

CAUTION: When mounting a product on size M thru S bushings, the hub jack holes should be positioned away from the bushing saw slot to reduce the possibility of bushing breakage and insert cap screws through drilled holes in hub.

Conventional Mounting (Fig. 1): Place bushing in hub. Tighten cap screws finger tight into threaded holes in bushing flange.

Reverse Mounting (Fig. 2): Place bushing in hub and insert cap screws thru drilled holes in bushing flange. Tighten cap screws finger tight into threaded holes in hub.

3. With key on shaft, slide loosely assembled unit onto shaft so that cap screw heads are on the outside. Locate unit in desired position on shaft. When using conventional mounting for large or heavy parts, it may be easier to mount the key and bushing on the shaft first, then place the product on the bushing aligning the holes and installing the cap screws.

WARNING: When mounting on a vertical shaft, insure that the products and/or bushing do not drop during installation.

4. Tighten cap screws alternately and evenly to the wrench torque specified in table below.

Note: When tightened there will be a 1/8" to 1/4" gap between bushing flange and hub. Should this gap close, then either undersize shafting or wrong bushing shaft size is indicated.

CAUTION: Excessive screw torque may cause damage to either bushing and/or product.

5. Tighten setscrew over key to torque value listed below.

Warning: Because of the possible danger to person(s) or property from accidents, which may result from the improper use of products. It is important that correct procedures be followed. Products must be used in accordance with the engineering information specified in the catalog. Proper installation, maintenance and operation procedures must be observed. The instructions in the instruction manual must be followed. Inspections should be made as necessary to assure safe operation under prevailing conditions. Proper guard and other suitable safety devices or procedures as may be desirable or as may be specified in safety codes should be provided and are neither provided by Baldor Electric Company nor are the responsibility of Baldor Electric Company or the manufacturer of this component. This unit and its associated equipment must be installed, adjusted and maintained by qualified personnel who are familiar with the construction and operation of all equipment in the system and the potential hazards involved. When risk to persons or property may be involved, a holding device must be an integral part of the driven equipment beyond the speed reducer output shaft.



REMOVAL

1. Remove all cap screws.
2. Install cap screws into threaded jack holes.
3. Tighten all jackscrews alternately and evenly, beginning with screw farthest from bushing saw slot, until bushing grip is released. Slide unit off shaft.

CAUTION: Excessive screw torque may cause damage to either bushing and/or product. Uneven pressure on jackscrews may also damage the bushing flange making removal difficult without damage to the product.

Recommended Torque - English					Recommended Torque - Metric				
Bushings	Cap Screws		Key Seat Set Screws		Bushings	Cap Screws		Key Seat Set Screws	
	Size	lb-in	Size	lb-in		Size	N-m	Size	N-m
QT	1/4-20 x 7/8	90	#10-24	36	QT	M6 x 1 x 25	5.6	-	-
JA	#10-24 x 1	60	#10-24	36	JA	M5 x 0.8 x 22	9.6	-	-
SH	1/4-20 x 1-3/8	108	1/4-20	87	SH	M6 x 1 x 35	11.5	M6 x 1	7.7
SDS	1/4-20 x 1-3/8	108	1/4-20	87	SDS	M6 x 1 x 35	11.5	M6 x 1	7.7
SD	1/4-20 x 1-7/8	108	1/4-20	87	SD	M6 x 1 x 50	11.5	M6 x 1	7.7
SK	5/16-18 x 2	180	1/4-20	87	SK	M8 x 1.25 x 50	20.5	M6 x 1	7.7
SF	3/8-16 x 2	360	5/16-18	165	SF	M10 x 1.5 x 50	34	M10 x 1.5	35
E	1/2-13 x 2-3/4	720	3/8-16	290	E	M12 x 1.75 x 70	77	M10 x 1.5	35
F	9/16-12 x 3-5/8	900	3/8-16	290	F	M14 x 2 x 100	100	M10 x 1.5	35
J	5/8-11 x 4-1/2	1620	3/8-16	290	J	M16 x 2 x 120	194.5	M12 x 1.75	55
M	3/4-10 x 7	2700	3/8-16	290	M	M20 x 2.5 x 180	256	M12 x 1.75	55
N	7/8-9 x 8	3600	1/2-13	620	N	-	-	-	-
P	1-8 x 9-1/2	5400	5/8-11	1325	P	-	-	-	-
W	1-1/8-7 x 11-1/2	7200	1-8	5000	W	-	-	-	-
S	1-1/4-7 x 15-1/2	9000	1-1/4-7	7600	S	-	-	-	-

Bag of Hardware (Includes 3 cap screws and 3 washers)			
Bushings	Part Numbers - English	Bushings	Part Numbers - Metric
QT	411682	QT	411801
JA	411683	JA	411802
SH	411684	SH	411803
SDS	411684	SDS	411803
SD	411685	SD	411805
SK	411686	SK	411806
SF	411687	SF	411807
E	411688	E	411808
F	411689	F	411809
J	411690	J	411810
M	411691	M	411811
N	411692	N	411812
P	411693	P	411813

*QD is a registered trademark of EMERSON



BALDOR

World Headquarters
 P.O. Box 2400, Fort Smith, AR 72902-2400 U.S.A., Ph: (1) 479.646.4711, Fax (1) 479.648.5792, International Fax (1) 479.648.5895
 Dodge Product Support
 6040 Ponders Court, Greenville, SC 29615-4617 U.S.A., Ph: (1) 864.297.4800, Fax: (1) 864.281.2433

© Baldor Electric Company
 MN4049 (Replaces 499738)

www.baldor.com

All Rights Reserved. Printed in USA.
 3/10 TCP 30,000

Dodge XT Pulley Bushing

Conveyor Pulley Bushing Instruction Manual

These instructions must be read thoroughly before installing or operating this product. This instruction manual was accurate at the time of printing. Please see www.dodge-pt.com for updated instruction manuals.

WARNING: To ensure the drive is not unexpectedly started, turn off and lock-out or tag power source before proceeding. Failure to observe these precautions could result in bodily injury.

PURPOSE

This procedure provides general direction and guidelines for the installation, operation, and storage of conveyor pulley bushings.

TAPER-LOCK

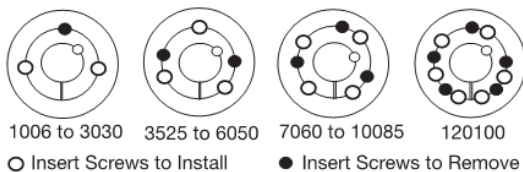

INSTALLATION

1. Determine bushing size from identification on face of bushing.
2. Clean shaft, bore and outside of bushings, and bore of hubs (taking bushings from hubs if already assembled). Remove any oil, grease and dirt.
3. Slip shaft into pulley hubs and slip bushings onto shaft and into hubs. Place screws loosely in holes that are threaded on hub side (shown as O on diagram above).
4. Locate shaft in desired position and tighten screws in each bushing slightly to seat bushings in hubs.
5. Tighten screws alternately and evenly in one bushing only until all screws are pulled up to the proper wrench torque listed in Table 1. Do NOT over torque. Hammer against large end of bushing. Hammer first beside the screw farthest from the bushing split and then hammer on the bushing on the opposite side of the screw. Avoid hammering close to the O.D. of the bushing to prevent damage. Working toward the split, hammer on the bushing on each side of each screw. Then hammer on each side of the bushing split. Make sure that the surfaces on both sides of the split are even. Screws can now be tightened a little more using the specified torque. Repeat this alternating hammering and retightening until the specified wrench torque no longer turns the screws after hammering. Check to make

WARNING: Because of the possible danger to person(s) or property from accidents which may result from the improper use of products, it is important that correct procedures be followed. Products must be used in accordance with the engineering information specified in the catalog. Proper installation, maintenance and operation procedures must be observed. The instructions in the instruction manuals must be followed. Inspections should be made as necessary to assure safe operation under prevailing conditions. Proper guards and other suitable safety devices or procedures as may be desirable or as may be specified in safety codes should be provided, and are neither provided by Baldor Electric Company nor are the responsibility of Baldor Electric Company. This unit and its associated equipment must be installed, adjusted and maintained by qualified personnel who are familiar with the construction and operation of all equipment in the system and the potential hazards involved. When risk to persons or property may be involved, a holding device must be an integral part of the driven equipment beyond the speed reducer output shaft.

sure the surfaces on both sides of the split are even. Fill all other holes with grease to exclude dirt. If a key seated bushing is used without a key, a fluid resistant material to prevent moisture can be filled in the key seat.

6. Tighten the second bushing per step 5.

REMOVAL

1. Remove all screws.
2. Insert screws into holes that are threaded on the bushing side (shown as ● on diagram). In sizes where washers are found under the screw heads, be sure to use the washers.

NOTE: One screw in each hub is left over and is not used in the removal process.

3. Tighten screws alternately until bushings are loosened in hubs. If bushing does not loosen, tap on face of hub.

HE, QD®, AND XT®

INSTALLATION

1. Determine bushing size from identification on face of bushing.
2. Clean shaft, bore and outside of bearings, and bore of hubs (taking bushings from hubs if already assembled). Remove any oil, grease and dirt.
3. Slip shaft into pulley and slip bushings onto shaft and into hubs. If required, carefully insert a wedge into bushing split and tap lightly to allow bushing to slide on shaft. Align unthreaded holes in bushing with threaded holes in hub. Place bolts loosely in holes that are not threaded.
4. Locate shaft in desired position, remove wedges if used and tighten bolts in each bushing slightly to seat bushings in hubs.
5. Tighten bolts in a star pattern alternately and evenly as illustrated in Figures 1 - 6 in one bushing only until all bolts are pulled up to the proper wrench torque listed in Table 1. Do NOT over torque. If a key seated bushing is used without a key, a fluid resistant material to prevent moisture can be filled in the key seat.
6. Check to ensure the bushing flange does not contact the hub.
7. Tighten the second bushing per step 5.

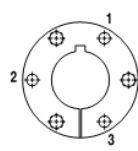

Figure 1: QD-SF thru J

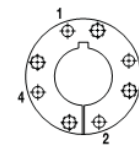

Figure 2: QD-M thru W

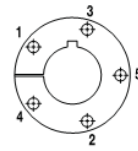

Figure 3: QD-S thru Z

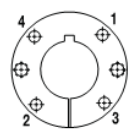

Figure 4: HE-25 thru 40, XT-15 through 80

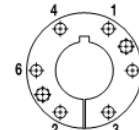

Figure 5: HE-45 through 100, XT-100

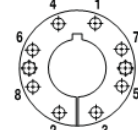

Figure 6: HE-120, XT-120

BALDOR • DODGE®

REMOVAL

1. Remove all bolts.
2. Insert bolts into threaded holes on bushing flange.
3. Tighten bolts alternately until bushings are loosened in hubs. If bushing does not loosen, carefully insert a wedge into bushing split and tap lightly to allow bushing to slide on shaft.

*QD is a registered trademark of Emerson Electric Co.
 *XT is a registered trademark of Van Gorp Corporation

LONG-TERM PULLEY STORAGE INSTRUCTIONS

1. Block the pulley to keep the face from touching the ground.
2. Inside storage is recommended. If stored outside, protect the pulley from harsh elements.
3. Clean the assembly before installation.

SHAFTING

1. A protective coating has been applied at the factory to all exposed surfaces. For long term storage, additional coatings of rust preventative are recommended.
2. Remove protective coatings before assembly of bearings or other components.

LAGGED PULLEYS

1. Inside storage is recommended. Store in a cool, dark area where the pulley will not be exposed to direct sunlight or extreme temperature or humidity variations. Areas of high ozone concentration, such as areas with electric motors or other electrical arc producing machinery, should not be used for storage.
2. Do NOT allow oil, grease, kerosene, solvents, or other chemicals to contact the lagging.
3. After long-term storage, some oxidation may occur on lagging surface. Reduce lagging thickness by 1/32" by grinding to remove the oxidation.

PILLOW BLOCKS

1. Refer to manufacturer's recommendations.

GENERAL OPERATION INSTRUCTIONS

1. For best practice, bushing bolts should be re-torqued weekly for the first month of operation.
2. No modifications, repair, or other work should be performed on the conveyor pulley assembly without prior written consent of Baldor Electric Company.
3. Do NOT allow material to be trapped between the belt and pulley face.
4. Do NOT allow material to build up on the pulley face.
5. Do NOT allow the edge of the conveyor belt to wander past the edge of the rim.
6. Do NOT skew the pulley in an attempt to track the conveyor belt.

Table 1 - Recommended Tightening Torque

Bushings Type	Screws		Torque lb-ft	Hammer Size (TL Only)	
	Qty	Size			
TL	1210,1215,1310,1610 & 1615	2	3/8-16 NC	15	6 LB.
	2012	2	7/16-14 NC	23	6 LB.
	2517 & 2525	2	1/2-13 NC	36	6 LB.
	3020 & 3030	2	5/8-11 NC	67	6 LB.
	3535	3	1/2-13 NC	83	12 LB.
	4040	3	5/8-11 NC	142	12 LB.
	4545	3	3/4-10 NC	204	12 LB.
	5050	3	7/8-9 NC	258	12 LB.
	6060	3	1-1/4-7 NC	650	20 LB.
	7060 & 8065	4	1-1/4-7 NC	650	20 LB.
	10085	4	1-1/2-6 NC	1140	20 LB.
	120100	6	1-1/2-6 NC	1140	20 LB.
HE	HE25	4	3/8-16 NC	30	N/A
	HE30	4	1/2-13 NC	60	
	HE35	4	9/16-12 NC	90	
	HE40	4	5/8-11 NC	140	
	HE45	6	5/8-11 NC	140	
	HE50	6	3/4-10 NC	200	
	HE60	6	7/8-9 NC	350	
	HE70	6	1-8 NC	500	
	HE80	6	1-1/8-7 NC	500	
HE100	6	1-1/4-7 NC	600		
HE120	8	1-1/4-7 NC	600		
QD	SF	3	3/8-16 NC	30	N/A
	E	3	1/2-13 NC	60	
	F	3	9/16-12 NC	75	
	JS or J	3	5/8-11 NC	135	
	MS or M	4	3/4-10 NC	225	
	NS or N	4	7/8-9 NC	300	
	PS or P	4	1-8 NC	450	
	WS or W	4	1-1/8-7 NC	600	
	SS or S	5	1-1/4-7 NC	750	
ZS or Z	5	1-1/8-7 NC	600		
XT	XTB15	4	1/4-20 NC	7.9	N/A
	XTB20	4	5/16-18 NC	16.7	
	XTB25	4	3/8-16 NC	29.2	
	XTB30	4	7/16-14 NC	45.8	
	XTB35	4	1/2-13 NC	70	
	XTB40	4	9/16-12 NC	100	
	XTB45	4	5/8-11 NC	140	
	XTB50	4	3/4-10 NC	250	
	XTB60	4	7/8-9 NC	400	
	XTB70	4	1-8 NC	600	
	XTB80	4	1-1/8-7 NC	750	
	XTB100	6	1-1/8-7 NC	750	
XTB120	8	1-1/8-7 NC	750		

* Torque values listed are based on dry torque.

Dodge product installation manuals

These can be found on the Dodge website using the following address: http://www.baldor.com/support/product_manuals.asp



P.O. Box 2400, Fort Smith, AR 72902-2400 U.S.A., Ph: (1) 479.646.4711, Fax (1) 479.648.5792, International Fax (1) 479.648.5895

Dodge Product Support

6040 Ponders Court, Greenville, SC 29615-4617 U.S.A., Ph: (1) 864.297.4800, Fax: (1) 864.281.2433

www.baldor.com

© Baldor Electric Company
 MN4005 (Replaces 499657)



All Rights Reserved. Printed in USA.
 12/14 Litho 10,000

Dodge Torque Arm II Reducers

Instruction Manual
DODGE® TORQUE-ARM™ II Speed Reducers
Ratios 5, 9, 15, 25, and 40:1

- | | |
|----------------|-----------------|
| TA0107L | TA6307H |
| TA1107H | TA7315H |
| TA2115H | TA8407H |
| TA3203H | TA9415H |
| TA4207H | TA10507H |
| TA5215H | TA12608H |

These instructions must be read thoroughly before installation or operation.

WARNING: To ensure that drive is not unexpectedly started, turn off and lock out or tag power source before proceeding. Remove all external loads from drive before removing or servicing drive or accessories. Failure to observe these precautions could result in bodily injury.

INSTALLATION

1. Use lifting bracket to lift reducer.
2. Determine the running positions of the reducer (Figure 1). Note that the reducer is supplied with 6 plugs; 4 around the sides for horizontal installations and 1 on each face for vertical installations. These plugs must be arranged relative to the running positions as follows:

Horizontal Installations -Install the magnetic drain plug in the hole closest to the bottom of the reducer. Throw away the tape that covers the filter/ventilation plug in shipment and install plug in topmost hole. Of the 2 remaining plugs on the sides of the reducer, the lowest one is the minimum oil level plug.

Vertical Installations -Install the filter/ventilation plug in the hole provided in the upper face of the reducer housing as installed. If space is restricted on the upper face, install the vent in the highest hole on the side of the reducer per Figure 1. Install a plug in the hole in the bottom face of the reducer. Do not use this hole for the magnetic drain plug. Of the remaining holes on the sides of the reducer, use the plug in the upper housing half for the minimum oil level plug.

WARNING: Because of the possible danger to person(s) or property from accidents which may result from the improper use of products, it is important that correct procedures be followed. Products must be used in accordance with the engineering information specified in the catalog. Proper installation, maintenance and operation procedures must be observed. The instructions in the instruction manuals must be followed. Inspections should be made as necessary to assure safe operation under prevailing conditions. Proper guards and other suitable safety devices or procedures, as may be desirable, or as may be specified in safety codes should be provided, and are neither provided by Baldor Electric Company, nor are the responsibility of Baldor Electric Company. This unit and its associated equipment must be installed, adjusted and maintained by qualified personnel who are familiar with the construction and operation of all equipment in the system and the potential hazards involved. When risks to persons or property may be involved, a holding device must be an integral part of the driven equipment beyond the speed reducer output shaft.

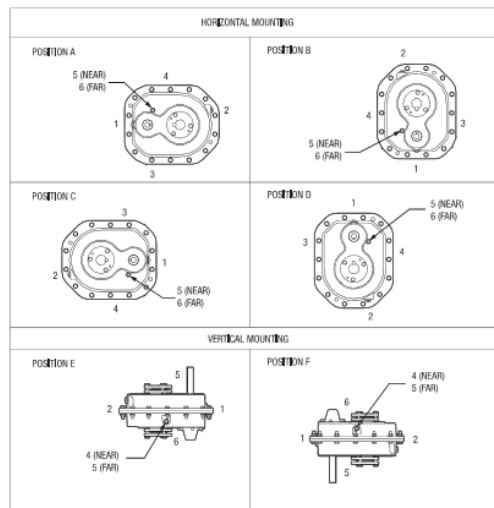

Output Speeds Above 15 RPM						
Mounting Position	Vent and Plug Locations					
	1	2	3	4	5	6
Position A	Level	Plug	Drain	Vent	Plug	Plug
Position B	Drain	Vent	Level	Plug	Plug	Plug
Position C	Plug	Level	Vent	Drain	Plug	Plug
Position D	Vent	Drain	Level	Plug	Plug	Plug
Position E	Level	Plug	Plug	Drain	Vent	Plug
Position F	Plug	Drain	Level	Plug	Plug	Vent

Output Speeds Above 15 RPM and Below *						
Mounting Position	Vent and Plug Locations					
	1	2	3	4	5	6
Position A	Plug	Level	Drain	Vent	Plug	Plug
Position B	Drain	Vent	Plug	Level	Plug	Plug
Position C	Level	Plug	Vent	Drain	Plug	Plug
Position D	Vent	Drain	Level	Plug	Plug	Plug
Position E	Level	Plug	Plug	Drain	Vent	Plug
Position F	Plug	Drain	Level	Plug	Plug	Vent

* Below 15 RPM output speed, oil level must be adjusted to reach the highest oil level plug. If reducer position is to vary from those shown in Figure 1, either more or less oil may be required. Consult Baldor Electric Company Dodge Engineering in Greenville, SC.

Figure 1 - Mounting Positions



The running position of the reducer in a horizontal application is not limited to the four positions shown in Fig. 1. However, if running position is over 20° in position "B" & "D" or 5° in position "A" & "C", either way from sketches, the oil level plug cannot be used safely to check the oil level, unless during the checking, the torque arm is disconnected and the reducer is swung to within 5° for position "A" & "C" or 20° for position "B" & "D" of the positions shown in Figure 1. Because of the many possible positions of the reducer, it may be necessary or desirable to make special adaptations using the lubrication filling holes furnished along with other standard pipe fittings, stand pipes and oil level gauges as required.

If mounting the Torque-Arm II reducer on an inclined angle, consult Dodge for proper oil level.

3. Mount reducer on driven shaft as follows:
For Taper Bushed Reducer: Mount reducer on driven shaft per instruction in Torque-Arm II Bushing Installation section of this manual.
4. Install sheave on input shaft as close to reducer as practical (Figure 2).
5. If not using a Dodge Torque-Arm II motor mount, install motor and V-belt drive so belt will approximately be at right angles to the centerline between driven and input shaft (Figure 3). This will permit tightening the V-belt with the torque arm.
6. Install torque arm and adapter plates reusing the reducer bolts. The adapter plates will fit in any position around the input end reducer.
7. Install torque arm fulcrum on a flat and rigid support so that the torque arm will be approximately at right angles to the centerline through the driven shaft and the torque arm anchor screw (Figure 4). Make sure that there is sufficient take-up in the turnbuckle for belt tension adjustment when using V-belt drive.

CAUTION: Unit is shipped without oil. Add proper amount of recommended lubricant before operating. Failure to observe this precaution could result in damage to or destruction of the equipment.

8. Fill gear reducer with recommended lubricant (Table 2).

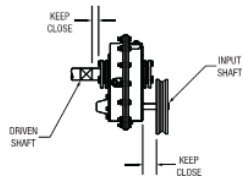

Figure 2 - Reducer and Sheave Installation

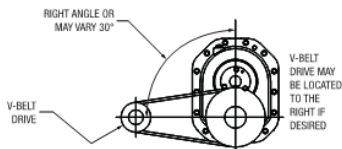

Figure 3 - Angle of V-Drive

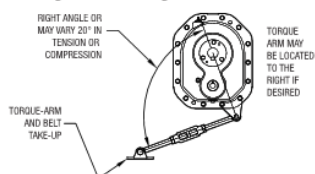

Figure 4 - Angle of Torque-Arm

TORQUE-ARM II BUSHING INSTALLATION

WARNING: To ensure that drive is not unexpectedly started, turn off and lock out or tag power source before proceeding. Remove all external loads from drive before removing or servicing drive or accessories. Failure to observe these precautions could result in bodily injury.

The Dodge Torque-Arm II reducer is designed to fit both standard and short length driven shafts. The Standard Taper Bushings series is designed where shaft length is not a concern. The Short Shaft Bushing series is to be used where the driven shaft does not extend through the reducer.

Standard Taper Bushings:

1. One bushing assembly is required to mount the reducer on the driven shaft. An assembly consists of two tapered bushings, bushing screws and washers, two bushing backup plates and retaining rings, and necessary shaft key or keys. The driven shaft must extend through the full length of the reducer. If the driven shaft does not extend through the reducer do not use the standard tapered bushings; instead use the short shaft bushings as described in the Short Shaft Bushings section that follows. The minimum shaft length, as measured from the end of the shaft to the outer edge of the bushing flange (Figure 5), is given in Table 1.
2. Install one bushing backup plate on the end of the hub and secure with the supplied retaining ring. Repeat procedure for other side.
3. Place one bushing, flange end first, onto the driven shaft and position per dimension "A", as shown in Table 1. This will allow the bolts to be threaded into the bushing for future bushing and reducer removal.
4. Insert the output key in the shaft and bushing. For easy of installation, rotate the driven shaft so that the shaft keyseat is at the top position.
5. Mount the reducer on the driven shaft and align the shaft key with the reducer hub keyway. Maintain the recommended minimum distance "A" from the shaft bearing.
6. Insert the screws, with washers installed, in the unthreaded holes in the bushing flange and align with the threaded holes in the bushing backup plate. If necessary, rotate the bushing backup plate to align with the bushing screws. Tighten the screws lightly. If the reducer must be positioned closer than dimension "A", place the screws with washers installed, in the unthreaded holes in the bushing before positioning reducer making sure to maintain at least 1/8" between the screw heads and the bearing.
7. Place the second tapered bushing in position on the shaft and align the bushing keyway with the shaft key. Align the unthreaded holes in the bushing with the threaded holes in the bushing backup plate. If necessary, rotate the bushing backup plate to align with the bushing holes. Insert bushing screws, with washers installed in the unthreaded holes in the bushing. Tighten screws lightly.
8. Alternately and evenly tighten the screws in the bushing nearest the equipment to the recommended torque given in Table 1. Repeat procedure on outer bushing.

Short Shaft Bushings:

1. One bushing assembly is required to mount the reducer on the driven shaft. An assembly consists of one long tapered bushing, one short tapered bushing, one tapered bushing wedge, bushing screws and washers, two bushing backup plates and retaining rings, and necessary shaft key or keys. The driven shaft does not need to extend through the reducer for the short shaft bushing to operate properly. The minimum shaft length, as measured from the end of the shaft to the outer edge of the bushing flange (Figure 5), is given in Table 1.

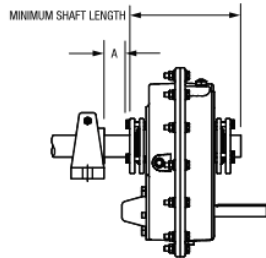

Figure 5 – Minimum Recommended Dimensions

Table 1 – Minimum Mounting Dimensions and Bolt Torques

Reducer Size	Minimum Required Shaft Length	
	Standard Taper Bushing	Short Shaft Bushing
TA0107L	6.83	4.32
TA0107L	6.83	4.32
TA1107H	6.95	4.43
TA2115H	7.80	4.80
TA3203H	8.55	5.46
TA4207H	8.94	5.66
TA5215H	10.33	6.35
TA6307H	10.82	6.72
TA7315H	11.87	7.62
TA8407H	12.82	8.10
TA9415H	13.74	8.56
TA10507H	15.46	9.67
TA12608H	18.32	11.60

Bushing Screw Information and Minimum Clearance for Removal			
Reducer Size	Fastener Size	Torque in lb-ft	A
TA0107L	5/16-18	20-17	1.08
TA1107H	5/16-18	20-17	1.20
TA2115H	3/8-16	20-17	1.20
TA3203H	3/8-16	20-17	1.20
TA4207H	3/8-16	26-23	1.48
TA5215H	1/2-13	77-67	1.81
TA6307H	1/2-13	77-67	1.81
TA7315H	1/2-13	77-67	2.06
TA8407H	1/2-13	77-67	2.06
TA9415H	5/8-11	86-75	2.39
TA10507H	5/8-11	86-75	2.39
TA12608H	5/8-11	86-75	2.39

- The long bushing is designed to be installed from the side of the reducer opposite the driven equipment as shown in Figure 6. The long bushing when properly installed is designed to capture the end of the customer shaft that does not extend through the reducer. Normally the reducer would be mounted such that the input shaft extends from the side of the reducer opposite the driven equipment however the reducer design allows installation of the reducer to be mounted in the opposite direction.
- Install the tapered bushing wedge into the hollow bore of the reducer from the same side as the long bushing will be installed. When installing the tapered bushing wedge into the reducer hub, install the flange end first so that the thin taper is pointing outwards towards the long bushing as shown in Figure 6. The wedge is properly installed when it snaps into place in the reducer hub.

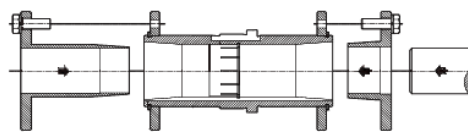

Figure 6 – Short Shaft Bushing and Output Hub Assembly

- Align the tapered bushing wedge keyway with the reducer hub keyway. The keyway in the wedge is slightly wider than the keyway in the reducer hub allowing for easier installation.
- Install one bushing backup plate on the end of the hub and secure with the supplied retaining ring. Repeat procedure for other side.
- Install the short bushing; flange first, on the driven shaft and position per dimension "A", as shown in Table 1. This will allow the bolts to be threaded into the bushing for future bushing and reducer removal.
- Insert the output key in the shaft and bushing. For easy of installation, rotate the driven shaft so that the shaft keyseat is at the top position.
- Mount the reducer on the driven shaft and align the shaft key with the reducer hub keyway. Maintain the recommended minimum distance "A" from the shaft bearing.
- Insert the screws, with washers installed, in the unthreaded holes in the bushing flange and align with the threaded holes in the bushing backup plate. If necessary, rotate the bushing backup plate to align with the bushing screws. Tighten the screws lightly. If the reducer must be positioned closer than dimension "A", place the screws with washers installed, in the unthreaded holes in the bushing before positioning reducer making sure to maintain at least 1/8" between the screw heads and the bearing.
- Place the long bushing in position on the shaft and align the bushing keyway with the shaft key. Use care to locate the long bushing with the tapered bushing wedge installed earlier. Align the unthreaded holes in the bushing with the threaded holes in the bushing backup plate. If necessary, rotate the bushing backup plate to align with the bushing holes. Insert bushing screws, with washers installed in the unthreaded holes in the bushing. Tighten screws lightly.
- Alternately and evenly tighten the screws in the bushing nearest the equipment to the recommended torque given in Table 1. Repeat procedure on outer bushing.

Bushing Removal for Standard Taper or Short Shaft Bushings:

1. Remove bushing screws.
2. Place the screws in the threaded holes provided in the bushing flanges. Tighten the screws alternately and evenly until the bushings are free on the shaft. For ease of tightening screws make sure screw threads and threaded holes in the bushing flanges are clean. If the reducer was positioned closer than the recommended minimum distance "A" as shown in Table 1, loosen the inboard bushing screws until they are clear of the bushing flange by 1/8". Locate two (2) wedges at 180 degrees between the bushing flange and the bushing backup plate. Drive the wedges alternately and evenly until the bushing is free on the shaft.
3. Remove the outside bushing, the reducer, and then the inboard bushing.

LUBRICATION

IMPORTANT: Because reducer is shipped without oil, it is necessary to add the proper amount of oil before operating reducer. Use a high-grade petroleum base rust and oxidation inhibited (R&O) gear oil (Tables 2 and 3). Follow instructions on reducer warning tags, and in the installation manual.

For average industrial operating conditions, the lubricant should be changed every 2500 hours of operation or every 6 months, whichever occurs first. Drain reducer and flush with kerosene, clean magnetic drain plug and refill to proper level with new lubricant.

CAUTION: Too much oil will cause overheating and too little will result in gear failure. Check oil level regularly. Failure to observe this precaution could result in bodily injury.

Under extreme operating conditions, such as rapid rise and fall of temperature, dust, dirt, chemical particles, chemical fumes, or oil sump temperatures above 200°F, the oil should be changed every 1 to 3 months, depending on severity of conditions.

Table 2—Oil Volumes

Approximate Reducer Size		Volume of Oil to Fill Reducer to Oil Level Plug ❶❷											
		❸Position A		❸Position B		❸Position C		❸Position D		❸Position E		❸Position F	
		❹Qt	L	❹Qt	L	❹Qt	L	❹Qt	L	❹Qt	L	❹Qt	L
TA0107L	Single	0.7	0.6	0.5	0.5	0.7	0.6	1.4	1.3	1.3	1.2	1.5	1.4
	Double	0.7	0.6	0.5	0.5	0.6	0.6	1.3	1.3	1.2	1.2	1.4	1.3
TA1107H	Single	1.3	1.3	0.7	0.7	0.7	0.6	1.7	1.6	1.5	1.4	1.9	1.8
	Double	1.3	1.3	0.7	0.7	0.6	0.6	1.7	1.6	1.5	1.4	1.9	1.8
TA2115H	Single	2.1	2.0	1.2	1.2	1.1	1.0	2.7	2.5	2.3	2.2	3.1	2.8
	Double	2.1	2.0	1.1	1.1	1.0	1.0	2.6	2.5	2.4	2.3	3.0	2.9
TA3203H	Single	2.8	2.7	1.6	1.6	1.8	1.7	4.1	3.9	3.3	3.1	4.4	4.2
	Double	2.8	2.7	1.5	1.4	1.7	1.6	4.0	3.8	3.4	3.3	4.2	4.0
TA4207H	Single	4.4	4.2	2.6	2.5	2.9	2.8	7.4	7.0	6.3	6.0	7.8	7.3
	Double	4.4	4.2	2.5	2.4	2.8	2.6	7.3	6.9	6.4	6.0	7.5	7.1
TA5215H	Single	7.4	7.0	4.9	4.7	5.8	5.5	13.2	12.5	11.6	11.0	13.1	12.4
	Double	7.4	7.0	4.7	4.4	5.5	5.2	12.9	12.2	11.4	10.8	12.6	11.9
TA6307H	Single	8.8	8.4	5.8	5.5	6.6	6.2	16.1	15.3	13.2	12.5	16.1	15.3
	Double	8.8	8.4	5.5	5.2	6.2	5.9	15.8	15.0	13.9	13.1	15.3	14.5
TA7315H	Single	8.4	8.0	11.8	11.1	13.9	13.2	22.5	21.3	22.1	20.9	25.1	23.7
	Double	8.4	8.0	10.8	10.3	13.2	12.5	22.0	20.9	22.4	21.2	23.1	21.8
TA8407H	Single	N/A	N/A	N/A	N/A	N/A	N/A	N/A	N/A	N/A	N/A	N/A	N/A
	Double	7.7	7.3	11.7	11.1	13.7	12.9	25.1	23.8	24.0	22.7	25.8	24.4
TA9415H	Single	N/A	N/A	N/A	N/A	N/A	N/A	N/A	N/A	N/A	N/A	N/A	N/A
	Double	17.0	16.1	16.8	15.9	18.1	17.1	33.2	31.4	33.2	31.4	38.6	36.5
TA10507H	Single	N/A	N/A	N/A	N/A	N/A	N/A	N/A	N/A	N/A	N/A	N/A	N/A
	Double	38.0	36.0	27.6	26.1	25.8	24.4	53.5	50.6	53.8	50.9	56.1	53.0
TA12608H	Single	N/A	N/A	N/A	N/A	N/A	N/A	N/A	N/A	N/A	N/A	N/A	N/A
	Double	53.0	50.2	41.5	39.3	37.1	35.1	70.7	66.9	72.2	68.3	80.4	76.1

- ❶ Oil quantity is approximate. Service with lubricant until oil runs out of oil level hole.
- ❷ Refer to Figure 1 for mounting positions.
- ❸ US measure: 1 quart = 32 fluid ounces = .94646 liters.
- ❹ Below 15 RPM output speed, oil level must be adjusted to reach the highest oil level plug. If reducer position is to vary from those shown in Figure 1, either more or less oil may be required. Consult Baldor Electric Company, Dodge Engineering, Greenville, SC.

Table 3 – Oil Recommendations

Output RPM	ISO Grades For Ambient Temperatures of 50° F to 125° F *											
	Torque-Arm II Reducer Size											
	TA0107L	TA1107H	TA2115H	TA3203H	TA4207H	TA5215H	TA6307H	TA7315H	TA8407H	TA9415H	TA10507H	TA12608H
301 – 400	320	320	320	220	220	220	220	220	220	220	220	220
201 – 300	320	320	320	220	220	220	220	220	220	220	220	220
151 – 200	320	320	320	220	220	220	220	220	220	220	220	220
126 – 150	320	320	320	220	220	220	220	220	220	220	220	220
101 – 125	320	320	320	320	220	220	220	220	220	220	220	220
81 – 100	320	320	320	320	320	220	220	220	220	220	220	220
41 – 80	320	320	320	320	320	220	220	220	220	220	220	220
11 – 40	320	320	320	320	320	320	320	320	320	320	220	220
1 – 10	320	320	320	320	320	320	320	320	320	320	320	320

Output RPM	ISO Grades For Ambient Temperatures of 15° F to 60° F *											
	Torque-Arm II Reducer Size											
	TA0107L	TA1107H	TA2115H	TA3203H	TA4207H	TA5215H	TA6307H	TA7315H	TA8407H	TA9415H	TA10507H	TA12608H
301 – 400	220	220	220	150	150	150	150	150	150	150	150	150
201 – 300	220	220	220	150	150	150	150	150	150	150	150	150
151 – 200	220	220	220	150	150	150	150	150	150	150	150	150
126 – 150	220	220	220	150	150	150	150	150	150	150	150	150
101 – 125	220	220	220	220	150	150	150	150	150	150	150	150
81 – 100	220	220	220	220	220	150	150	150	150	150	150	150
41 – 80	220	220	220	220	220	150	150	150	150	150	150	150
11 – 40	220	220	220	220	220	220	220	220	220	220	150	150
1 – 10	220	220	220	220	220	220	220	220	220	220	220	220

NOTES:

1. Assumes auxiliary cooling where recommended in the catalog.
2. Pour point of lubricant selected should be at least 10°F lower than expected minimum ambient starting temperature.
3. Extreme pressure (EP) lubricants are not necessary for average operating conditions. When properly selected for specific applications, TORQUE-ARM II backstops are suitable for use with EP lubricants.
4. Special lubricants may be required for food and drug industry applications where contact with the product being manufactured may occur. Consult a lubrication manufacturer's representative for his recommendations.
5. For reducers operating in ambient temperatures between -22°F (-30°C) and 20°F (-6.6°C) use a synthetic hydrocarbon lubricant, 100 ISO grade or AGMA 3 grade (for example, Mobil SHC627). Above 125°F (51°C), consult Baldor Electric Company, Dodge Gear Application Engineering, Greenville, SC for lubrication recommendation.
6. Mobil SHC630 Series oil is recommended for high ambient temperatures.

GUIDELINES FOR TORQUE-ARM II REDUCER LONG-TERM STORAGE

During periods of long storage, or when waiting for delivery or installation of other equipment, special care should be taken to protect a gear reducer to have it ready to be in the best condition when placed into service.

By taking special precautions, problems such as seal leakage and reducer failure due to lack of lubrication, improper lubrication quantity, or contamination can be avoided. The following precautions will protect gear reducers during periods of extended storage:

Preparation:

1. Drain oil from the unit. Add a vapor phase corrosion inhibiting oil (VCI-105 oil by Daubert Chemical Co.) in accordance with Table 4.
2. Seal the unit airtight. Replace the vent plug with a standard pipe plug and wire the vent to the unit.
3. Cover all unpainted exterior parts with a waxy rust preventative compound that will keep oxygen away from the bare metal. (Non-Rust X-110 by Daubert Chemical Co. or equivalent).
4. The instruction manuals and lubrication tags are paper and must be kept dry. Either remove these documents and store them inside, or cover the unit with a durable waterproof cover which can keep moisture away.
5. Protect reducer from dust, moisture, and other contaminants by storing the unit in a dry area.

6. In damp environments, the reducer should be packed inside a moisture-proof container or an envelope of polyethylene containing a desiccant material. If the reducer is to be stored outdoors, cover the entire exterior with a rust preventative.

When placing the reducer into service:

1. Fill the unit to the proper oil level using a recommended lubricant. The VCI oil will not affect the new lubricant.
2. Clean the shaft extensions with petroleum solvents.
3. Assemble the vent plug into the proper hole.

Follow the installation instructions provided in this manual.

Table 4 – Quantities of VCI #105 Oil

Reducer Size	Quantity (Ounces / Milliliter)
TA0107L	1 / 30
TA1107H	1 / 30
TA2115H	1 / 30
TA3203H	1 / 30
TA4207H	1 / 30
TA5215H	2 / 59
TA6307H	2 / 59
TA7315H	3 / 89
TA8407H	3 / 89
TA9415H	4 / 118
TA10507H	6 / 177
TA12608H	8 / 237

VCI #105 and #10 are interchangeable. VCI #105 is more readily available.

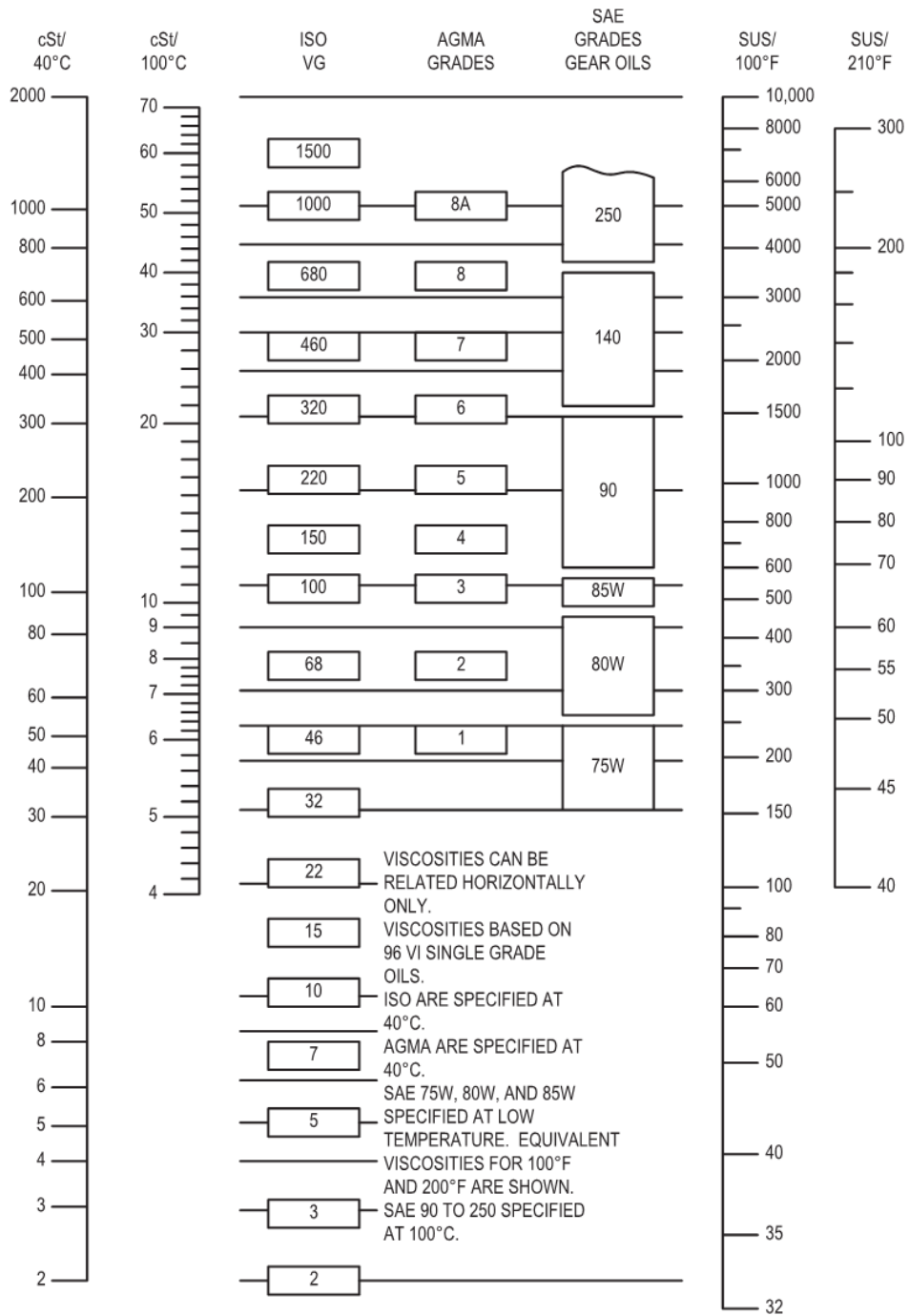

Figure 7 - OIL VISCOSITY EQUIVALENCY CHART

4B Slack Chain Sensor



WDA Sensor

**BELT ALIGNMENT / MOTION &
BROKEN / SLACK CHAIN MONITOR**



INSTALLATION INSTRUCTIONS

OPERATION MANUAL

Part No. WDA3V34C

www.go4b.com/usa

⚠ WARNING



Moving parts can crush and cut.

Lockout power before removing guard or servicing.

Do NOT operate with guard removed

⚠ DANGER



Exposed buckets and moving parts will cause severe injury or death.

Lockout power before removing cover or inspection door.

⚠ DANGER



Exposed moving parts will cause severe injury or death.

Lockout power before removing cover or inspection door.

⚠ DANGER



Exposed rotating parts will cause severe injury or death.

Lockout power before removing cover or inspection door.

TABLE OF CONTENTS

CUSTOMER SAFETY RESPONSIBILITIES	Page 4 - 5
PRODUCT OVERVIEW	Page 6
SPECIFICATIONS	Page 6
DIMENSIONS	Page 7
INSTALLATION - BUCKET ELEVATOR	Page 8
BUCKET ELEVATOR PLACEMENT DIAGRAMS	Page 9 - 12
INSTALLATION - CONVEYORS	Page 13 - 14
STANDARD WIRING DIAGRAMS	Page 15 - 16
TESTING & COMMISSIONING	Page 17
SENSOR CALIBRATION	Page 17
TROUBLESHOOTING GUIDE	Page 17
PARTS & ACCESSORIES	Page 18
PRODUCT WARRANTY	Page 19

Dear 4B Customer:

Congratulations on your purchase. 4B appreciates your business and is pleased you have chosen our products to meet your needs.

Please read in its entirety and understand the literature accompanying the product before you place the product into service. Please read the safety precautions carefully before operating the product. With each product you purchase from 4B, there are some basic but important safety considerations you must follow to be sure your purchase is permitted to perform its design function and operate properly and safely, giving you many years of reliable service. Please read and understand the Customer Safety Responsibilities listed below. Failure to follow this safety directive and the Operation Manuals and other material furnished or referenced, may result in serious injury or death.

SAFETY NOTICE TO OUR CUSTOMERS

- A. In order to maximize efficiency and safety, selecting the right equipment for each operation is vital. The proper installation of the equipment, and regular maintenance and inspection is equally important in continuing the proper operation and safety of the product. The proper installation and maintenance of all our products is the responsibility of the user unless you have asked 4B to perform these tasks.
- B. All installation and wiring must be in accordance with Local and National Electrical Codes and other standards applicable to your industry. (Please see the article "Hazard Monitoring Equipment Selection, Installation and Maintenance" at www.go4b.com.) The installation of the wiring should be undertaken by an experienced and qualified professional electrician. Failure to correctly wire any product and/or machinery can result in the product or machine failing to operate as intended, and can defeat its design function.
- C. Periodic inspection by a qualified person will help assure your 4B product is performing properly. 4B recommends a documented inspection at least annually and more frequently under high use conditions.
- D. Please see the last page of this manual for all warranty information regarding this product.

CUSTOMER SAFETY RESPONSIBILITIES

1. READ ALL LITERATURE PROVIDED WITH YOUR PRODUCT

Please read all user, instruction and safety manuals to ensure that you understand your product operation and are able to safely and effectively use this product.

2. YOU BEST UNDERSTAND YOUR NEEDS

Every customer and operation is unique, and only you best know the specific needs and capabilities of your operation. Please call the 24-hour hotline at 309-698-5611 for assistance with any questions about the performance of products purchased from 4B. 4B is happy to discuss product performance with you at any time.

3. SELECT A QUALIFIED AND COMPETENT INSTALLER

Correct installation of the product is important for safety and performance. If you have not asked 4B to perform the installation of the unit on your behalf, it is critical for the safety of your operation and those who may perform work on your operation that you select a qualified and competent electrical installer to undertake the installation. The product must be installed properly to perform its designed functions. The installer should be qualified, trained, and competent to perform the installation in accordance with Local and National Electrical Codes, all relevant OSHA Regulations, as well as any of your own standards and preventive maintenance requirements, and other product installation information supplied with the product. You should be prepared to provide the installer with all necessary installation information to assist in the installation.

4. ESTABLISH AND FOLLOW A REGULAR MAINTENANCE AND INSPECTION SCHEDULE FOR YOUR 4B PRODUCTS

You should develop a proper maintenance and inspection program to confirm that your system is in good working order at all times. You will be in the best position to determine the appropriate frequency for inspection. Many different factors known to the user will assist you in deciding the frequency of inspection. These factors may include but are not limited to weather conditions; construction work at the facility; hours of operation; animal or insect infestation; and the real-world experience of knowing how your employees perform their jobs. The personnel or person you select to install, operate, maintain, inspect or perform any work whatsoever, should be trained and qualified to perform these important functions. Complete and accurate records of the maintenance and inspection process should be created and retained by you at all times.

5. RETAIN AND REFER TO THE OPERATION MANUAL FOR 4B'S SUGGESTED MAINTENANCE AND INSPECTION RECOMMENDATIONS

As all operations are different, please understand that your specific operation may require additional adjustments in the maintenance and inspection process essential to permit the monitoring device to perform its intended function. Retain the Operation Manual and other important maintenance and service documents provided by 4B and have them readily available for people servicing your 4B equipment. Should you have any questions, please call the free 24-hour hotline number (309-698-5611).

6. SERVICE REQUEST

If you have questions or comments about the operation of your unit or require the unit to be serviced please contact the 4B location who supplied the product or send your request via fax (309-698-5615) or call us via our 24-hour hotline number in the USA (309-698-5611). Please have available product part numbers, serial numbers, and approximate date of installation. In order to assist you, after the product has been placed into service, complete the online product registration section which is accessed via our website www.go4b.com/usa.

OVERVIEW

The 4B WDA sensor is designed to detect moving ferrous (magnetic) material passing within its sensing range, and is used in conjunction with a speed relay, PLC or with 4B's Watchdog™ Elite and A400 Elite control units. The sensor will not detect non-ferrous material such as plastic, rubber, stainless steel or aluminium.

The WDA can detect ferrous steel elevator buckets from the side of the elevator leg, or through the elevator belt from the back of the leg. For plastic elevator buckets, the steel elevator bolts used to attach the buckets can be targeted by installing the WDA on the back of the leg.

A more specialized use for the WDA switch is as a broken/slack chain detector on drag chain conveyors, or as a non-contact speed switch for screw conveyors.

A flashing LED on the end of the sensor indicates a target has been detected. A potentiometer control screw, located below the LED, allows the target sensing range to be adjusted from 1 to 3 inches. Two output signals are provided: one signal is a pulse output, representing each object detected; the second signal is a continuous output when moving objects are detected (see wiring diagram).

SPECIFICATIONS

Voltage -	12 to 24 VDC \pm 10%
Supply Current -	65 mA
LED Indicator -	Green (Flashing) - Target Detected Green (Off) - No Target Detected
Outputs (Max) -	1. 100 mA Sink 2. 50 mA Source
Detection Range -	Adjustable: 1 - 3 Inches (25 - 75 mm) for 1 Inch Diameter Ferrous Target
Detection Rate -	20 - 2,000 PPM (Pulses Per Minute)
Cable -	9 ft. Long - 6 Conductor
Conduit Entry -	1/2 Inch NPT
Temperature Rating -	-4° F to 122° F (-20° C to 50° C)
Protection -	IP66
Approvals -	CSA Class II Div. 1 Groups E, F, & G (USA and Canada) CE, ATEX & IECEX Versions Available (Europe)

- Specifications for part # WDA3V34C, high temperature version also available (HTAS1V34)

NOTE

The WDA3V34C contains a non-repairable 160 mA fuse and two thermal fuses set at 164°F (73°C). Should the sensor reach the set temperature or higher, one or both of the thermal fuses may fail. The expected maximum ambient temperature of the sensor is 122°F (50°C).

DIMENSIONS

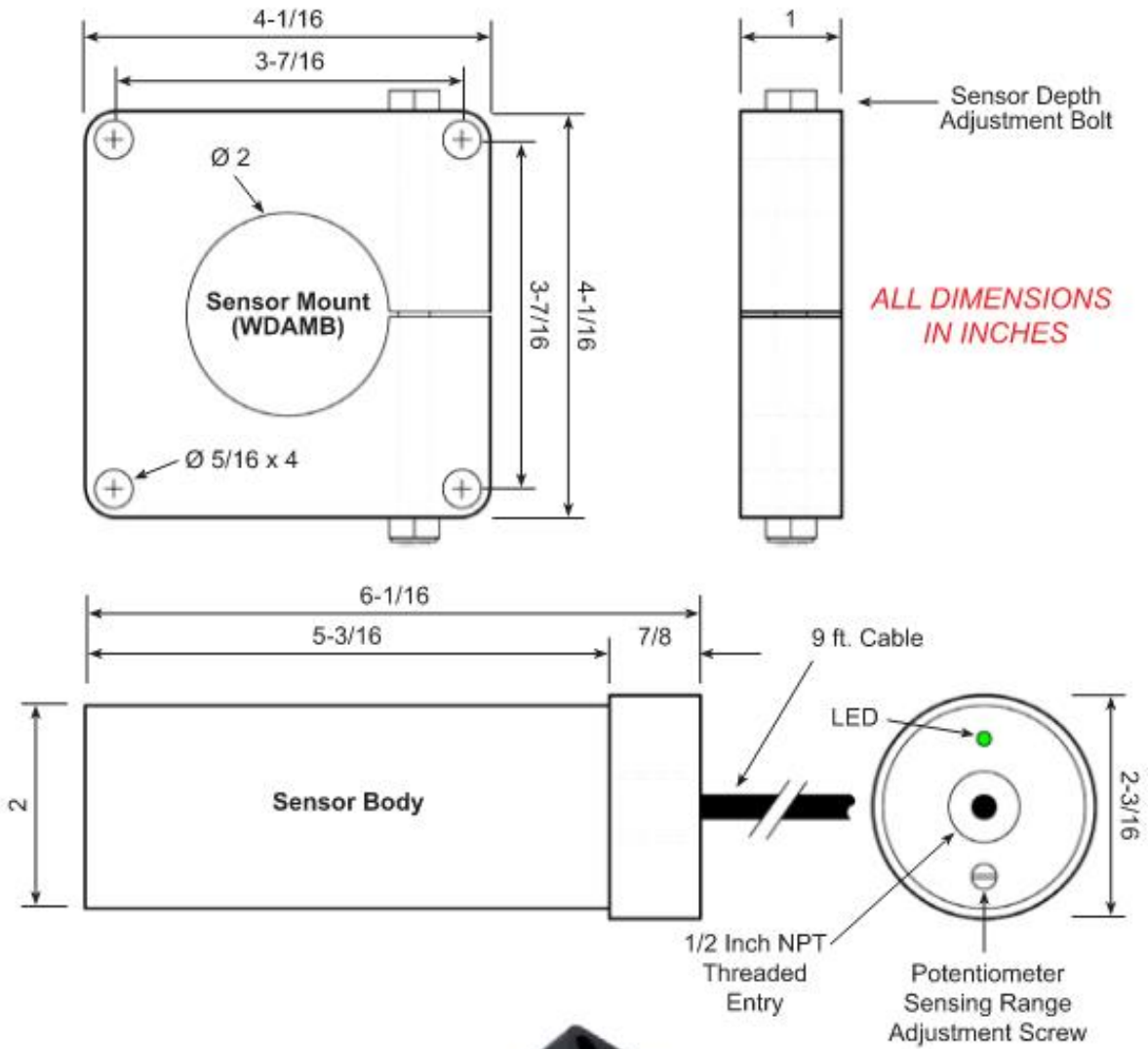

INSTALLATION - CONVEYORS

SCREW CONVEYOR -

For speed monitoring on a screw conveyor, the sensor will need to detect a ferrous steel flight (target). If the housing is mild steel, cut a 4 inch or larger diameter hole in the housing and weld a 300 series stainless steel plate over the hole. Make sure that the plate is larger than the WDA's mounting bracket, and mount the WDA sensor to the stainless steel plate. The sensor should be mounted 1-3 inches away from the edge of the hole in the housing or it may detect the mild steel as a false target. Since 300 series stainless steel is non-ferrous, the sensor will not be affected as the sensing field can pass through the plate.

If the housing is 300 series stainless steel, no hole is required, mount the WDA3 sensor directly to the housing. The sensor should be mounted 1-3 inches away from the moving ferrous flight (target) but over 3 inches away from the rotating shaft. This installation is very similar to option 1 for drag conveyors.

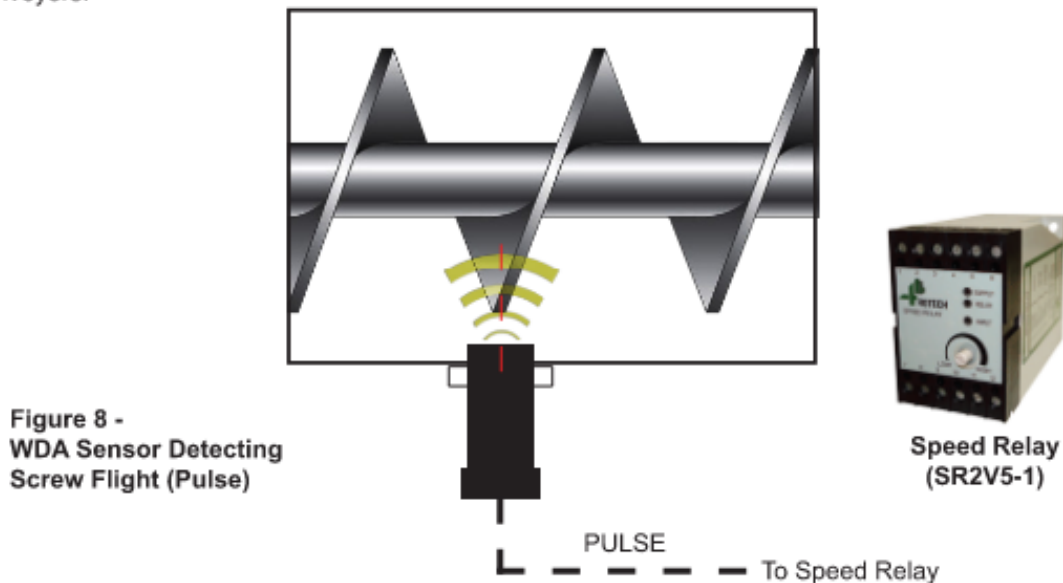

**Figure 8 -
WDA Sensor Detecting
Screw Flight (Pulse)**

**Speed Relay
(SR2V5-1)**

DRAG CONVEYOR -

For slack/broken chain detection on drag conveyors, the WDA sensor can be installed using one of three options (see below). Either a hole can be cut in the conveyor housing for the sensor, or the mount can be installed on a stainless steel plate welded directly to the conveyor housing over the hole. Since stainless steel is non-ferrous, the sensor will not be affected as the sensing field can pass through the plate.

Once the proper placement has been identified, cut a 2-1/4 inch (57 mm) diameter hole in the drag conveyor housing for each sensor. If using stainless steel plate, the hole diameter may need to be larger.

The WDA sensor can be mounted using one of the following three methods -

1. Drill and tap the machine casing for 5/16 inch threaded bolts. Make sure that the bolts used to secure the sensor mounting bracket are short enough that they do not interfere with the operation of the machine.
2. Use threaded rivet nuts for 5/16 inch threads. The length of the rivet nut will depend on the thickness of the machine's casing. Make sure that the bolts used to secure the sensor mounting bracket are short enough that they do not interfere with the operation of the machine.
3. CD weld 5/16 inch threaded welding studs to the machine casing.

To drill the four 5/16 inch bolt holes for the sensor mounting bracket, use the supplied paper template from the sensor manual or use the bracket itself, by centering on the existing 2-1/4 inch (57 mm) hole.

OPTION 1: SENSOR DETECTING TARGET ON PADDLE -

Under normal running conditions, the target bolt passes through the sensor's field and a pulse is sent to the speed relay. If the chain becomes slack, the target bolt will drop below the field and the pulses will stop, causing the relay contact to change state.

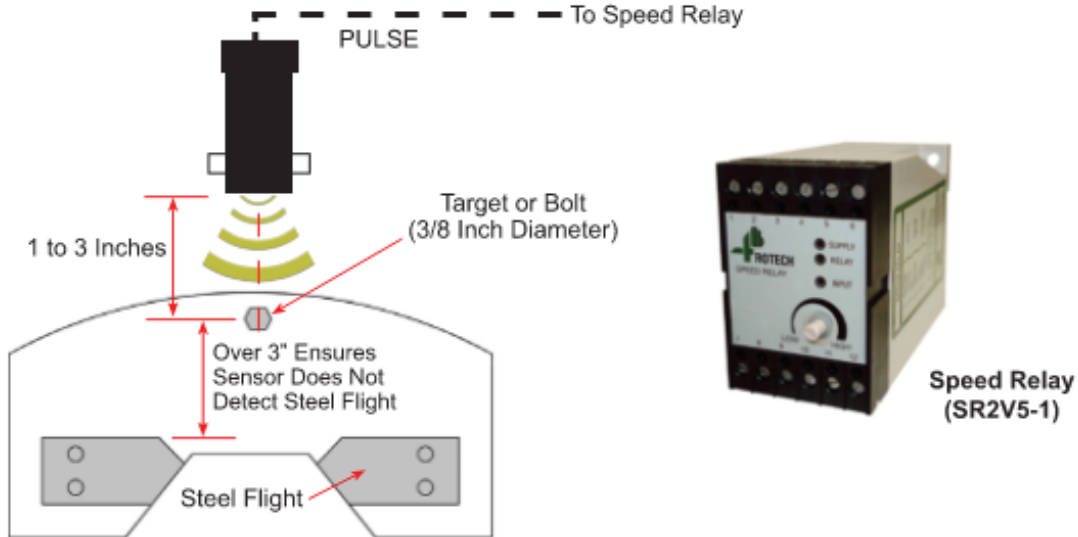

OPTION 2: SENSOR DETECTING STEEL FLIGHT -

Under normal running conditions, the steel flight passes through the sensor's field and a pulse is sent to the speed relay. If the chain becomes slack, the steel flight will drop below the field and the pulses will stop, causing the relay contact to change state.

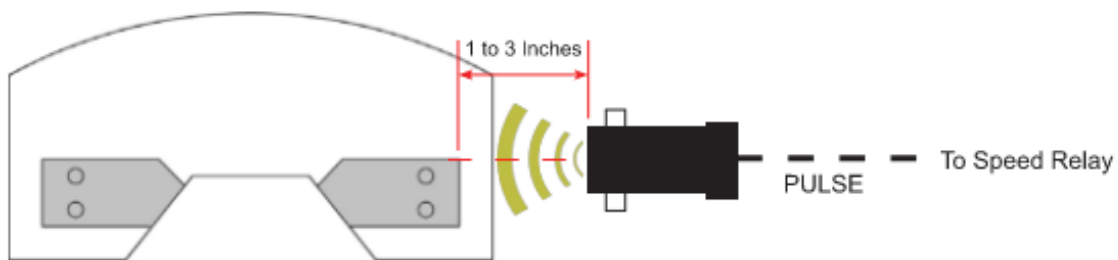

OPTION 3: SENSOR WAITING TO DETECT STEEL FLIGHT -

Under normal running conditions, the steel flight is out of the sensor's field, so no pulses are sent to the speed relay. If the chain becomes slack, the steel flight comes into the sensor's field and a pulse is sent to the speed relay, causing it to change state.

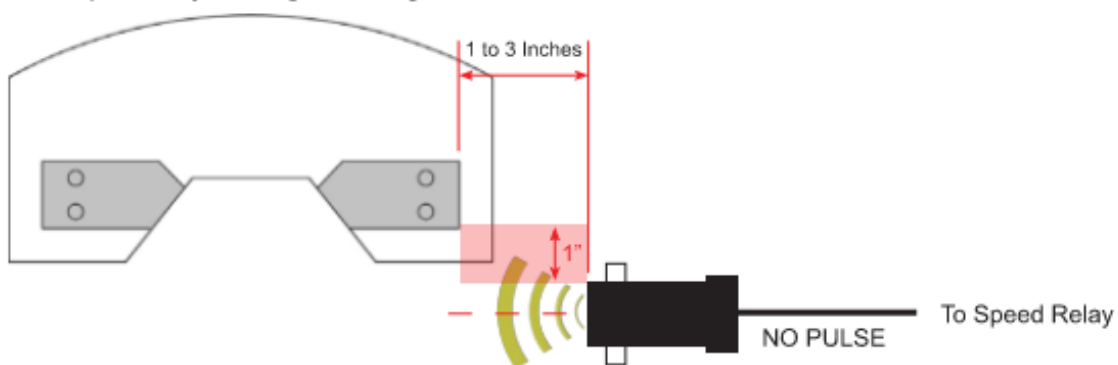

NOTE

The sensor depth can be adjusted by loosening the adjustment bolt on the mounting bracket, sliding the sensor to the required depth and retightening the bolt. Final sensitivity adjustments should be made using the potentiometer sensing range adjustment screw.

⚠ WARNING

Ensure that no ferrous steel, such as the machine's frame is within the target sensing field. This can interfere with the sensor detecting the intended target.

STANDARD WIRING DIAGRAM

All wiring must be in accordance with local and national electrical codes and should be undertaken by an experienced and qualified electrician.

Always use dust/liquid tight flexible metal conduit with approved fittings to protect the sensor cables. Use rigid metal conduit to protect the cables from the sensors to the control unit. Conduit systems can channel water due to ingress and condensation directly to sensors and sensor connections which over time will adversely affect the performance of the system. As such, the installation of low point conduit drains is recommended for all sensors.

RED	+ Supply, 12 to 24 VDC \pm 10%
BLACK	- Supply, 0 VDC
GREEN	Ground Connection
YELLOW / ORANGE	Control Signal 0 VDC to + VDC
BLUE	Pulsed Output. Normally Low, High When Detecting
WHITE	Continuous Output. Low when detecting, high when stopped for 2.5 seconds

To use the internal potentiometer within the WDA sensor, connect the YELLOW/ORANGE wire to the RED wire. Turn the sensing range adjustment screw clockwise to increase the sensing range.

NOTE

If using the A400 Elite Trackswitch control unit, follow the wiring instructions for YELLOW/ORANGE wire as detailed in the A400 manual. Make sure to turn the sensing range adjustment screw on the WDA sensor fully counter-clockwise when using the A400.

If using the Watchdog™ Elite control unit, connect the YELLOW/ORANGE wire to the RED wire. Turn the sensing range adjustment screw clockwise to increase the sensing range.

UPDATING FROM DISCONTINUED WDA1 MODEL -

If you are updating from the older and discontinued WDA1 (plastic body) to the current WDA sensor (stainless steel body), the wiring process is outline below:

WDA3	WDA1
RED	BROWN: +Supply VDC
BLACK	BLUE: - Supply VDC
GREEN	GREEN: Ground
YELLOW / ORANGE	----- Control
BLUE	BLACK: Pulsed Output
WHITE	----- Continuous Output

SPEED RELAY WIRING DIAGRAM (SIMPLIFIED) -

The diagram below is a simplified wiring diagram for connecting the WDA sensor to a 4B Rotech Speed Relay (Model SR2V5-1). See speed relay and other applicable instructions for complete set-up and installation information.

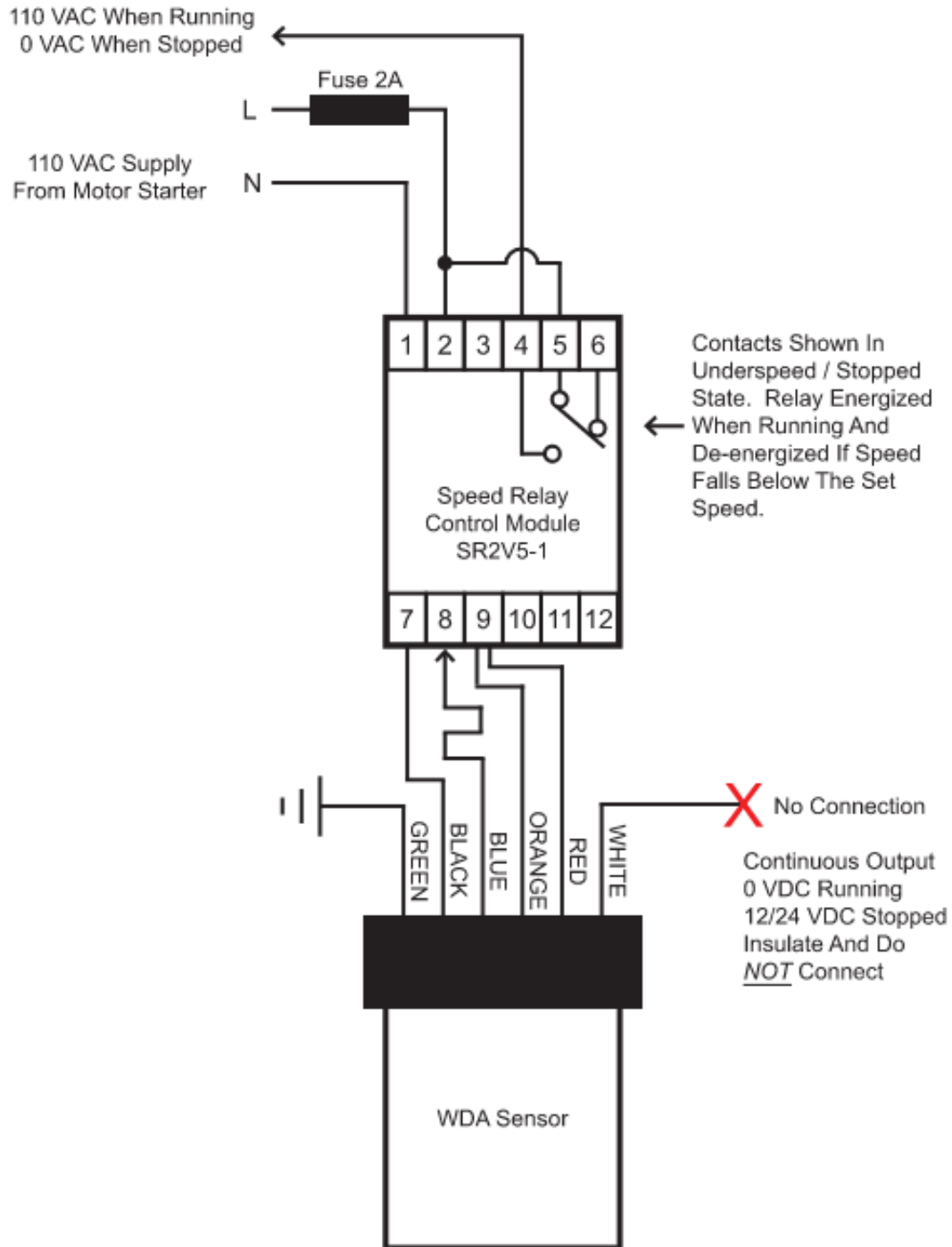

SENSOR CALIBRATION

Turn the sensing range adjustment screw fully clockwise while machine is running, the green LED should flash consistently. Slowly turn the sensing range adjustment screw counter-clockwise until the flashing becomes irregular. Then turn it slowly clockwise until a regular flashing pattern appears, add an extra 1/8th turn clockwise for range compensation.

TESTING AND COMMISSIONING

1. Check that the unit is correctly installed (see standard wiring diagram).
2. Check that the distance between the target and the sensing face of the WDA sensor is within the minimum distance specified.
3. Start up machine, the green LED shows the state of the pulsed output and flashes once for each target detected. The LED should be off when no target is detected, if not, reduce the sensitivity
4. If the sensor is not performing as expected, contact 4B.

WARNING

If the system does not alarm as required, then remove the machine from service until the problem has been diagnosed and corrected.

TROUBLESHOOTING GUIDE

FAULT	CAUSE	REMEDY
LED on alignment sensor does not flash	<ol style="list-style-type: none"> 1. Sensor too far away from target 2. Sensor adjustment incorrect 3. Faulty wire connection 4. Object stuck to magnetic face of the sensor, causing interference 	<ol style="list-style-type: none"> 1. Move sensor closer to target 2. Turn sensitivity control clockwise 3. Check wiring 4. Remove object
LED on alignment sensor flashes excessively	<ol style="list-style-type: none"> 1. Sensor too close to target 2. Sensor adjustment incorrect 3. Interference in wiring 	<ol style="list-style-type: none"> 1. Move sensor away from target 2. Turn sensitivity control counter clockwise 3. Use shielded cable and rigid conduit
Sensor will not calibrate	Wiring issue	<ol style="list-style-type: none"> 1. Make sure that the YELLOW/ ORANGE wire is connected to the RED wire 2. Make sure that the YELLOW/ ORANGE wire is connected to the correct input on the controller

PARTS & ACCESSORIES



Watchdog™ Super Elite Hazard Monitoring Control System

The Watchdog Super Elite is a microprocessor controlled unit with combined belt speed, belt alignment, bearing temperature, pulley alignment and plugged condition monitoring for bucket elevators and conveyors. A 3.5" LCD screen displays the entire system status at a glance.

A400 Elite Trackswitch Belt Alignment Monitor

The A400 Elite Trackswitch belt misalignment monitor uses 4B WDA magnetic proximity sensors to monitor the alignment of the belt in bucket elevators. Each control unit incorporates two independent monitoring circuits for early detection of belt misalignment on one or two bucket elevators.



WDA High Temperature Sensor (HTAS1V34)

Non-contacting extended range magnetic proximity sensor, not affected by dust or material build up, used to detect moving ferrous material up to 3 inches away from the sensor. Designed for temperatures ranging from 302° F (continuous) to 356° F (maximum).



Speed Relay (SR2V5-1)

DIN rail mounted speed relay with a user adjustable underspeed relay contact output that can sound an alarm or shutdown machinery when the shaft speed falls below the preset level.

WDA Sensor Mount (WDAMB)

Plastic mount for the WDA sensor (included with sensor).



PRODUCT WARRANTY

1. EXCLUSIVE WRITTEN LIMITED WARRANTY

ALL PRODUCTS SOLD ARE WARRANTED BY THE COMPANY 4B COMPONENTS LIMITED AND 4B BRAIME COMPONENTS LIMITED HEREIN AFTER REFERRED TO AS 4B TO THE ORIGINAL PURCHASER AGAINST DEFECTS IN WORKMANSHIP OR MATERIALS UNDER NORMAL USE FOR ONE (1) YEAR AFTER DATE OF PURCHASE FROM 4B. ANY PRODUCT DETERMINED BY 4B AT ITS SOLE DISCRETION TO BE DEFECTIVE IN MATERIAL OR WORKMANSHIP AND RETURNED TO A 4B BRANCH OR AUTHORIZED SERVICE LOCATION, AS 4B DESIGNATES, SHIPPING COSTS PREPAID, WILL BE, AS THE EXCLUSIVE REMEDY, REPAIRED OR REPLACED AT 4B'S OPTION.

2. DISCLAIMER OF IMPLIED WARRANTY

NO WARRANTY OR AFFIRMATION OF FACT, EXPRESSED OR IMPLIED, OTHER THAN AS SET FORTH IN THE EXCLUSIVE WRITTEN LIMITED WARRANTY STATEMENT ABOVE IS MADE OR AUTHORIZED BY 4B. 4B SPECIFICALLY DISCLAIMS ANY LIABILITY FOR PRODUCT DEFECT CLAIMS THAT ARE DUE TO PRODUCT MISUSE, ABUSE OR MISAPPLICATIONS, AS AUTHORIZED BY LAW, 4B SPECIFICALLY DISCLAIMS ALL WARRANTIES THAT THE PRODUCT IS FIT OR MERCHANTABLE FOR A PARTICULAR PURPOSE.

3. NO WARRANTY "BY SAMPLE OR EXAMPLE"

ALTHOUGH 4B HAS USED REASONABLE EFFORTS TO ACCURATELY ILLUSTRATE AND DESCRIBE THE PRODUCTS IN ITS CATALOGS, LITERATURE, AND WEBSITES, SUCH ILLUSTRATIONS AND DESCRIPTIONS ARE FOR THE SOLE PURPOSE OF PRODUCT IDENTIFICATION AND DO NOT EXPRESS OR IMPLY A WARRANTY AFFIRMATION OF FACT, OF ANY KIND OR A WARRANTY OR AFFIRMATION OF FACT THAT THE PRODUCTS WILL CONFORM TO THEIR RESPECTIVE ILLUSTRATIONS OR DESCRIPTIONS. 4B EXPRESSLY DISCLAIMS ANY WARRANTY OR AFFIRMATION OF FACT, EXPRESSED OR IMPLIED, OTHER THAN AS SET FORTH IN THE EXCLUSIVE WRITTEN LIMITED WARRANTY STATEMENT ABOVE, INCLUDING, WITHOUT LIMITATION, THE IMPLIED WARRANTIES OF MERCHANTABILITY AND FITNESS FOR A PARTICULAR PURPOSE.

4. LIMITATION OF DAMAGES

ANY LIABILITY FOR CONSEQUENTIAL, INCIDENTAL, SPECIAL, EXEMPLARY, OR PUNITIVE DAMAGES, OR FOR LOSS OF PROFIT WHETHER DIRECT OR INDIRECT, IS EXPRESSLY DISCLAIMED.

With subsidiaries in North America, Europe, Asia, Africa and Australia along with a worldwide network of distributors, 4B can provide practical solutions for all your applications no matter the location.



4B BRAIME COMPONENTS

Hunslet Road
Leeds
LS10 1JZ
United Kingdom
Tel: +44 (0) 113 246 1800
Fax: +44 (0) 113 243 5021

4B DEUTSCHLAND

9 Route de Corbie
Lamotte Warfusée
F-80800
France
Tel: +49 (0) 700 2242 4091
Fax: +49 (0) 700 2242 3733

4B ASIA PACIFIC

Build No. 899/1 Moo 20
Soi Chongsiri, Bangplee-Tam Ru Road,
Tanbon Bangpleeyai, Amphur Bangplee,
Samutprakarn 10540
Thailand
Tel: +66 (0) 2 173-4339
Fax: +66 (0) 2 173-4338

4B COMPONENTS LTD.

625 Erie Avenue
Morton, IL 61550
USA
Tel: 309-698-5611
Fax: 309-698-5615

4B FRANCE

9 Route de Corbie
80800 Lamotte Warfusée
France
Tel: +33 (0) 3 22 42 32 26
Fax: +33 (0) 3 22 42 37 33

4B AFRICA

14 Newport Business Park
Mica Drive, Kya Sand
2163 Johannesburg
South Africa
Tel: +27 (0) 11 708 6114
Fax: +27 (0) 11 708 1654

4B AUSTRALIA

Unit 1/18 Overlord Place
Acacia Ridge
Queensland 4110
Australia
Tel: +61 (0) 7 3711 2565
Fax: +61 (0) 7 3711 2574

www.go4b.com

4B Level Indicator



Product Datasheet

Binswitch

BETTER BY DESIGN

Binswitch

Programmable Capacitance Point Level Indicator

APPLICATION

Detects level or plug situations in bulk granular solids or liquids.

METHOD OF OPERATION

The Binswitch Sensor detects level or plug situations for bulk granular solids or liquids in tanks, bins, or silos and can be used as a plug or choke detector in chutes, conveyors and elevator legs. A two color LED shows material present or absent.

The programmable Binswitch includes a time delay on material arriving or leaving, and fail-safe relay settings for high and low levels.

The Binswitch has a polycarbonate housing that is corrosion and abrasion resistant, dust-tight, and waterproof.

FEATURES

- ▶ Totally Sealed Construction (Submersible)
- ▶ Applications for Level or Plug Sensing
- ▶ Adjustable Sensitivity
- ▶ CSA Class II Div 1 Groups E, F & G Approved
- ▶ IP67 Protection

PART NUMBERS/ACCESSORIES

- ▶ BS1V3FC Replaced by Multi-Voltage Binswitch Elite
- ▶ BS1V4FC Replaced by Multi-Voltage Binswitch Elite
- ▶ BS1V6FC Replaced by Multi-Voltage Binswitch Elite
- ▶ BS1V10FC Replaced by Multi-Voltage Binswitch Elite
- ▶ BS2V10FC Replaced by Multi-Voltage Binswitch Elite
- ▶ BP1V10FC Programmable Binswitch (5 Wire)
- ▶ SMP Mounting Plate
- ▶ SMPS Mounting Plate (Stainless Steel)
- ▶ A34NPT 3/4 in. NPT Conduit Adapter
- ▶ BMPA 1-1/4 in. NPT Mount
- ▶ BAS Abrasion Shield (1-1/4 in. NPT Mount)
- ▶ BMPG36 Gland Mount
- ▶ BSM3 3 in. Clamp Mount

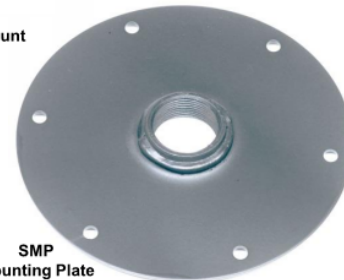

Copyright © 2015 4B Components Ltd. All rights reserved. Information is subject to change or modification without notice. Refer to instruction manual for installation information. CRD111115

4B COMPONENTS LIMITED -

625 Erie Avenue, Morton, IL 61550 USA Tel: 309-698-5611 Fax: 309-698-5615

www.go4b.com/usa



Product Datasheet

Binswitch

BETTER BY DESIGN

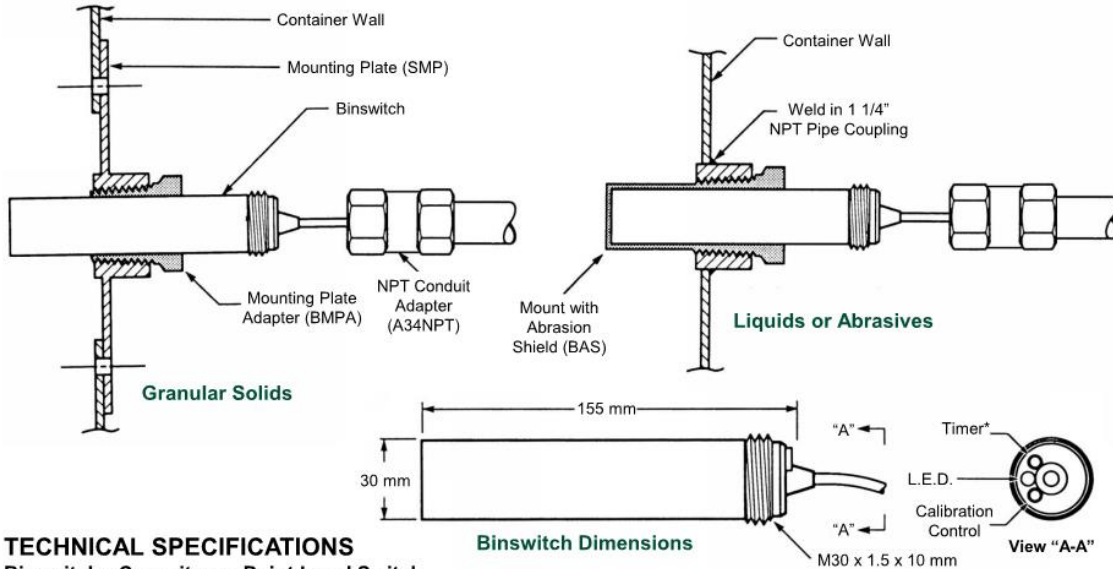

TECHNICAL SPECIFICATIONS
Binswitch - Capacitance Point Level Switch

	BP1V10FC
Power Supply:	12-240 VDC/24-240 VAC
Supply Tolerance:	N/A
Power Consumption:	50 mA
Fuse:	5 amp maximum
Operating Temp:	-22° F to +158° F
Sensing Range:	1" (25mm) typical
Output:	Programmable voltage free relay 1 pole normally open 1 pole normally closed
Contact Rating:	3 amp, 240 VAC, non-inductive
Fail-to-Safe:	High or low level fail-safe, relay de-energized material present/power failure
Calibration:	Screw potentiometer
Timer:	Programmable for "make", "break" (0-1 or 0-5 minutes)
LED Display:	Red: material present Green: material absent Red Flashing: timing material arriving Green Flashing: timing material leaving
Cable Enclosure:	6' (2m) 5 conductor cable Polycarbonate, threaded one end 30mm x 1.5mm
Protection:	IP67 - NEMA 6 and 6P Dust tight and water resistant
Approvals:	CSA Approved for Class 2 Div. 1 Groups E, F, & G (US and Canada) GOST-R (Russia)
Weight:	10.5 ounces

* Timer on Programmable Model Only

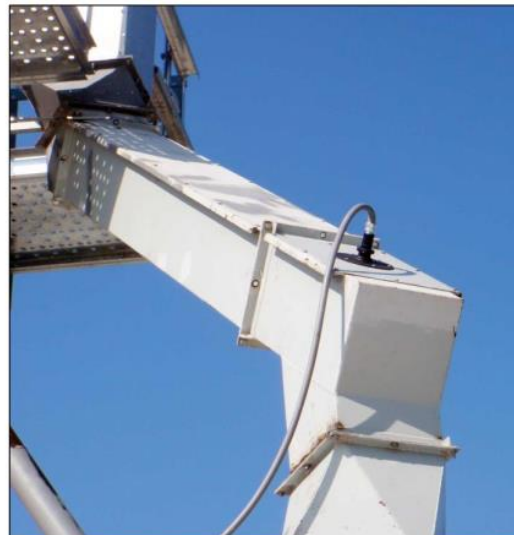

Binswitch Installed on Bucket Elevator Spouting
(With SMP, BAS & A34NPT)

Copyright © 2015 4B Components Ltd. All rights reserved. Information is subject to change or modification without notice. Refer to instruction manual for installation information. CRD111115

4B COMPONENTS LIMITED -
625 Erie Avenue, Morton, IL 61550 USA Tel: 309-698-5611 Fax: 309-698-5615

www.go4b.com/usa

4B Slip Indicator



Product Datasheet

M300 Slipswitch

BETTER BY DESIGN

M300 Slipswitch

Monitors Rotating Machinery for Dangerous Underspeed Conditions

APPLICATION

The M300 Slipswitch is a simple inductive shaft speed monitoring device. The self-contained unit has a single set point, which signals when the shaft speed has dropped by 20% of normal running speed. It is used for detecting dangerous slow down and underspeed conditions on conveyors, bucket elevators, airlocks, mixers, fans, grinders and many other machines.

METHOD OF OPERATION

An inductive sensing device located in the nose of the M300 enclosure will detect a metal target. This target can be an existing bolt head or device attached to a shaft. During installation the M300 is set to the normal machine shaft RPM by calibrating with the magnet provided. The internal microprocessor sets the underspeed output to operate at exactly 20% below normal machine shaft RPM. This allows the M300 output to be used for automatic shutdown of machinery during dangerous underspeed or belt slip conditions.

FEATURES

- ▶ Underspeed Detection at 20%
- ▶ Totally Sealed Construction (Submersible)
- ▶ Microprocessor Accuracy
- ▶ LED Indication
- ▶ CSA / NRTL Class II Div 1 Groups E, F & G Approved
- ▶ IP67 Protection

PART NUMBERS/ACCESSORIES

- | | |
|--------------|---------------------------------------|
| ▶ M3001V10F | M300 Slipswitch (2 Wire) |
| ▶ M3005V10CA | M300 Slipswitch (5 Wire) |
| ▶ A34NPT | 3/4" NPT Conduit Adapter |
| ▶ WG1-4B-4 | Whirligig® Shaft Sensor Mount |
| ▶ MAG2000 | Mag-Con™ Whirligig Magnetic Connector |
| ▶ SM2 | SpeedMaster™ Sensor Testing Device |
| ▶ CDL1 | 2 Wire Load Device (110 VAC) |
| ▶ CDL4 | 2 Wire Load Device (24 VDC) |



The SpeedMaster™ is the only device that accurately tests the calibration of a speed switch, and allows testing of the alarm and shutdown features of the sensor while installed on the machine shaft.

To see it in action, visit:
www.go4b.com/speedmaster



ATEX and IECEx Versions Available

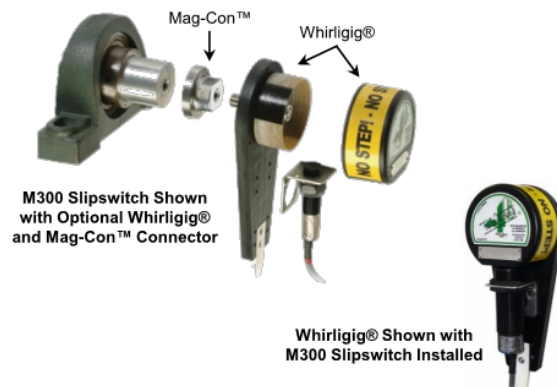

M300 Slipswitch Shown with Optional Whirligig® and Mag-Con™ Connector

Whirligig® Shown with M300 Slipswitch Installed

Please refer to instruction manual for correct installation.
Information subject to change or correction. Nov 2010

4B COMPONENTS LIMITED -

625 Erie Avenue, Morton, IL 61550 USA Tel: 309-698-5611 Fax: 309-698-5615

www.go4b.com/usa



M300 Slipswitch

BETTER BY DESIGN

DIMENSIONS

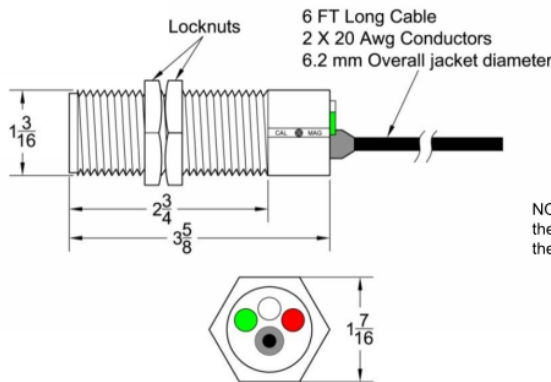

Dimensions in Inches Unless Noted

CONNECTIONS

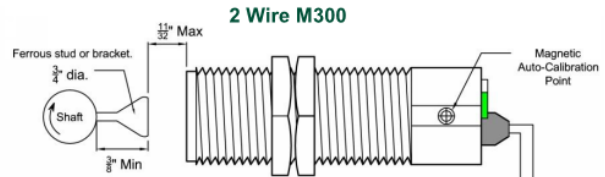

NOTE: The load must have the same voltage rating as the supply being used.

2 Wire M300

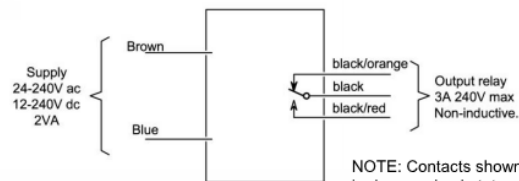

NOTE: Contacts shown in de-energized state

5 Wire M300

TECHNICAL SPECIFICATIONS

M300 Slipswitch - Monitors Rotating Machinery for Dangerous Underspeed Conditions

	M3001V10F (2 Wire)	M3005V10CA (5 Wire)
Power Supply:	24-240 VAC/VDC	12-240 VDC / 24-240 VAC
Power Consumption:	Load dependent (200 mA maximum)	30 mA
Fuse:	5 amp maximum	5 amp maximum
Output:	Triac, normally closed above set speed, normally open at 20% below set speed	Relay, normally energized, closed contact above set speed. Normally de-energized, open contact at 20% below set speed
Relative Humidity:	90% RH	90% RH
Switching Capacity:	200 mA maximum	N/A
Contact Rating:	NA	3 A - 240 VAC (non-inductive)
Saturation Voltage:	8 Volts maximum (output on)	N/A
Leakage Current:	1.6 mA maximum (output off)	N/A
Operating Temperature:	-13°F (-25°C) to +158°F (70°C)	5°F (-15°C) to +122°F (50°C)
Start Up Delay:	0 - 30 seconds (programmable)	0 - 30 seconds (programmable)
Sensing Range:	11/32" (9mm) maximum on ferrous metal	11/32" (9mm) maximum on ferrous metal
Input Pulse Range:	10 - 3,600 ppm	10 - 3,600 ppm
Trip Point:	20% below set speed	20% below set speed
LED Indicator:	Red LED indicates input pulses. Green LED shows output at nominal speed and acts as a calibration aid.	
Calibration:	Magnetic	Magnetic
Cable:	6' (2m) 2 conductor	6' (2m) 5 conductor
Approval:	CSA / NRTL Class II Div 1 Groups E, F, & G (US and Canada)	CSA / NRTL Class II Div 1 Groups E, F, & G (US and Canada)
Protection:	IP67	IP67

Please refer to instruction manual for correct installation. Information subject to change or correction. Nov 2010

4B Belt Alignment/Motion & Broken/Slack Chain Sensor

Rolfes Belt Alignment Indicator

**INSTALLATION
AND
INSTRUCTION MANUAL

FOR**



**TM-16 EMERGENCY
WARNING
SYSTEM**

SPECIAL NOTE BOONE CABLE WORKS & ELECTRONICS, INC.
1773-219TH LANE – P.O. BOX 429
READ THIS ENTIRE BOOKLET BOONE, IOWA 50036 USA
BEFORE PROCEEDING WITH PHONE (515) 432-2010 FAX (515) 432-5262
THE INSTALLATION TOLL FREE NUMBER – 1-800-265-2010
Web Address: (rolfesatboone.com)

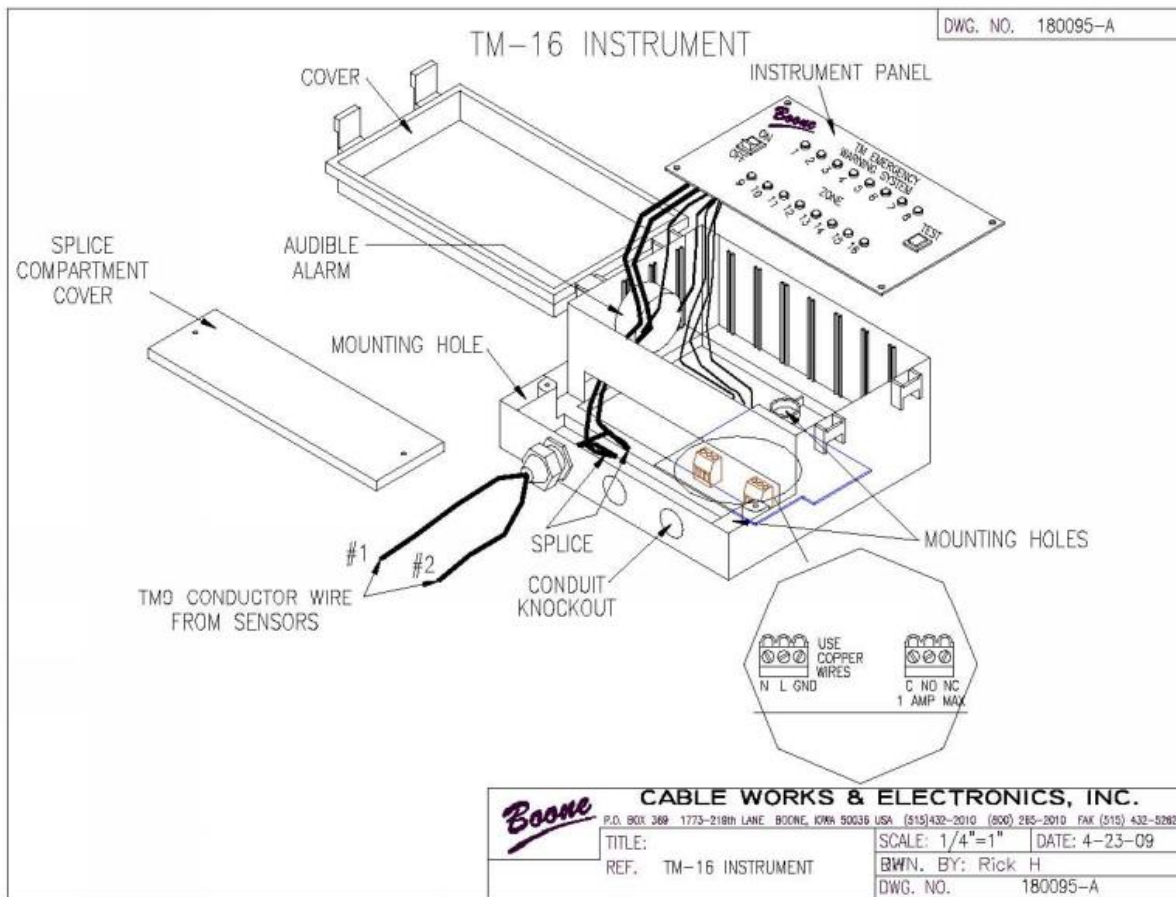

1. Wiring Runs, Color Coded and Splices

The Instrument, which can monitor 16 sensors, has two TM wires in its splice compartment. The wire marked #1 is for zones 1 through 8. The wire marked #2 is for zones 9 through 16.

The wire is run from the instrument to within 5 feet of each sensor. Strap and mount the wire so that it is exposed to the least amount of physical and environmental stress. The most desirable method is to enclose all wires in a dedicated conduit to provide mechanical protection.

“WARNING – IF THE SENSOR IS NOT ATTACHED PROPERLY AND SECURELY TO THE MONITORED PIECE OF EQUIPMENT, HEAT MAY FAIL TO TRANSFER TO THE SENSOR CAUSING IT TO NOT OPERATE PROPERLY. CHECK THE SENSORS REGULARLY TO SEE IF THEY ARE ATTACHED SECURELY.”

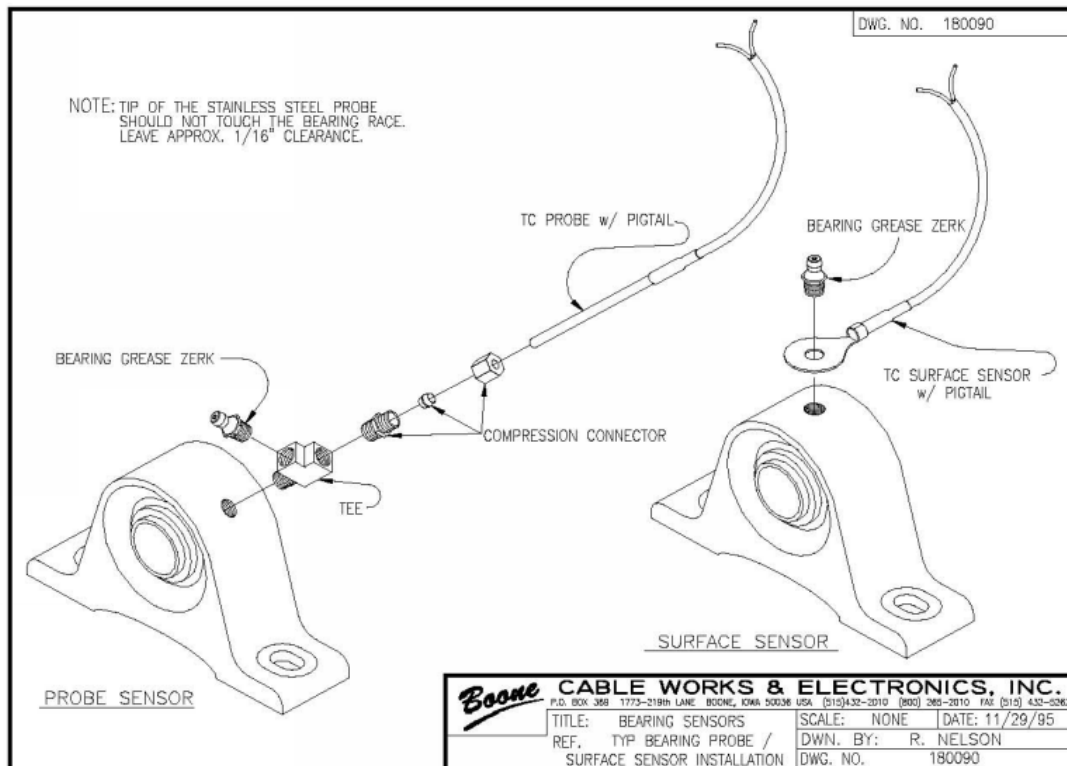

□. **Belt Alignment**

Belt alignment is accomplished by attaching the sensor to a brass heat transfer plate (See Drawing #180091 and 180091-A for conduit ready installations). The brass pad transfers the heat of the belt rubbing against it and activates the sensor. Two style of brass plates are available, as ½ moon and an optional round disk style. The ½ moon offers a greater range of motion on the belt, while the round disk is easier to install. It is important to tighten the sensor securely for a good thermal bond.

The sensor has a thermostat attached to the housing with approximately 10 feet of wire. See Drawing #180096-A when wiring the probe into the system.

“WARNING – IF THE SENSOR IS NOT ATTACHED SECURELY TO THE MONITORED PIECE OF EQUIPMENT, HEAT MAY FAIL TO TRANSFER TO THE SENSOR CAUSING IT TO NOT OPERATE PROPERLY. CHECK THE SENOSRS REGULARLY TO SEE IF THEY ARE ATTACHED SECURELY.”

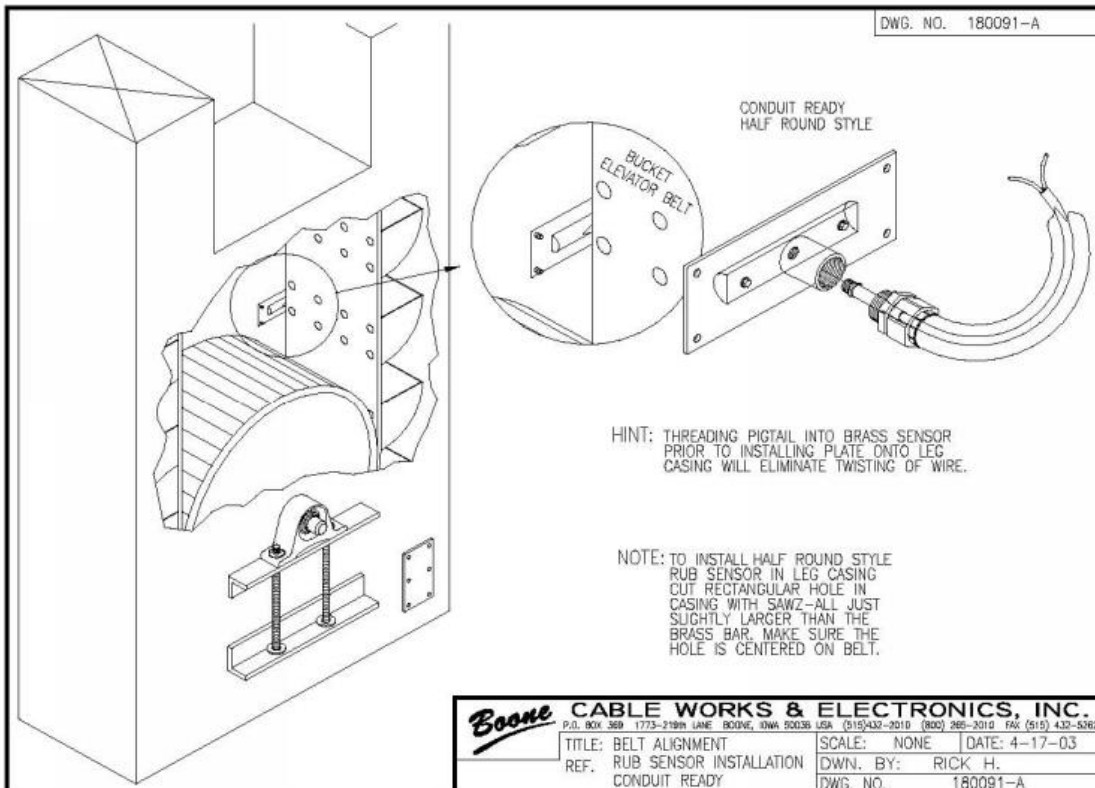
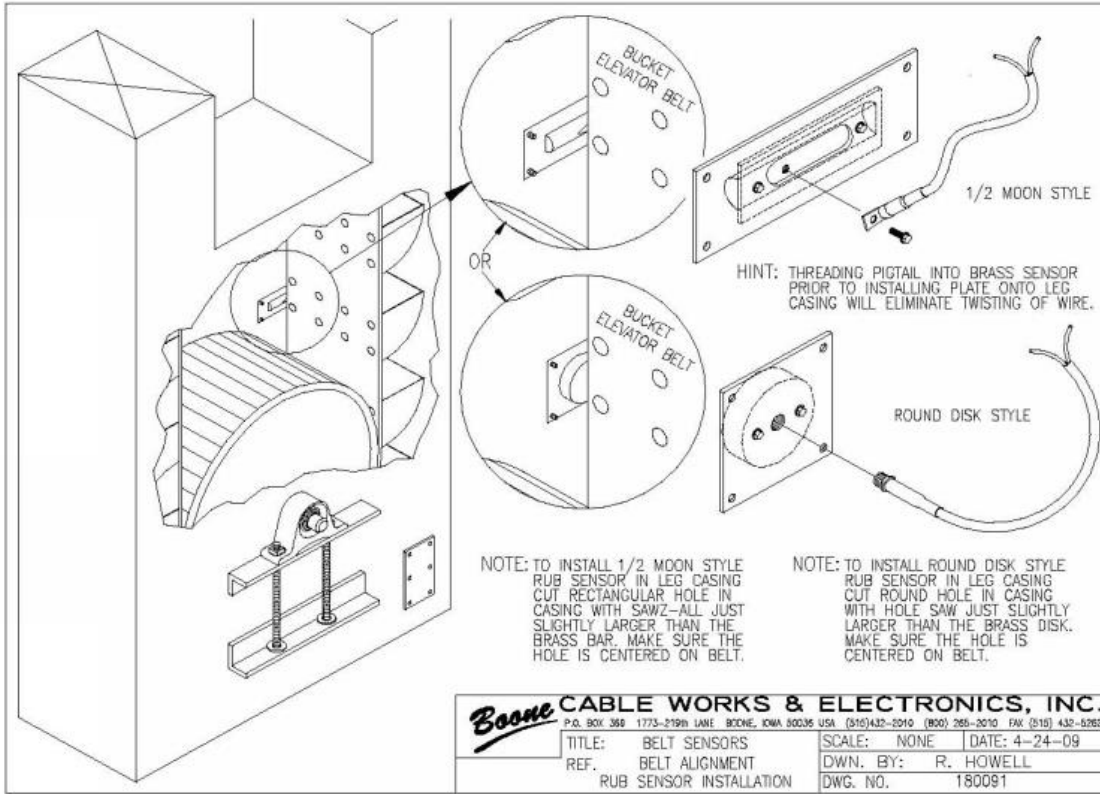

Omron Limit Switch

General-purpose Limit Switch

D4A-□□□N

CSM_D4A-_N_DS_E_4_2

The Limit Switch with Better Seal, Shock Resistance, and Strength

- A double seal on the head, a complete gasket cover, and other features ensure a better seal (meets UL NEMA 3, 4, 4X, 6P, 12, 13).
- Wide standard operating temperature range: -40°C to +100°C (standard type).
- Models with fluoro-rubber available for greater resistance to chemicals.
- Block mounting method also reduces downtime for maintenance.
- DPDT, double-break models available for complex operations.
- Approved by UL, CSA, and CCC (Chinese standard). (Ask your OMRON representative for information on approved model.)



For the most recent information on models that have been certified for safety standards, refer to your OMRON website.

⚠ Be sure to read *Safety Precautions* on page 14 to 15 and *Safety Precautions for All Limit Switches*.

Model Number Structure

Model Number Legend (Not all combinations are possible. Ask your OMRON representative for details.)

D4A-□□□□N (Set model number)
(1)(2) (3)

(1) Receptacle box

- 1 : 1/2-14 NPT conduit (SPDT, double-break)
- 2 : 1/2-14 NPT conduit (DPDT, double-break)
- 3 : G 1/2 conduit (SPDT, double-break)
- 4 : G 1/2 conduit (DPDT, double-break)

(2) Switch Box

- 1 : SPDT, double-break, without indicator
- 3 : SPDT, double-break, neon lamp
- E : SPDT, double-break, LED (24 VDC, leakage current: 1.3 mA)
- 5 : DPDT, double-break, simultaneous operation, without indicator
- 7 : DPDT, double-break, sequential operation, without indicator *1
- 9 : DPDT, double-break, center neutral operation, without indicator *2
- L : DPDT, double-break, simultaneous operation, neon lamp
- P : DPDT, double-break, simultaneous operation, LED

(3) Head

- 01 : Roller lever, standard
- 02 : Roller lever, high-sensitivity
- 03 : Roller lever, low torque
- 04 : Roller lever, high-sensitivity, low torque
- 05 : Roller lever, maintained
- 17 : Roller lever, sequential operation
- 18 : Roller lever, center neutral operation
- 06 : Side plunger, standard
- 07-V : Side plunger, vertical roller
- 07-H : Side plunger, horizontal roller
- 08 : Side plunger, adjustable
- 09 : Top plunger, standard
- 10 : Top plunger, roller
- 11 : Top plunger, adjustable
- 12 : Flexible rod, spring wire
- 14 : Flexible rod, plastic rod
- 15 : Flexible rod, cat whisker
- 16 : Flexible rod, coil spring

*1. Use the D4A-0017N Special Head.

*2. Use the D4A-0018N Special Head.

Note: Fluoro-rubber sealed type is also available.

D4A-□N

Approved Standard Ratings

UL/CSA

A600

D4A-□1□□N (SPDT, Double-break, Without Indicator)

Rated voltage	Carry current	Current (A)		Volt-amperes (VA)	
		Make	Break	Make	Break
120 VAC	10 A	60	6	7,200	720
240 VAC		30	3		
480 VAC		15	1.5		
600 VAC		12	1.2		

A300

D4A-□3□□N (SPDT, Double-break, With Neon Lamp)

Rated voltage	Carry current	Current (A)		Volt-amperes (VA)	
		Make	Break	Make	Break
120 VAC	10 A	60	6	7,200	720
240 VAC		30	3		

B600

D4A-□5□□N (DPDT, Double-break, Simultaneous Operation)

D4A-□7□□N (DPDT, Double-break, Sequential Operation)

D4A-□9□□N (DPDT, Double-break, Center Neutral Operation)

Rated voltage	Carry current	Current (A)		Volt-amperes (VA)	
		Make	Break	Make	Break
120 VAC	5 A	30	3	3,600	360
240 VAC		15	1.5		
480 VAC		7.5	0.75		
600 VAC		6.0	0.6		

CCC (GB14048.5)

Applicable category and ratings
AC-15 2 A/125 VAC

Characteristics

Degree of protection (reference standards)		IP67 and NEMA 1, 2, 3, 4X, 5, 6P, 12, and 13
Durability *2	Mechanical: *1	SPDT, double-break, roller lever: 50,000,000 operations min. DPDT, double-break, roller lever: 30,000,000 operations min.
	Electrical:	SPDT, double-break: for 125 VAC, 10 A resistive load: 1,000,000 operations min. DPDT, double-break: for 125 VAC, 5 A resistive load: 750,000 operations min.
Operating speed		1 mm/s to 2 m/s (in case of D4A-3101N roller lever model)
Operating frequency	Mechanical:	300 operations/minute
	Electrical:	30 operations/minute
Rated frequency		50/60 Hz
Insulation resistance		100 MΩ min. (at 500 VDC) between terminals of the same polarity, between current-carrying metal parts and ground, and between each terminal and non-current-carrying metal part
Contact resistance		25 mΩ max. (initial value)
Temperature rise		50°C max.
Dielectric strength	Between terminals of same polarity	1,000 VAC, 50/60 Hz for 1 min.
	Between current-carrying metal parts and ground	2,200 VAC, 50/60 Hz for 1 min. *3
	Between each terminal and non-current-carrying metal part	2,200 VAC, 50/60 Hz for 1 min. *3
Pollution degree (operating environment)		3
Protection against electric shock		Class I (with grounding terminal)
Vibration resistance	Malfunction: *4	10 to 55 Hz, 1.5-mm double amplitude
	Destruction:	1,000 m/s ² max.
Shock resistance	Malfunction: *4	SPDT, double-break, roller lever: 600 m/s ² max. DPDT, double-break, roller lever: 300 m/s ² max.
Ambient operating humidity		35% to 95%RH (with no icing)
Weight		Approx. 290 g (in case of D4A-3101N)

Note: The above figures are initial values.

*1. Excluding maintained models.

*2. The values are calculated at an operating temperature of +5°C to +35°C, and an operating humidity of 40% to 70%RH. Contact your OMRON sales representative for more detailed information on other operating environments.

*3. 1,500 VAC is applied to the indicator lamp type.

*4. Not including Flexible rods (cat whisker, plastic rod, coil spring, and spring wire types).

Item	Type	Roller lever *1	Plunger, flexible rod *2	With indicator
Ambient temperature		-40°C to +100°C	-20°C to +100°C	-10°C to +80°C

*1. Excluding low-torque and high-sensitivity models.

*2. Including roller lever low-torque and high-sensitivity operating models.

D4A-□N

**Contact Forms (Switch Boxes)
STDP Double-break Switches**

Type	Contact model			Operating pattern
	Without indicator	With neon lamp indicator *	With LED indicator *	
1NC/1NO snap-action	D4A-0100N 	D4A-0300N 	D4A-0E00N 	
		Lamp Unit Internal Circuits 	Lamp Unit Internal Circuits 	

* Switches with indicators are factory-set to light when the switch is not operated.

DTDP Double-break Switches

Each of these Switches can be used to replace two limit switches in applications, such as high-speed control in machine tools and switching motors between forward and reverse, that previously required 2 limit switches. This simplifies wiring, saves space, and reduces costs.

Type	Contact model			Operating pattern	Remarks
	Without indicator	With neon lamp indicator *	With LED indicator *		
2NC/2NO snap-action, simultaneous operation	D4A-0500N	D4A-0L00N	D4A-0P00N		Head is compatible with double-break head. Can be switched for operation on both sides of actuator.
2NC/2NO snap-action, sequential operation (2-step operation)	D4A-0700N	---	---		Use the D4A-0017N Special Head.
2NC/2NO snap-action, central neutral operation	D4A-0900N	---	---		Use the D4A-0018N Special Head.

Item	Without indicator	With neon lamp indicator *		With LED indicator *	
		D4A-0L00N		D4A-0P00N	
Contact form					
Lamp unit internal circuit	---				

* Switches with indicators are factory-set to light when the switch is not operated, but the setting can be changed to light for operation (dotted lines).

D4A-□N

Head and Lever Positions

- The operating head can be positioned and locked in any of four 90° positions and a lever can lock in any position through 360° around the shaft of the Limit Switch. Furthermore, the lever can be reversed and attached to the shaft (refer to the figures below on the right hand side). Therefore the roller is compatible with a wide movement range of a dog.
- A Fork Lever Lock can be used with maintained models (D4A-0005N) only.

Remove the head from the Switch by loosening the screws (the screws can be loosened but not removed from the head).

The operating head can be positioned and locked in any of four 90° positions.

The lever can lock in any position through 360° around the shaft. The lever can be reversed and attached to the shaft, in which case the switching operation should complete in a range of 0° to 180°.

Four, M4 x 12

180° operating position

360° operating position

There are four kinds of fork lever locks. The position of each roller is different. It is possible to use D4A-E00 through D4A-E30 levers instead, if they are reversed before attaching. They can be used with D4A-□05N models only.

D4A-E00 D4A-E10

D4A-E20 D4A-E30

By loosening the Allen-head bolt on an adjustable roller lever or rod lever, the length of the lever can be adjusted.

D4A-C00 D4A-D00

D4A-D00 Loosen the bolt to adjust the length of the lever. Adjustable between 33 and 91 mm.

Loosen the screw to adjust the length of the rod.

Lever Position

D4A-A00: 59 to 64.5, 52.9 to 58.4

D4A-A10: 67 to 72.5, 44.9 to 50.4

D4A-A20: 73 to 78.5, 38.9 to 44.4

D4A-A30: 86.9 to 92.4, 25 to 30.5

Nameplate

OMRON 1U

D4A- ← The whole switch model without lever is printed.

NEMA A600

TYPE 3, 4, 4X, 6P and 13

IND. CONT. CO.

LISTED

782Y

MUST BE SAME POLARITY

2A 125VAC

SWITCH BODY ONLY

D4A-0100N ← The type of switch box is printed. (The type is also indicated on the head and receptacle.)

MADE IN JAPAN

When ordering, do not confuse set model numbers and model numbers for individual blocks.

Compatibility with D4A-□

The D4A-□N is compatible with the D4A-□ when the following accessories are attached to the D4A-□N.

D4A-□ Receptacle box + D4A-□N Switch box + D4A-□N Head

The D4A-□N without the above accessories is not compatible with the D4A-□.

Tsubaki Shock Relay



EHFSS05.0601-9

SHOCK RELAY

TSBSS Series

INSTRUCTION MANUAL



WARNING

1. Make sure you read this instruction manual thoroughly before installing, wiring, operation and inspecting this SHOCK RELAY.
2. Please make sure that this instruction manual accompanies the SHOCK RELAY to the end user.
3. Product specification are subject to change for improvement without notice.
4. Disconnect power. Always lock out power switch before installing, removing, or servicing unit. Comply with Occupational Safety and Health Standards 1910. 147 "The Control of Hazardous Energy (Lock Out/Tag Out)."
5. Install in proper enclosure in accordance with NEMA 250-1991 "Enclosures for Electrical Equipment (1000Volts Maximum)" and NFPA496 1993 edition "Purged and Pressurized Enclosures for Electrical Equipment, 1993 Edition." When revisions of these standards are published, the updated edition shall apply.
6. Guards must be provided on all power transmission and conveyor applications in accordance with provisions of ASME B15.1-1996 "Safety Standards for Conveyors and Related Equipment, or other applicable standards. When revision of these standards are published, the updated edition shall apply.



CAUTION

- If danger is expected from your application, take the necessary steps to ensure that it operates safely.
- If your Tsubaki Emerson product does not operate normally, take care to ensure that dangerous operating conditions do not occur.
- Wear suitable clothing and protective equipment (safety glasses, gloves, safety shoes, etc.)
- Keep your work place tidy and safe to prevent accidents.

TSUBAKI E & M CO.

2013.12.1

4. Specifications

Series		TSB SS	
Current Setting * ¹	Model	Range	
	05	0.5-6A	
	30	3-30A	
	60	5-60A	
Time Setting * ¹	Starting Trip Delay	Start Time	0.2-30s
	Trip Time	Shock Time	0.2-10s
Accuracy		Current	±10% (Full scale)
Control Power Supply		100~240VAC ± 10%, 50/60Hz	
Maximum motor voltage		600VAC, 50/60Hz * ²	
Current Sensing method		2 Integral Current Transformer	
Output Relay	Mode	1-SPDT(1c)	
	Contact Rating (max.)	3A / 240VAC cos φ =1	
	Contact Rating (min.) * ³	10VDC 10mA	
	Operation	Fail safe operation, Normally energized	
	Reset	Manual or Electrical (Interrupt power supply)	
	Expected Life	100,000 operations	
Ambient Environment	Temperature	Operating	-20 - +60°C (-4 - +158 F)
		Storage	-30 - +70°C (-22 - +176 F)
	Humidity	45 – 85% RH without Condensation	
	Altitude	2,000m max.	
	Pollution degree	Class 3 To be free from dust and corrosive gas	
Vibration	5.9 m/s ² or less.		
Insulation	Between casing and circuit	Over 10MΩ with 500 VDC Megger	
Dielectric Strength	Between casing and circuit	AC 2000V, 60Hz, 1min	
	Between contacts	AC 1000V, 60Hz, 1min	
	Between circuits and contacts	AC 2000V, 60Hz, 1min	
Protection Structure		IP20	
Power Consumption	115VAC	2.7 VA(0.35W)	
	230VAC	11.0 VA(1.2W)	
Material	Case	Polyamide 66 (PA66)	
	Terminal cover	Polyamide 6 (PA6)	
Mounting		35mm DIN rail or Panel	
Dimension(W x H x D /Including Integral CT Windows)		54 x 72 x 64.5 mm	
Weight		Less than 200g (0.44LBS) without External CT	

*1 Current and time setting ranges can be set within the warranty range, but not the upper or lower level of setting volume.

*2 When Shock Relay is used with Inverter, the output frequency of Inverter should be from 30Hz to 60Hz.

*3 When directly inputting output relay contact into the programmable controller (PLC), be aware that a minute electric current can cause contact failure. As for the input to PLC, it is commended to drive the relay coil for minute current by relay signal of Shock Relay at first, then input this relay contact to PLC.

*4 CE marking

EMC Directive 03.05.1989 Low Voltage Directive 19.02.1973

EN60947-1 2001 EN50081-2 1993 EN55011 1991

EN50082-2 1995 EN61000-4-2 2002 (□4kV)

5. Installation

1. Environmental specifications

Install the Shock Relay in the following environment.

- Temperature: -20 to +60°C not in direct sunlight.
- Humidity: 45~85% relative humidity without condensation and freezing.
- Place: Indoors, no water splash.
- Atmosphere: Free from dust, corrosion gas, and oil mist.
- Height: 2000m or less above sea level.
- Vibration: 5.9m/s² and under.

2. Installation to the panel

Put the Attachment for installation at the both side or Shock Relay, and install Shock Relay to the panel

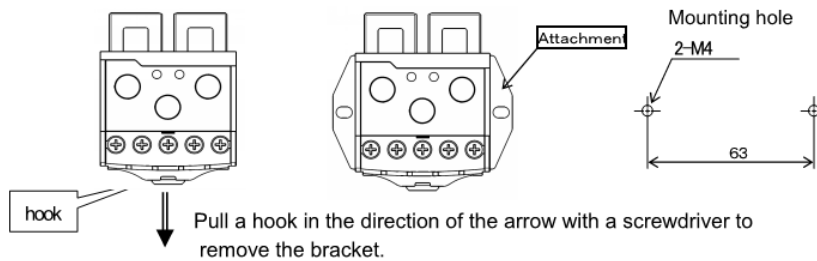

3. Installation to the DIN rail

While pulling the hook of Shock Relay to the arrow direction, install Shock Relay to 35mm DIN rail. When removal, put the hook to the arrow direction with flathead screwdriver.

6. Wiring

- (1) Connect 100-240VAC power source to the terminal L1- L2.

Never connect the output of an inverter or a servo driver to terminals L1-L2.

Install an insulation transformer between the power line and terminals L1-L2 of the SHOCK RELAY when harmonic noise is included in the power line.

- (2) Check and correct the following items before turning the power on.

- Is there any misconnection?
- Have you forgotten to complete any connections?
- Are there any abnormal conditions such as a short-circuit or ground fault?

	WARNING	ELECTRICAL SHOCK AND BURN Do not operate without the ground wire connected.
--	----------------	---

7. Terminal Function

Terminal	Function	Contents.
L1	Power Supply	100 - 240VAC commercial power supply is wired
L2		
95	Output Relay	Common
96		Normally close (Power on : open Power off or tripped: close)
98		Normally open (Power on : close Power off or tripped: open)

8. Current Transformer

Select the number of wires passing through the CT (Current Transformer) by using the following table for best performance. When two motor leads pass through the CT, the current sensed by the CT is twice the motor current flowing through the motor lead.

AC 200 ~ 230 Volt Motor				AC 400 ~ 460 Volt Motor			
Motor Capacity (kW)	Motor Capacity (Hp)	TSBSS TYPE	Wires passing through CT	Motor Capacity (kW)	Motor Capacity (Hp)	TSBSS TYPE	Wires passing through CT
0.1	1/8	TSBSS05	4	—	—	—	—
0.2	1/4	TSBSS05	3	0.2	1/4	TSBSS05	4
0.4	1/2	TSBSS05	2	0.4	1/2	TSBSS05	3
0.75	1	TSBSS05	1	0.75	1	TSBSS05	2
1.5	2	TSBSS30	3	1.5	2	TSBSS05	1
2.2	3	TSBSS30	2	2.2	3	TSBSS05	1
3.7	5	TSBSS30	1	3.7	5	TSBSS30	3
5.5	7-1/2	TSBSS30	1	5.5	7-1/2	TSBSS30	2
7.5	10	TSBSS60	1	7.5	10	TSBSS30	1
11	15	TSBSS60	1	11	15	TSBSS30	1
—	—	—	—	15	20	TSBSS60	1
—	—	—	—	18.5	25	TSBSS60	1
—	—	—	—	22	30	TSBSS60	1

Basic wiring diagram

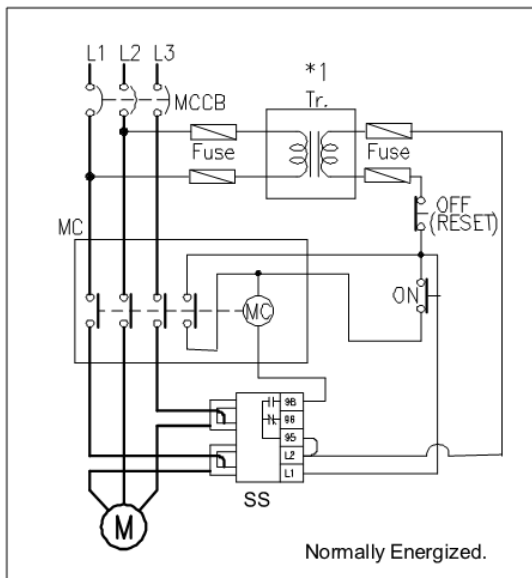

M : THREE-PHASE MOTOR

MC : Magnetic contactor

ON : Start switch

OFF : Stop switch

Fuse : Fuse

Tr : Transformer

1. A transformer may be required, depending on the voltage of Motor (i.e. over 240VAC)
2. Output relay is normally energized when there is power to the Shock Relay. When Shock Relay trips, the contacts change state.
3. Two of three phases of the motor are passed through the Shock Relay's CT in the same direction.
4. A fire might be happened as there is no protection circuit in main circuit.
5. Please select a fuse capacity depending upon capacity of a contactor MC to be connected.

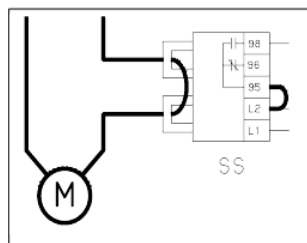

M: SINGLE-PHASE MOTOR

9. TSB2CT (External 2-phase CT)

• Specifications

Model No.	TSB2CT100	TSB2CT200	TSB2CT300
Class	3		
Rated primary current	100A	200A	300A
Rated secondary current	5A		
Rated burden	5VA		
Rated frequency	50/60Hz		
Approximately weight	0.5kg		

• Installation

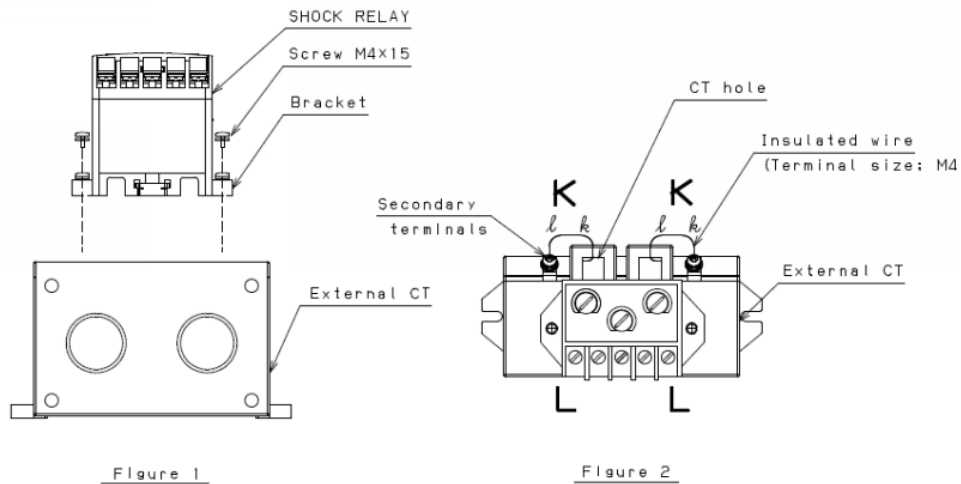

Procedure

1. Install the SHOCK RELAY on the External CT with screws according to Figure 1.
2. Connect the wire between "k" and "λ" after passing the wire through CT hole According to Figure 2.

10. Construction

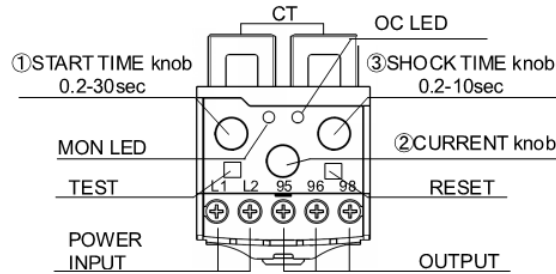

Description

Shock Relay senses the motor current passing through the two CTs and automatically detects the starting of the motor.

Shock Relay filters out the large starting current during the start-up delay preset with the START TIME knob.

Shock Relay detects an overload by comparing the CT-sensed motor current with the trip current that is preset with the CURRENT knob.

When the motor current exceeds the preset trip current level, the Shock Relay trips after the trip delay that is preset with the SHOCK TIME knob.

Shock Relay can be used as an electronic shear-pin for a motor-driven machine.

Every time that the Shock Relay trips, always investigate the cause of the overload and correct the cause.

Release the tripped Shock Relay by pressing the RESET button or by shutting power down before restarting the equipment.

As a fail-safe, the Shock Relay keeps the built-in output relay operating except when trips occur, provided that power is applied to the Shock Relay.

Shock Relay lights the OC LED when sensing a greater current than preset with the CURRENT knob and remains lit after the relay trips. MON LED (green) shows monitor condition. It is turned on under the normal monitor condition, and the relay turns off the lights while it is outputted.

Shock Relay provides a TEST button to confirm the operation of the output relay and the two timers – START TIME and SHOCK TIME. The Shock Relay trips after the total of the START TIME and the SHOCK TIME when the TEST button is pressed and held.

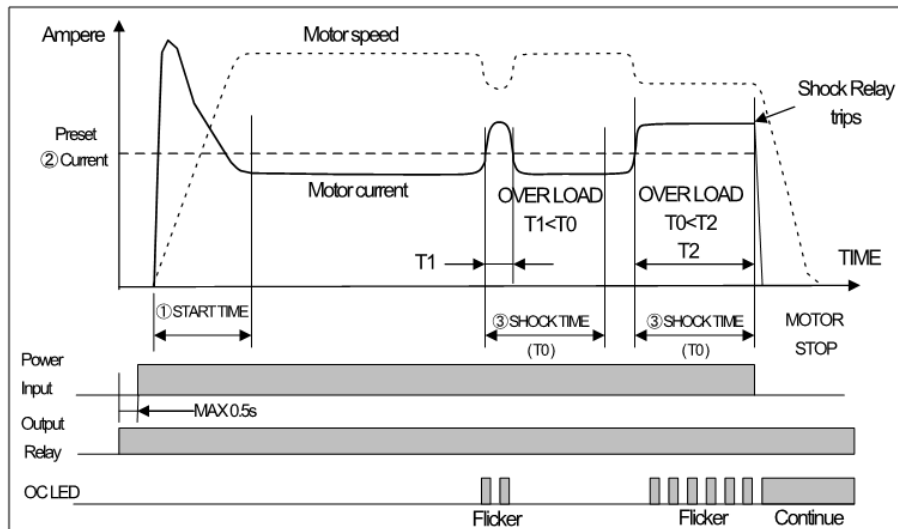

11. Set up

1. Set START TIME knob (start-up delay) at the start-up time if the start-up time is known. Set START TIME knob (start-up delay) at the maximum if the start-up time is unknown.
2. Set SHOCK TIME knob (trip delay timer) at the desired trip time.
3. Set CURRENT knob (trip current) at the rated current of the motor.
4. Supply control voltage to the Shock Relay. Then confirm that the SHOCK TIME activates its built-in output relay – the contacts will change state.
5. Press and hold the TEST button. Confirm that the Shock Relay lights its OC LED and trips after total of the START TIME and SHOCK TIME. Confirm that this also deactivates the built-in output relay.
6. Press the RESET button. Confirm that the OC LED turns off and that the built-in output relay activates.
7. Start the motor and check that the start-up time was correctly set. Then slowly turn the CURRENT knob counter clockwise until the Shock Relay flashes its LED. At this point, the CURRENT knob indicates 100% of the motor running current.
8. Set the CURRENT knob at the proper trip current, this is commonly at 110% of the actual motor running current.
9. Recheck and adjust the START TIME knob so that it is a little longer than the normal start-up time.

12. Troubleshooting

Trouble	Check	Result	Solution
Even when the Shock Relay trips, the 95-98 contacts do not shut down the attached motor.	Wiring of the power source (L1-L2)	Not attached correctly	Wire properly.
	Power source voltage (L1-L2) by voltage tester	Out of source voltage	Supply 100-240V AC voltage
The Shock Relay does not trip even with the CURRENT knob set to the minimum	Model no. of the SHOCK RELAY See the nameplate	Incorrect size Shock Relay	Switch to the correct Shock Relay
	Number of wires passing through the CT	Improper	Rewire properly
	Press and hold TEST button	It does not trip	Exchange SHOCK RELAY for a new one
During start-up, an overload trip occurs.	CURRENT knob setting	Set too low	Turn CURRENT knob CW and set it properly
	START TIME knob setting	Set too short.	Turn START TIME knob CW and set it properly
During operation, overload trip occurs.	CURRENT knob setting	Set too low	Turn CURRENT knob CW and set it properly
	SHOCK TIME knob setting	Set too short.	Turn SHOCK TIME knob CW and set it properly
Shock Relay does not trip with an overload occurs	CURRENT knob setting	Set too high	Turn CURRENT knob CCW and set it properly
	SHOCK TIME knob setting	Set too long	Turn SHOCK TIME knob CCW and set it properly
	Press and hold TEST button	It does not trip	Exchange SHOCK RELAY for new one

If replacement of the shock Relay is necessary, please make contact with our company office.

13. Maintenance

- (1) To prevent an accident, keep the surrounding area clean and create a safe environment.
- (2) Before checking the installation and connection of the Shock Relay, turn off the power source. Be sure that the equipment is completely stopped and the OC LED of the Shock Relay is off. Make sure that the power source is locked out and cannot be accidentally turned on.

14. Daily check and periodic check

- (1) Confirm that there is no looseness in the installation of the Shock Relay and current transformer. Check the wiring connections every six months.
- (2) Regularly check the function of the output relay, terminal 95-96, terminal 97-98, by pressing the TEST button.
- (3) A typical life time of electrolytic capacitor mounted in the SHOCK RELAY is about 10 years at an average ambient temperature of 30°C, but this lifetime may vary with a different ambient environment and with the operating period when power is supplied. We recommend you to exchange the Shock Relay for a new one before trouble occurs.

15. Point for safe use

- (1) Take measures beforehand to prevent danger when using a TSUBAKI product.
- (2) If our product begins to operate improperly, be sure to take measures to prevent a dangerous situation from arising.

16. Warranty

1 . Range of warranty

With regard to any troubles happened to our products, replacement or repair of such troubled parts will be provided for free of charge during the effective period of warranty, provided that installation and maintenance/management of said products have been performed properly pursuant to the description of this instruction manual and said products have been used under the condition described in the brochures or agreed separately through mutual consultations. The content of warranty is limited only to the Shock Relay itself delivered to you and the judgment thereof will be made by our selection because such judgment pertaining to the range of warranty is often complex.

2 . Warranty period

The warranty period shall be either 18 months after shipment from our factory or 12 months after starting operation, whichever is shorter. Any and all inspection/repair undertaken by us after the above warranty period has passed will be charged. Should questions arise, please do not hesitate to contact us or the dealer from whom you purchased.

3 . Miscellaneous

- (1) Any matters described in this instruction manual are subject to change without notice.
- (2) We have tried our best in preparing the contents of this instruction manual. Should any mistake or oversight be found, we will be more than happy if you would advise us of them.



Should you have any questions concerning assembly instructions, parts or drawings, please feel free to contact us at any of the following.

© Chief Industries, Inc. Inc.
4400 East 39th Street • PO Box 848
Kearney, NE 68847
Phone 800.359.7600

For more information about Chief Industries, Inc. and additional products or services visit our website
www.agri.Chiefind.com